
SimplIQ_{Line}

Bassoon **Digital Servo Drive** **Installation Guide**



October 2015 (Ver. 1.600)



www.elmomc.com

Notice

This guide is delivered subject to the following conditions and restrictions:

- This guide contains proprietary information belonging to Elmo Motion Control Ltd. Such information is supplied solely for the purpose of assisting users of the Bassoon servo drive in its installation.
- The text and graphics included in this manual are for the purpose of illustration and reference only. The specifications on which they are based are subject to change without notice.
- Elmo Motion Control and the Elmo Motion Control logo are trademarks of Elmo Motion Control Ltd.
- Information in this document is subject to change without notice.

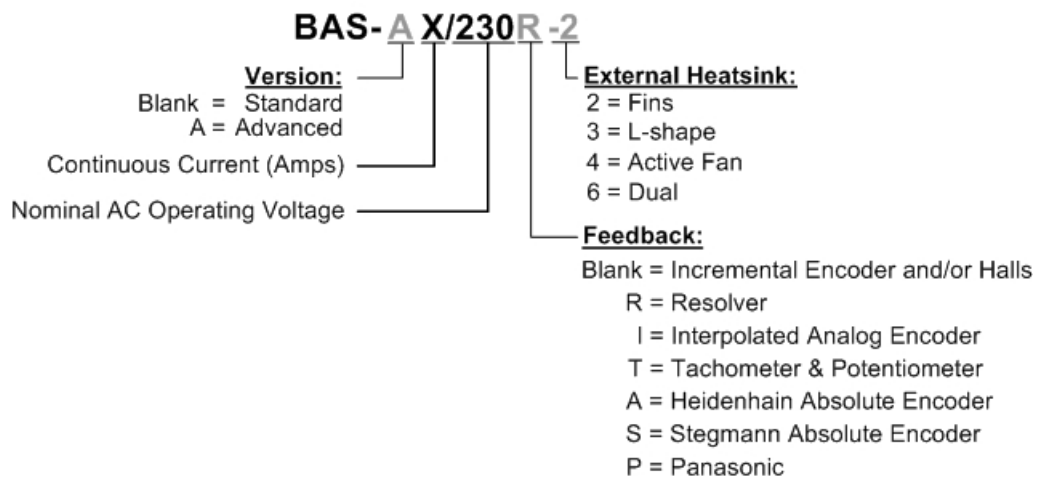
Document no. MAN-BASIG (Ver. 1.600)

Copyright © 2015

Elmo Motion Control Ltd.

All rights reserved.

Catalog Number



Cable Kit

- Catalog number: HAR-CABLEKIT (can be ordered separately)
- For further details, see the documentation for this cable kit ([MAN-CBLKIT.pdf](#)).

Revision History

Version	Date	Release
Ver. 1.0		Initial release
Ver. 1.3	Apr 2008	Updated Power Ratings Table in Section 4.2
Ver. 1.4	Aug 2008	Added Section 3.5.6.4: Differential Pulse-and-Direction Input
Ver. 1.5	Dec 2011	Formatted according to new template and new drawing with fan added
Ver. 1.501	Feb 2013	Added a caution and recommendation on the type of cleaning solution to use for the Elmo unit.
Ver. 1.502	July 2014	General format updates
Ver. 1.503	Oct 2014	Correction to Power Ratings Table in Section 4.2
Ver. 1.600	Oct 2015	Addition of new versions 9/230 and 6/230-18P

Elmo Worldwide

Head Office

Elmo Motion Control Ltd.

60 Amal St., POB 3078, Petach Tikva 49516

Israel

Tel: +972 (3) 929-2300 • Fax: +972 (3) 929-2322 • info-il@elmomc.com

North America

Elmo Motion Control Inc.

42 Technology Way, Nashua, NH 03060

USA

Tel: +1 (603) 821-9979 • Fax: +1 (603) 821-9943 • info-us@elmomc.com

Europe

Elmo Motion Control GmbH

Hermann-Schwer-Strasse 3, 78048 VS-Villingen

Germany

Tel: +49 (0) 7721-944 7120 • Fax: +49 (0) 7721-944 7130 • info-de@elmomc.com

China

Elmo Motion Control Technology (Shanghai) Co. Ltd.

Room 1414, Huawen Plaza, No. 999 Zhongshan West Road, Shanghai (200051)

China

Tel: +86-21-32516651 • Fax: +86-21-32516652 • info-asia@elmomc.com

Asia Pacific

Elmo Motion Control APAC Ltd.

B-601 Pangyo Innovalley, 621 Sampyeong-dong, Bundang-gu, Seongnam-si, Gyeonggi-do,
South Korea (463-400)

Tel: +82-31-698-2010 • Fax: +82-31-801-8078 • info-asia@elmomc.com

Table of Contents

Chapter 1: Safety Information	8
1.1. Warnings	9
1.2. Cautions	9
1.3. Directives and Standards	10
1.4. CE Marking Conformance	10
1.5. Warranty Information	10
Chapter 2: Introduction	11
2.1. Drive Description	11
2.2. Product Features	11
2.2.1. Current Control	11
2.2.2. Velocity Control	11
2.2.3. Position Control	12
2.2.4. Advanced Position Control (<i>Advanced model only</i>)	12
2.2.5. Communication Options	12
2.2.6. Feedback Options	12
2.2.7. Fault Protection	13
2.3. System Architecture	13
2.4. How to Use this Guide	14
Chapter 3: Installation	15
3.1. Before You Begin	15
3.1.1. Site Requirements	15
3.1.2. Hardware Requirements	15
3.1.3. AC Power Requirements	17
3.2. Unpacking the Drive Components	17
3.3. Assembling the Heatsink	18
3.4. Mounting the Bassoon	18
3.4.1. Mounting on a DIN Rail	18
3.4.2. Mounting Directly onto a Wall	19
3.5. Connecting the Cables	20
3.5.1. Wiring the Bassoon	20
3.5.2. Connecting the Power Cables	23
3.5.2.1. Connecting the Motor Cable	23
3.5.2.2. Connecting the Main Power Cable	24
3.5.3. Connecting the Auxiliary Power Cable (J4)	25
3.5.4. Feedback and Control Cable Assemblies	26
3.5.5. Main Feedback Cable (Port J3)	27
3.5.6. Main and Auxiliary Feedback Combinations	34
3.5.6.1. Main Encoder Buffered Outputs or Emulated Encoder Outputs Option on Feedback B (J2) (YA[4]=4)	35

3.5.6.2.	Differential Auxiliary Encoder Input Option on Feedback B (J2) (YA[4]=2)	36
3.5.6.3.	Single-Ended Auxiliary Input Option on Feedback B (J2) (YA[4]=2)	37
3.5.6.4.	Pulse-and-Direction Input Option on FEEDBACK B (J2) (YA[4]=0).....	39
3.5.7.	I/O Cables	41
3.5.7.1.	Digital Input (Port J5)	41
3.5.7.2.	Digital Output (Port J6)	43
3.5.7.3.	Analog Input (Port J7)	44
3.5.8.	Communication Cable (Port J1, J8, J9).....	45
3.5.8.1.	RS-232 Communication	45
3.5.8.2.	CANopen Communication	46
3.6.	Powering Up	48
3.7.	Initializing the System.....	48
Chapter 4: Technical Specifications		49
4.1.	Features.....	49
4.1.1.	Motion Control Modes	49
4.1.2.	Advanced Positioning Motion Control Modes	49
4.1.3.	Advanced Filters and Gain Scheduling.....	49
4.1.4.	Fully Programmable.....	49
4.1.5.	Feedback Options	50
4.1.6.	Input/Output	50
4.1.7.	Built-In Protection	51
4.2.	Bassoon Dimensions.....	52
4.2.1.	Bassoon without a Fan	52
4.2.2.	Bassoon with a Fan	53
4.3.	Environmental Conditions	55
4.4.	Bassoon Connectors	56
4.4.1.	Connector Types	56
4.4.2.	Control and Feedback Connector Specifications.....	57
4.5.	Auxiliary Power Supply (J4)	58
4.6.	Control Specifications.....	58
4.6.1.	Current Loop.....	58
4.6.2.	Velocity Loop	59
4.6.3.	Position Loop	59
4.7.	Feedback.....	60
4.7.1.	Feedback Supply Voltage.....	60
4.7.2.	Incremental Encoder	60
4.7.3.	Digital Halls	61
4.7.4.	Interpolated Analog (Sine/Cosine) Encoder	61
4.7.5.	Resolver	62
4.7.6.	Tachometer.....	62
4.7.7.	Potentiometer	63
4.7.8.	Encoder Outputs.....	63



4.8.	I/Os	63
4.8.1.	Digital Input Interfaces	64
4.8.2.	Digital Output Interface	65
4.8.3.	Analog Input (J7).....	66
4.9.	Communications.....	66
4.10.	Pulse-Width Modulation (PWM).....	67
4.11.	Heat Sink Specifications.....	67
4.12.	Compliance with Standards.....	69

Chapter 1: Safety Information

In order to achieve the optimum, safe operation of the Bassoon servo drive, it is imperative that you implement the safety procedures included in this installation guide. This information is provided to protect you and to keep your work area safe when operating the Bassoon and accompanying equipment.

Please read this chapter carefully before you begin the installation process.

Before you start, ensure that all system components are connected to earth ground. Electrical safety is provided through a low-resistance earth connection.

Only qualified personnel may install, adjust, maintain and repair the servo drive. A qualified person has the knowledge and authorization to perform tasks such as transporting, assembling, installing, commissioning and operating motors.

The Bassoon servo drive contains electrostatic-sensitive components that can be damaged if handled incorrectly. To prevent any electrostatic damage, avoid contact with highly insulating materials, such as plastic film and synthetic fabrics. Place the product on a conductive surface and ground yourself in order to discharge any possible static electricity build-up.

To avoid any potential hazards that may cause severe personal injury or damage to the product during operation, keep all covers and cabinet doors shut.

The following safety symbols are used in this manual:



Warning:

This information is needed to avoid a safety hazard, which might cause bodily injury.



Caution:

This information is necessary for preventing damage to the product or to other equipment.



1.1. Warnings

- To avoid electric arcing and hazards to personnel and electrical contacts, never connect/disconnect the servo drive while the power source is on.
- Power cables can carry a high voltage, even when the motor is not in motion. Disconnect the Bassoon from all voltage sources before it is opened for servicing.
- The Bassoon servo drive contains grounding conduits for electric current protection. Any disruption to these conduits may cause the device to become “hot” (live) and dangerous.
- After shutting off the power and removing the power source from your equipment, wait at least 1 minute before touching or disconnecting parts of the equipment that are normally loaded with electrical charges (such as capacitors or contacts). Measuring the electrical contact points with a meter before touching the equipment is recommended.



1.2. Cautions

- The Bassoon servo drive contains hot surfaces and electrically charged components during operation.
- The maximum AC power supply connected to the instrument must comply with the parameters outlined in this guide.
- The Bassoon drive must be connected to an approved 24 VDC auxiliary power supply through a line that is separated from hazardous line voltages using reinforced or double insulation in accordance with approved safety standards.
- The Bassoon X/230 series is designed to get its power from a 30 to 255 VAC single phase power source. It can be connected directly to the line voltage. An isolation transformer is not needed.
- Before switching on the Bassoon, verify that all safety precautions have been observed and that the installation procedures in this manual have been followed.
- Do not clean any of the Bassoon drive's soldering with solvent cleaning fluids of pH greater than 7 (8 to 14). The solvent corrodes the plastic cover causing cracks and eventual damage to the drive's PCBs.

Elmo recommends using the cleaning fluid Vigon-EFM which is pH Neutral (7).

For further technical information on this recommended cleaning fluid, select the link:

http://www.zestron.com/fileadmin/zestron.com-usa/daten/electronics/Product_TI1s/TI1-VIGON_EFM-US.pdf

1.3. Directives and Standards

The Bassoon conforms to the following industry safety standards:

Safety Standard	Item
Approved IEC/EN 61800-5-1, Safety	Adjustable speed electrical power drive systems
Recognized UL 508C	Power Conversion Equipment
In compliance with UL 840	Insulation Coordination Including Clearances and Creepage Distances for Electrical Equipment
In compliance with UL 60950-1 (formerly UL 1950)	Safety of Information Technology Equipment Including Electrical Business Equipment
In compliance with EN 60204-1	Low Voltage Directive, 73/23/EEC

The Bassoon servo drive has been developed, produced, tested and documented in accordance with the relevant standards. Elmo Motion Control is not responsible for any deviation from the configuration and installation described in this documentation. Furthermore, Elmo is not responsible for the performance of new measurements or ensuring that regulatory requirements are met.

1.4. CE Marking Conformance

The Bassoon servo drive is intended for incorporation in a machine or end product. The actual end product must comply with all safety aspects of the relevant requirements of the European Safety of Machinery Directive 98/37/EC as amended, and with those of the most recent versions of standards **EN 60204-1** and **EN 292-2** at the least.

According to Annex III of Article 13 of Council Directive 93/68/EEC, amending Council Directive 73/23/EEC concerning electrical equipment designed for use within certain voltage limits, the Bassoon meets the provisions outlined in Council Directive 73/23/EEC. The party responsible for ensuring that the equipment meets the limits required by EMC regulations is the manufacturer of the end product.

1.5. Warranty Information

The products covered in this manual are warranted to be free of defects in material and workmanship and conform to the specifications stated either within this document or in the product catalog description. All Elmo drives are warranted for a period of 12 months from the time of installation, or 18 months from time of shipment, whichever comes first. No other warranties, expressed or implied — and including a warranty of merchantability and fitness for a particular purpose — extend beyond this warranty.

Chapter 2: Introduction

This installation guide describes the Bassoon servo drive and the steps for its wiring, installation and powering up. Following these guidelines ensures maximum functionality of the drive and the system to which it is connected.

2.1. Drive Description

The Bassoon is a powerful servo drive that operates in digital current, velocity, position and advanced position modes, in conjunction with a permanent-magnet synchronous brushless motor or DC brush motor. The Bassoon features flexible sinusoidal and trapezoidal commutation, with vector control. The Bassoon can operate as a stand-alone device or as part of a multi-axis network in a distributed configuration.

The Bassoon drive is set up and tuned using Elmo's Composer software. This Windows-based application enables users to quickly and simply configure the servo drive for optimal use with their motor.

The Bassoon connects directly to 110/230 VAC single-phase power source. A separate 24 VDC power supply serves as both the auxiliary supply *and* the backup supply. This allows a safe and economical "power backup" feature that is essential for positioning systems.

Two variations of the Bassoon are available: the *Standard* version and the *Advanced* version, which features advanced positioning capabilities. Both versions operate with RS-232 and/or CAN communications.

2.2. Product Features

2.2.1. Current Control

- Fully digital
- Sinusoidal commutation with vector control or trapezoidal commutation with resolver, encoder and/or digital Hall sensors
- 12-bit current loop resolution
- Automatic gain scheduling, to compensate for variations in the DC bus power supply

2.2.2. Velocity Control

- Fully digital
- Programmable PI and FFW (feed forward) control filters
- Sample rate two times current loop sample time
- "On-the-fly" gain scheduling
- Automatic, manual and advanced manual tuning and determination of optimal gain and phase margins

2.2.3. Position Control

- Programmable PIP control filter
- Programmable notch and low-pass filters
- Position follower mode for monitoring the motion of the slave axis relative to a master axis, via an auxiliary encoder input
- Pulse-and-direction inputs
- Sample time: four times that of current loop
- Fast event capturing inputs

2.2.4. Advanced Position Control (*Advanced model only*)

- Position-based and time-based ECAM mode that supports a non-linear follower mode, in which the motor tracks the master motion using an ECAM table stored in flash memory
- PT and PVT motion modes
- Dual (position/velocity) loop
- Fast output compare (OC)

2.2.5. Communication Options

Depending on the application, Bassoon users can select from two communication options:

- RS-232 serial communication
- CAN for fast communication in a multi-axis distributed environment

2.2.6. Feedback Options

- Incremental Encoder – up to 20 Mega-Counts (5 Mega-Pulse) per second
- Digital Halls – up to 2 KHz
- Incremental Encoder with Digital Halls for commutation – up to 20 Mega-Counts per second for encoder
- Absolute Encoder
- Interpolated Analog (Sine/Cosine) Encoder – up to 250 KHz (analog signal)
 - Internal Interpolation – programmable up to X4096
 - Automatic Correction of:
 - amplitude mismatch
 - phase mismatch
 - signals offset
 - Encoder outputs, buffered, differential

- Resolver
 - Programmable 10 to 15 bit resolution
 - Up to 512 revolutions per second (RPS)
 - Encoder outputs, buffered, differential
- Tachometer and Potentiometer
 - Two inputs for Tachometer Feedback:
 - Up to ± 50 VDC
 - Up to ± 20 VDC
 - Potentiometer Feedback:
 - 0 to 5 V voltage range
 - Resistance: 100 Ω to 1000 Ω
- Elmo drives provide supply voltage for all the feedback options.

2.2.7. Fault Protection

The Bassoon includes built-in protection against possible fault conditions, including:

- Software error handling
- Status reporting for a large number of possible fault conditions
- Protection against conditions such as excessive temperature, under/over voltage, loss of commutation signal, short circuits between the motor power outputs and between each output and power input/return
- Recovery from loss of commutation signals and from communication errors

2.3. System Architecture

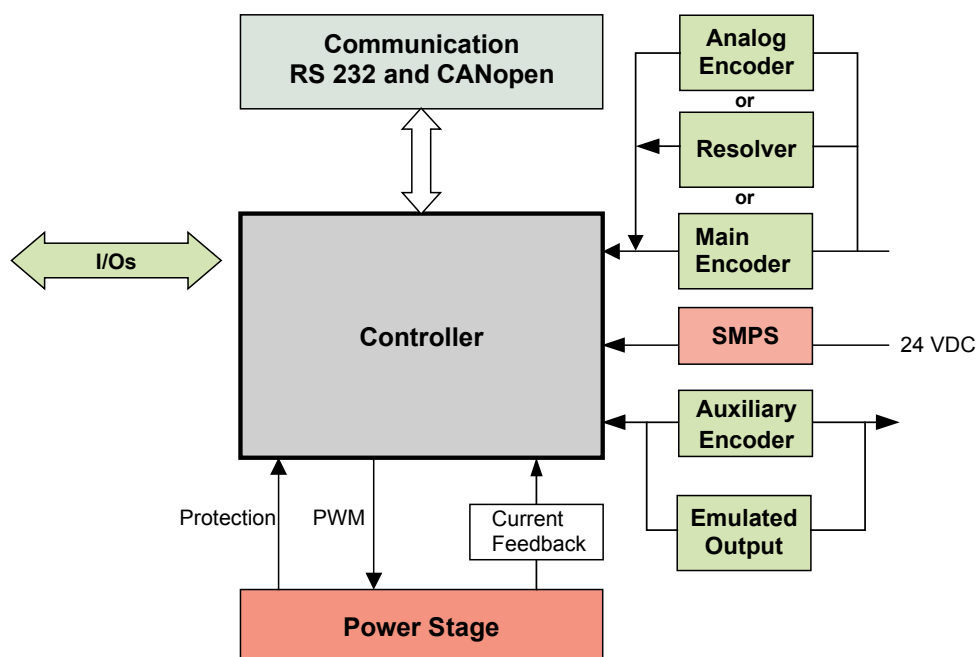


Figure 1: Bassoon System Block Diagram

2.4. How to Use this Guide

In order to install and operate your Elmo Bassoon servo drive, you will use this manual in conjunction with a set of Elmo documentation. Installation is your first step; after carefully reading the safety instructions in the first chapter, the following chapters provide you with installation instructions as follows:

- **Chapter 3, *Installation***, provides step-by-step instructions for unpacking, mounting, connecting and powering up the Bassoon.
- **Chapter 4, *Technical Specifications***, lists all the drive ratings and specifications.

Upon completing the instructions in this guide, your Bassoon servo drive should be successfully mounted and installed. From this stage, you need to consult higher-level Elmo documentation in order to set up and fine-tune the system for optimal operation. The following figure describes the accompanying documentation that you will require.

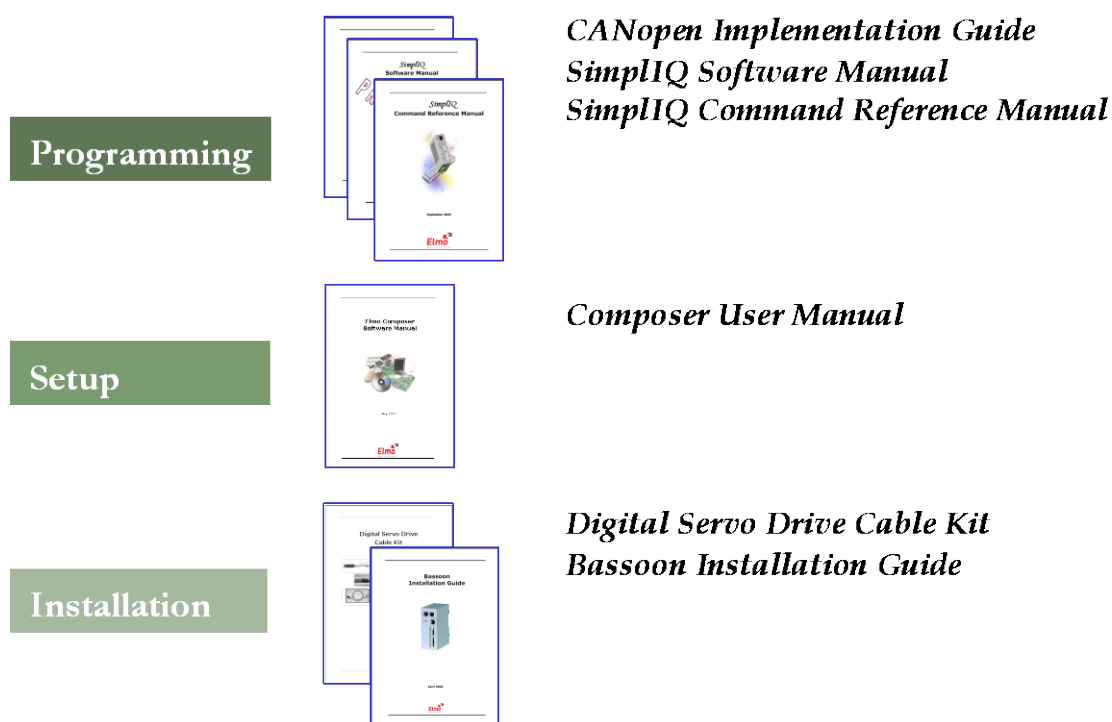


Figure 2: Elmo Documentation Hierarchy

As depicted in the previous figure, this installation guide is an integral part of the Bassoon documentation set, comprising:

- The *Composer Software Manual*, which includes explanations of all the software tools that are part of Elmo’s Composer software environment.
- The *SimplIQ Command Reference Manual*, which describes, in detail, each software command used to manipulate the Bassoon motion controller.
- The *SimplIQ Software Manual*, which describes the comprehensive software used with the Bassoon.

Chapter 3: Installation

The Bassoon must be installed in a suitable environment and properly connected to its voltage supplies and the motor.

3.1. Before You Begin

3.1.1. Site Requirements

You can guarantee the safe operation of the Bassoon by ensuring that it is installed in an appropriate environment.

Feature	Value
Ambient operating temperature	0 °C to 40 °C (32 °F to 104 °F)
Maximum operating altitude	2,000 m (6562 feet)
Maximum relative humidity	90% non-condensing
Operating area atmosphere	No flammable gases or vapors permitted in area
Models for extended environmental conditions are available.	



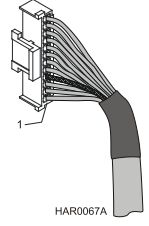
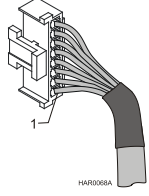
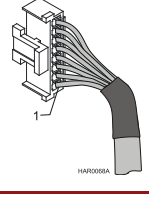
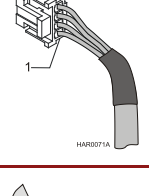
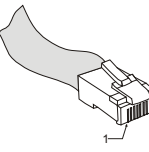
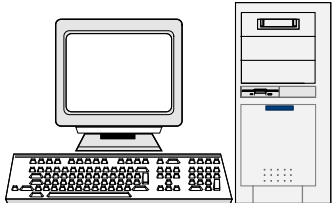

Caution:

The Bassoon drive dissipates heat by natural convection. The maximum operating ambient temperature of 0 °C to 40 °C (32 °F to 104° F) must not be exceeded.

3.1.2. Hardware Requirements

The components that you will need to install your Bassoon are:

Component	Connector	Described in Section	Drawing
Main Power Cable	Power Connector	3.5.2.2	
Motor Cable	Power Connector	3.5.2.2	
Auxiliary Power Cable	J4	3.5.3	

Component	Connector	Described in Section	Drawing
Main Feedback Cable	J3	3.5.5	
Auxiliary Feedback (if needed)	J2	3.5.6	
Digital Input Cable (if needed)	J5	3.5.6	
Digital Output Cable (if needed)	J6	3.5.6	
Communication Cables (RS-232 and/or CANopen)	J1, J8, J9	3.5.8	
PC for drive setup and tuning			
Motor data sheet or manual			



Parameter	Value	Unit	Value	Unit
Supply Voltage (VAC)	230	V	115	V
Current (A)	1.0	A	1.0	A
Speed (rpm)	1500	rpm	1500	rpm
Power (W)	150	W	150	W
...

3.1.3. AC Power Requirements

Below are the Bassoon’s AC power requirements:

Component	Single-Phase Supply Voltage
Circuit breaker current rating	200% to 300% of drive current
Circuit breaker voltage rating	230 VAC
Contactors	Up to 200% of drive current

3.2. Unpacking the Drive Components

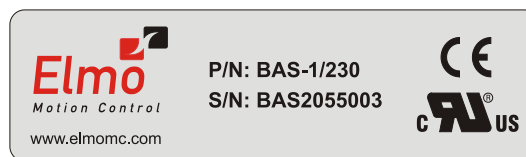
Before you begin working with the Bassoon system, verify that you have all of its components, as follows:

- The Bassoon servo drive
- The Composer software and software manual
- The Bassoon cable kit (if ordered separately)

The Bassoon is shipped in a cardboard box with Styrofoam protection.

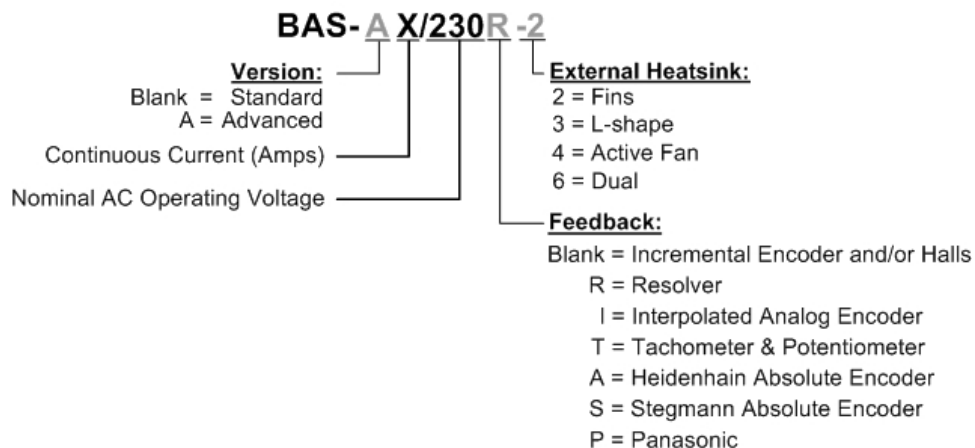
To unpack the Bassoon:

1. Carefully remove the servo drive from the box and the Styrofoam.
2. Check the drive to ensure that there is no visible damage to the instrument. If any damage has occurred, report it immediately to the carrier that delivered your drive.
3. To ensure that the Bassoon you have unpacked is the appropriate type for your requirements, locate the part number sticker on the side of the Bassoon. It looks like this:



BAS0027A

The P/N number at the top gives the type designation as follows:



4. Verify that the Bassoon type is the one that you ordered.

3.3. Assembling the Heatsink

When an external heatsink device is required, attach it with four screws to the left side of the Bassoon, as depicted in the following diagrams.

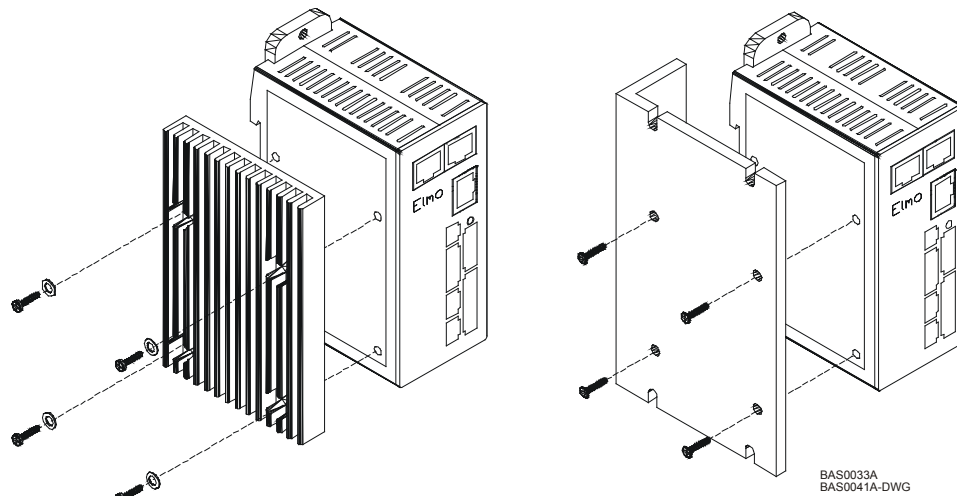


Figure 3: Attaching the Heatsink

To mount the finned heatsink use M4 screws and spring washers. To mount the L-shaped heatsink use conical head M4 screws.

3.4. Mounting the Bassoon

The Bassoon has been designed for two standard mounting options:

- Mounting on a DIN rail
- Attaching directly to a wall with screws

3.4.1. Mounting on a DIN Rail

At the top rear of the Bassoon, a horizontal groove lets you quickly and easily snap the drive onto a DIN rail in your work area.

To mount the Bassoon on a DIN rail:

1. If the mounting tab is attached to the top of the Bassoon, remove it by pushing it down and slipping it out of the slot (see the figure below).
2. Mount the upper slit on the back of the Bassoon on the upper edge of the DIN rail.
3. Tilt the bottom of the Bassoon towards the bottom of the DIN rail until you hear a click.

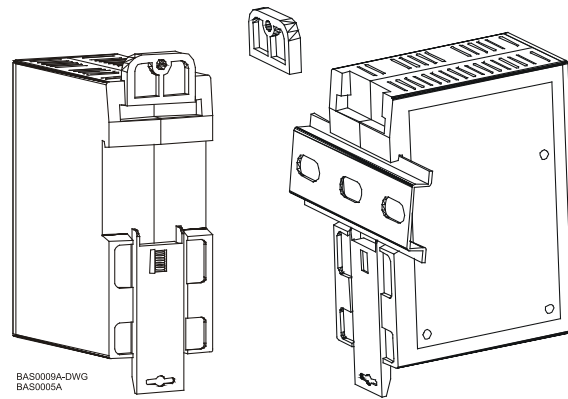


Figure 4: Mounting the Bassoon on a DIN Rail

3.4.2. Mounting Directly onto a Wall

The mounting strips at the back of the Bassoon enable it to be screwed directly into a wall. If it is not already assembled in the upper slot in the back of the Bassoon, assemble the upper mounting tab now.

To mount the Bassoon onto a wall:

1. On the back of the drive, fully extend the top mounting strip so that the ends with the holes are exposed. (The bottom strip is delivered already extended.)
2. Mount the Bassoon vertically onto the wall with two M4 round head screws and washers, one through the top hole of the mounting strip and one at the bottom.

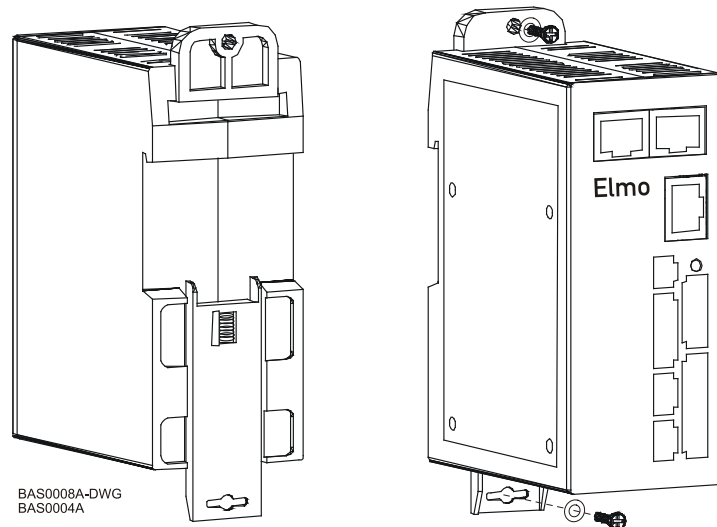


Figure 5: Extending the Mounting Strips and Attaching the Screws

3.5. Connecting the Cables

The Bassoon has 10 connectors.

3.5.1. Wiring the Bassoon

Once the Bassoon is mounted, you are ready to wire the device. Proper wiring, grounding and shielding are essential for ensuring safe, immune and optimal servo performance of the Bassoon.



Caution:

Follow these instructions to ensure safe and proper wiring:

- Use twisted-pair shielded wires for control, feedback and communication ports. For best results, use an aluminum foil shield covered by copper braid with a drain wire.
The drain wire is a non-insulated wire that is in contact with parts of the cable, usually the shield. It is used to terminate the shield and as a grounding connection.
- The impedance of the wire must be as low as possible. The size of the wire must be thicker than actually required by the carrying current. 24 or 26 AWG wire for control and feedback cables is satisfactory.
- Use shielded wires for motor connections as well. If the wires are long, ensure that the capacitance between the wires is not too high: $C < 30 \text{ nF}$ is satisfactory for most applications.
- Keep all wires and cables as short as possible.
- Keep the motor wires as far away as possible from the feedback, control and communication cables.
- Ensure that in normal operating conditions, the shielded wires and drain *carry no current*. The only time these conductors carry current is under abnormal conditions, when electrical equipment has become a potential shock or fire hazard while conducting external EMI interferences directly to ground, in order to prevent them from affecting the drive. Failing to meet this requirement can result in drive/controller/host failure.
- After completing the wiring, carefully inspect all wires to ensure that the crimp terminals are firmly attached to the wire ends and that the wires are firmly connected to their connectors.

The following connectors are used for wiring the Bassoon.

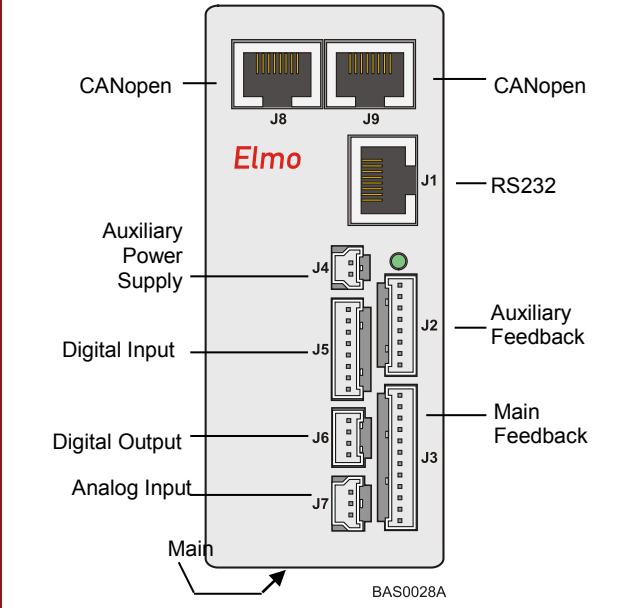
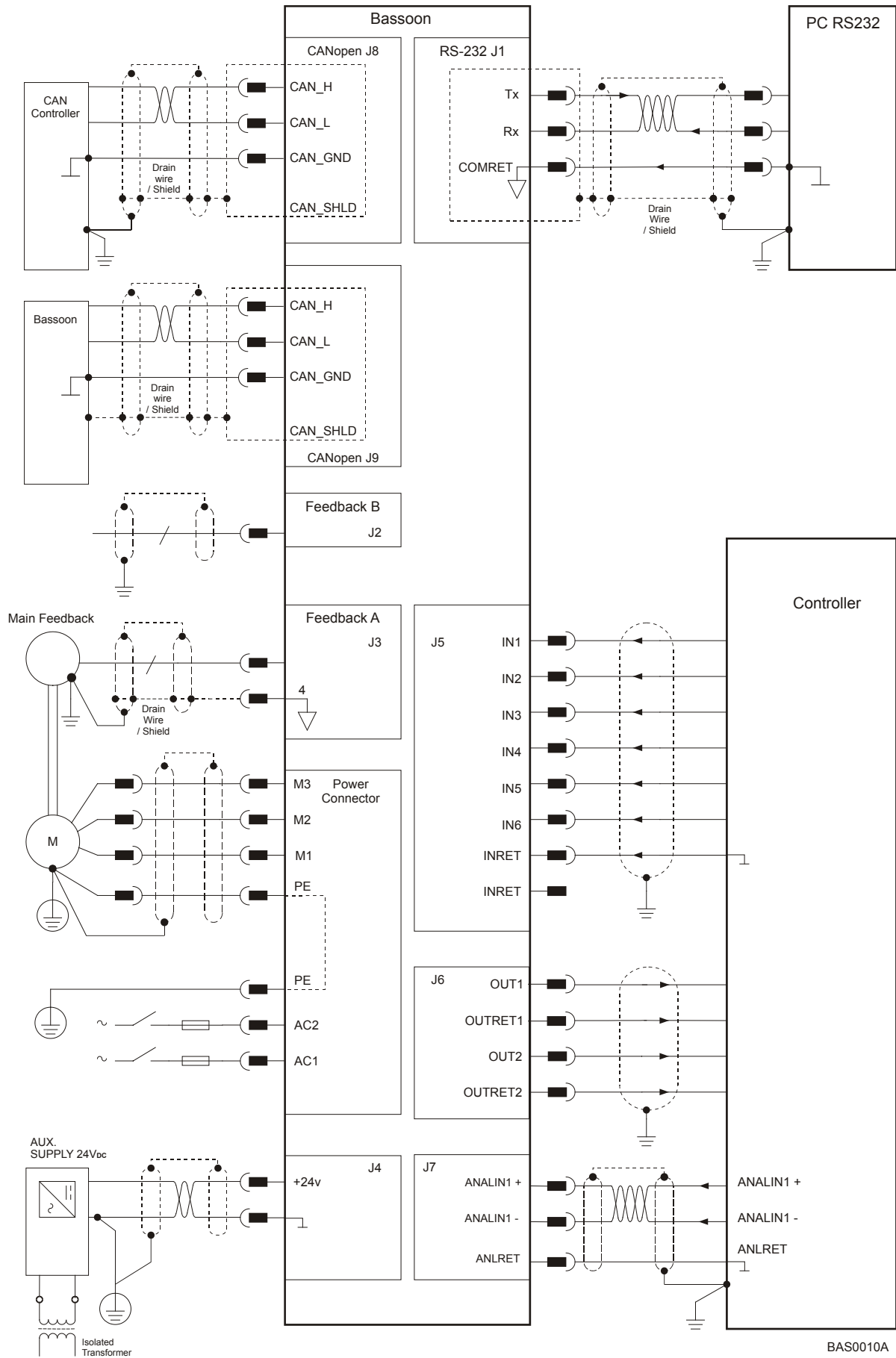
Port	Type	Function	Connector Location
J8	8-Pin RJ-45	CANopen	
J9	8-Pin RJ-45	CANopen	
J1	8-Pin RJ-45	RS-232	
J2	8-Pin Molex	Auxiliary Feedback	
J3	12-Pin Molex	Main Feedback	
J4	2-Pin Molex	Auxiliary power supply	
J5	8-Pin Molex	Digital input	
J6	4-Pin Molex	Digital output	
J7	3-Pin Molex	Analog input	
Power	7-Pin Phoenix	Main power	

Table 1: Bassoon Connectors



BAS0010A

Figure 6: Bassoon Detailed Connection Diagram

3.5.2. Connecting the Power Cables

The main power connector, which is located on the bottom of the Bassoon, includes the following pins:

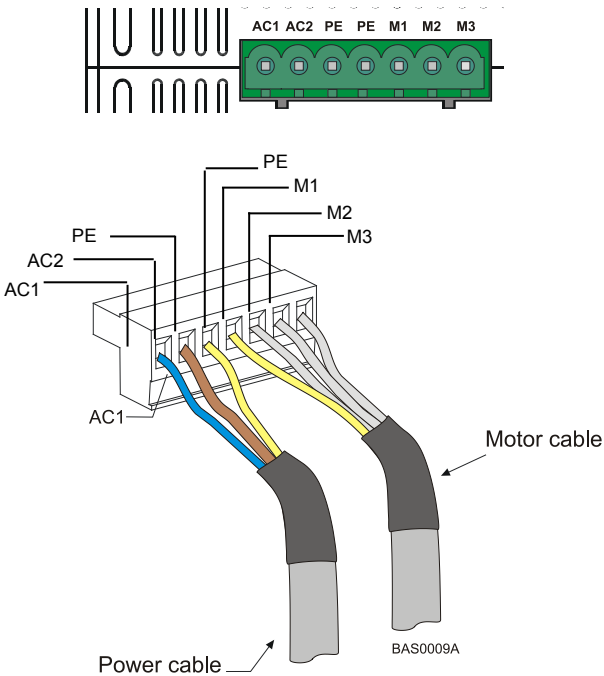
Pin	Function	Cable		Pin Positions
AC1	Main Voltage Phase 1	Power		
AC2	Main Voltage Phase 2	Power		
PE	Protective earth	Power		
		AC Motor Cable	DC Motor Cable	
PE	Protective earth	Motor	Motor	
M1	Motor phase	Motor	N/C	
M2	Motor phase	Motor	Motor	
M3	Motor phase	Motor	Motor	
<p>Note: When connecting several motors, all must be wired in an identical manner.</p>				

Table 2: Connector for Main Power and Motor Cables

3.5.2.1. Connecting the Motor Cable

Connect the motor power cable to the M1, M2, M3 and PE terminals of the main power connector. The phase connection order is arbitrary because the Composer will establish the proper commutation automatically during setup. However, if you plan to copy the set-up to other drives, then the phase order on all copy drives must be the same.

Notes for connecting the motor cables:

- For best immunity, it is highly recommended to use a shielded (not twisted) cable for the motor connection. A 4-wire shielded cable should be used. The gauge is determined by the actual current consumption of the motor.
- Connect the shield of the cable to the closest ground connection at the motor end.
- The fourth wire should be used for the ground connection between the motor and the second PE terminal of the Bassoon.
- Be sure that the motor chassis is properly grounded.

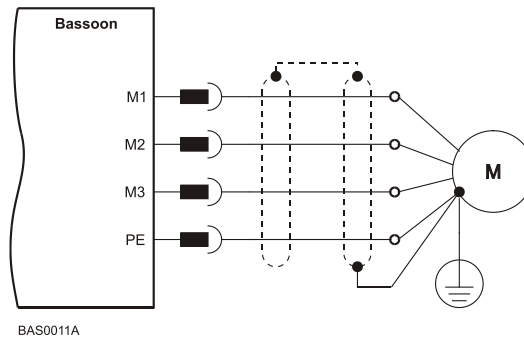


Figure 7: AC Motor Power Connection Diagram

3.5.2.2. Connecting the Main Power Cable

Connect the main power supply cable to the AC1, AC2 and PE terminals of the main power connector.

Notes for connecting the AC power cable:

- For best immunity, a shielded (not twisted) cable is recommended (not mandatory) for the AC power supply cable. A 3-wire shielded cable should be used. The gauge is determined by the actual current consumption of the motor.
- Connect the two power wires (Neutral and Phase) to the AC power leads of the source.
- For safety requirements, the third wire must be used for the protective earth connection (connected to the PE terminal).

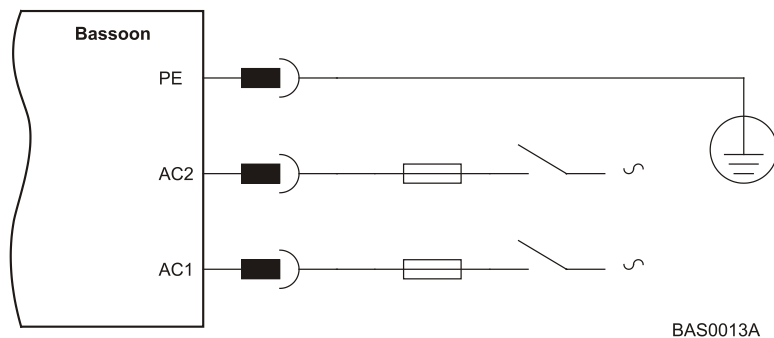


Figure 8: Main Power Supply Connection Diagram

3.5.3. Connecting the Auxiliary Power Cable (J4)

Connect the auxiliary power supply to the J4 port on the front of the Bassoon, using a 2-pin Molex plug. Remember, you are working with DC power; be sure to exercise caution. The required voltage is 24 VDC.

Notes for 24 VDC auxiliary power supply connections:

- Use a 24 or 26 AWG twisted pair shielded cable.
- The 24 VDC auxiliary power supply must meet all safety requirements and must be separated from hazardous live voltages using reinforced or double insulation in accordance with approved safety standards.
- For safety reasons, connect the return (common) of the 24 VDC source to the closest ground.
- Connect the cable shield to the closest ground near the 24 VDC source.
- Before applying power, first verify the polarity of the connection.

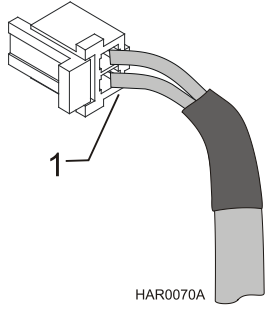
Pin	Signal	Function	Pin Positions
1	+24VDC	+24 VDC auxiliary power supply	 <p>HAR0070A</p>
2	RET24VDC	Return (common) of the 24 VDC auxiliary power supply	

Table 3: Auxiliary Power Cable Plug

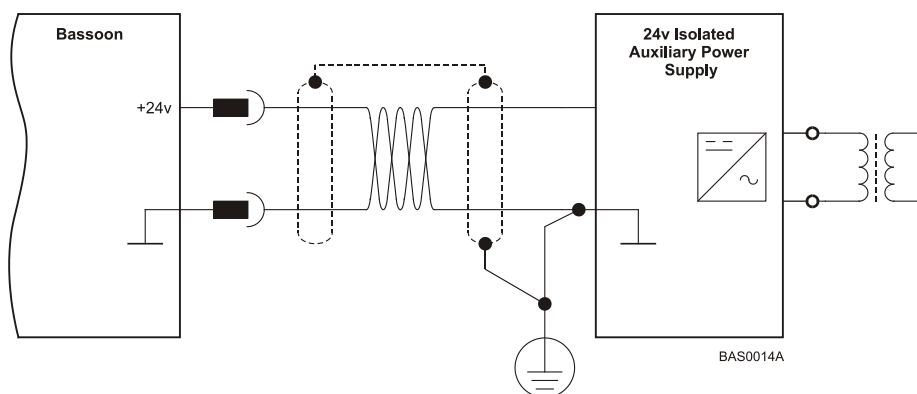


Figure 9: Auxiliary Power Supply (J4) Connection Diagram

3.5.4. Feedback and Control Cable Assemblies

The Auxiliary Power Cable (J4), the Feedback cables (J2 and J3) and the I/O cables (J5, J6 and J7) all use 2 mm pitch Molex “Sherlock” connectors. These connectors snap together quite easily, but require a small standard screwdriver for disassembly. To disassemble the Molex connector simply (1) slip the screwdriver into the lock (this will cause the lock to disengage) and (2) twist the screwdriver downward with light pressure on the handle (see the figure below).

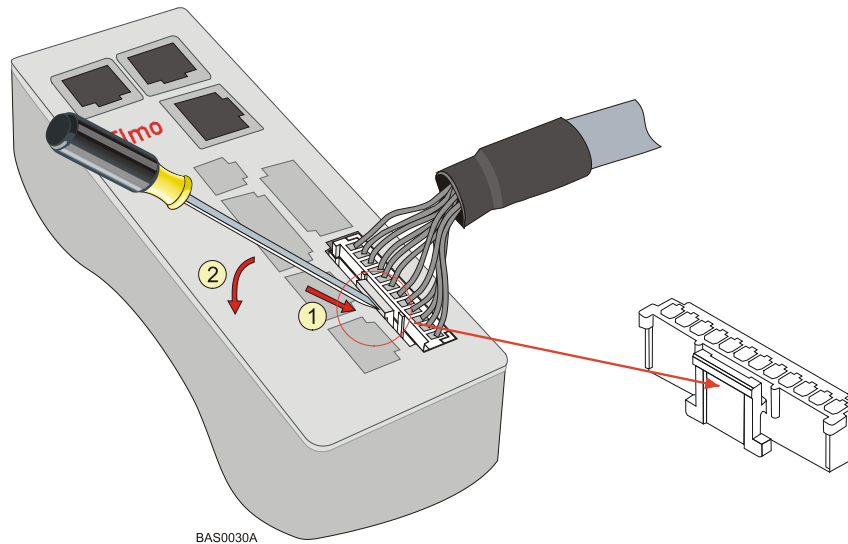


Figure 10: Disconnecting Molex Connectors

Notes for assembling Feedback and Control cable assemblies:

- Use 24 or 26 AWG twisted-pair shielded cables.
- On the motor side connections, ground the shield to the motor chassis.
- On controller side connections, follow the controller manufacturer’s recommendations concerning shield and/or drain wire connections.

3.5.5. Main Feedback Cable (Port J3)

The main feedback cable is used to transfer feedback data from the motor to the drive.

The Bassoon accepts the following as a main feedback mechanism:

- Incremental encoder only
- Incremental encoder with digital Hall sensors
- Digital Hall sensors only
- Incremental Analog (Sine/Cosine) encoder (option)
- Resolver (option)
- Tachometer and potentiometer
- Absolute encoder

Connect the main feedback cable from the motor to the J3 port on the front of the Bassoon, using a 12-pin Molex plug.

Notes:

- Connect the drain wire to pin 4. If the cable has no drain wire, connect the shield to pin 4.
- Ground the shield to the motor chassis.

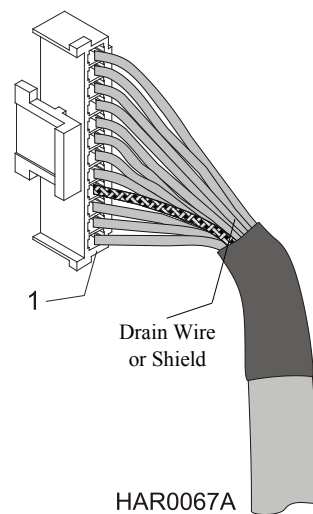


Figure 11: The Main Feedback (J3) Cable

The wiring of the Main Feedback cable depends on the type of device used. Incremental Encoder wiring, Interpolated Analog Encoder wiring and Resolver wiring are shown in the table below.

Incremental Encoder			Interpolated Analog (Sine/Cosine) Encoder		Resolver		Tachometer and Potentiometer	
BAS-XX/YYY_			BAS-XX/YYYYI		BAS-XX/YYYYR		BAS-XX/YYYYT	
Pin	Signal	Function	Signal	Function	Signal	Function	Signal	Function
1	HC	Hall sensor C input	HC	Hall sensor C input	NC	-	HC	Hall sensor C input
2	HB	Hall sensor B input	HB	Hall sensor B input	NC	-	HB	Hall sensor B input
3	HA	Hall sensor A input	HA	Hall sensor A input	NC	-	HA	Hall sensor A input
4	SUPRET	Supply return	SUPRET	Supply return	SUPRET	Supply return	SUPRET	Supply return
5	SUPRET	Supply return	SUPRET	Supply return	SUPRET	Supply return	SUPRET	Supply return
6	+5V	Encoder/Hall +5 V supply	+5V	Encoder/Hall +5 V supply	NC	-	+5V	Encoder/Hall +5 V supply
7	INDEX-	Index complement	R-	Reference complement	R2	Vref complement f= 1/TS, 50 mA Maximum	NC	-
8	INDEX	Index	R+	Reference	R1	Vref f=1/TS, 50 mA Max.	POT	Potentiometer input
9	CHB-	Channel B complement	B-	Cosine B complement	S4	Cosine B complement	Tac 2-	Tacho Input 2 Neg. (50 V max)
10	CHB	Channel B	B+	Cosine B	S2	Cosine B	Tac 2+	Tacho Input 2 Pos. (50 V max)
11	CHA-	Channel A complement	A-	Sine A complement	S3	Sine A complement	Tac 1-	Tacho Input 1 Neg. (50 V max)
12	CHA	Channel A	A+	Sine A	S1	Sine A	Tac 1+	Tacho Input 1 Pos. (50 V max)

Table 4: Main Feedback Cable Pin Assignments (Part A)

EnDat (Heidenhain) Absolute Encoder			Stegmann Absolute Encoder	
BAS-XX/YYYYA			BAS-XX/YYYYS	
Pin	Signal	Function	Signal	Function
1	CLK -	CLOCK complement	HC	-
2	CLK +	CLOCK	HB	-
3	HA	-	HA	-

EnDat (Heidenhain) Absolute Encoder			Stegmann Absolute Encoder	
4	SUPRET	Supply return	SUPRET	Supply return
5	SUPRET	Supply return	SUPRET	Supply return
6	+5V	Encoder +5 V supply voltage, 5 V @ 200 mA maximum	+8V	Encoder +8 V supply voltage, 8 V @ 90 mA maximum
7	DATA -	Data complement	DATA -	Data complement
8	DATA +	DATA	DATA +	DATA
9	B -	Cos B complement	B -	Cos B complement
10	B +	Cos B	B +	Cos B
11	A -	Sine A complement	A -	Sin A
12	A +	Sine A	A +	Sine A complement

Table 5: Main Feedback Cable Pin Assignments (Part B)

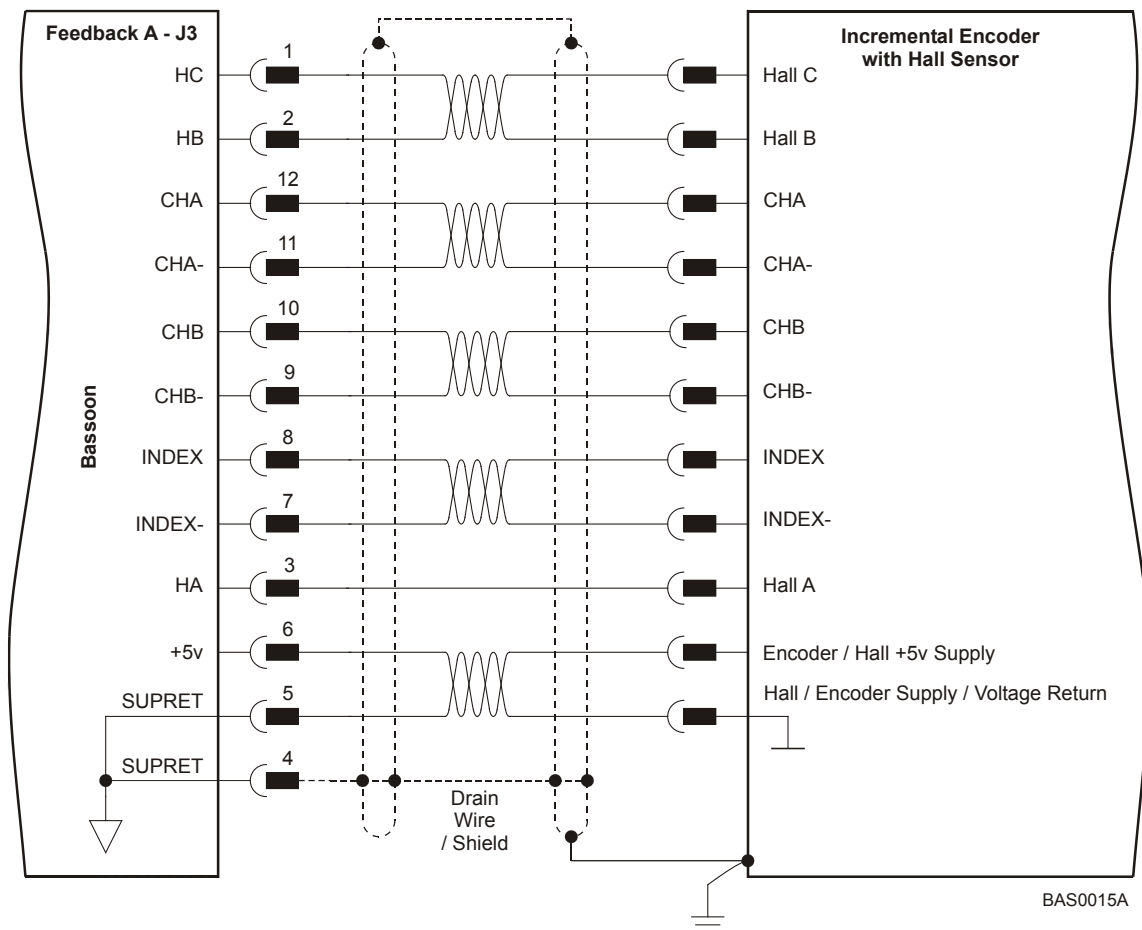
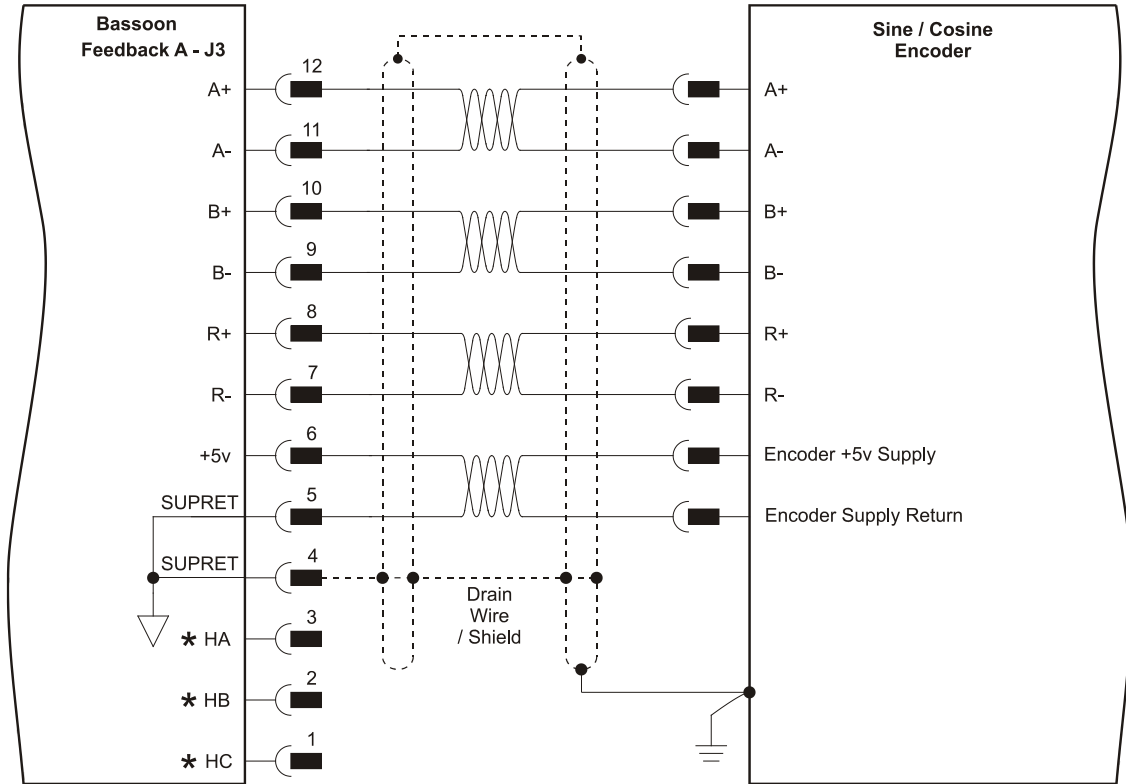


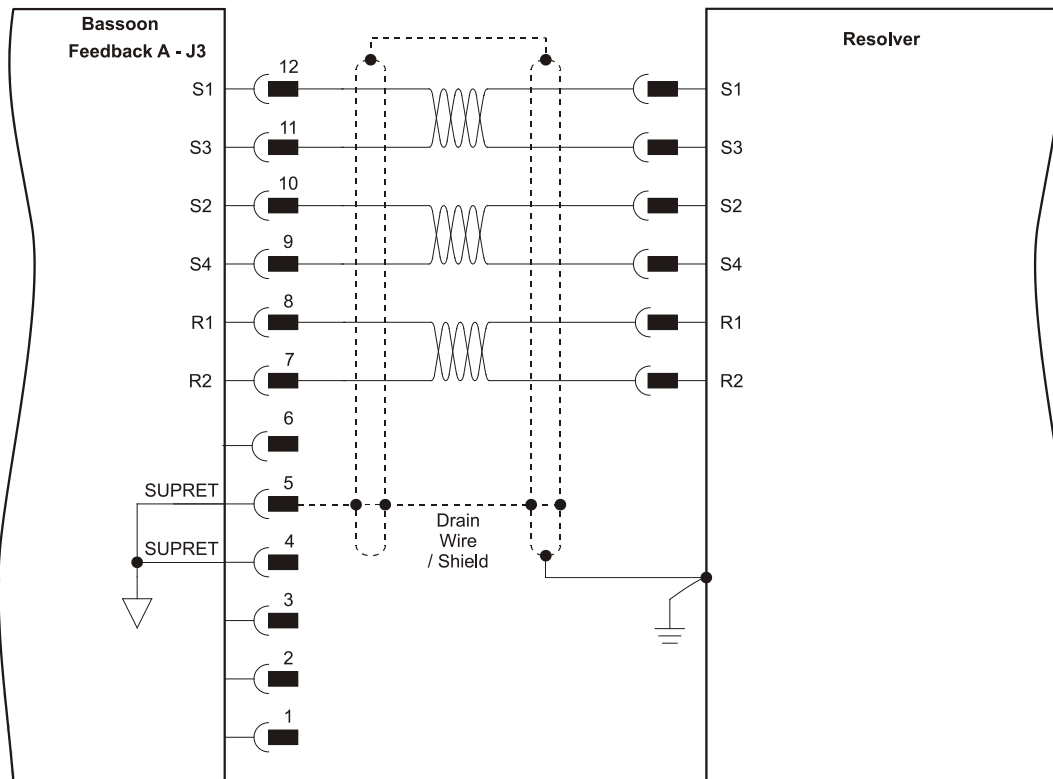
Figure 12: Main Feedback- Incremental Encoder Connection Diagram



* Halls are available for "aid commutation" feature

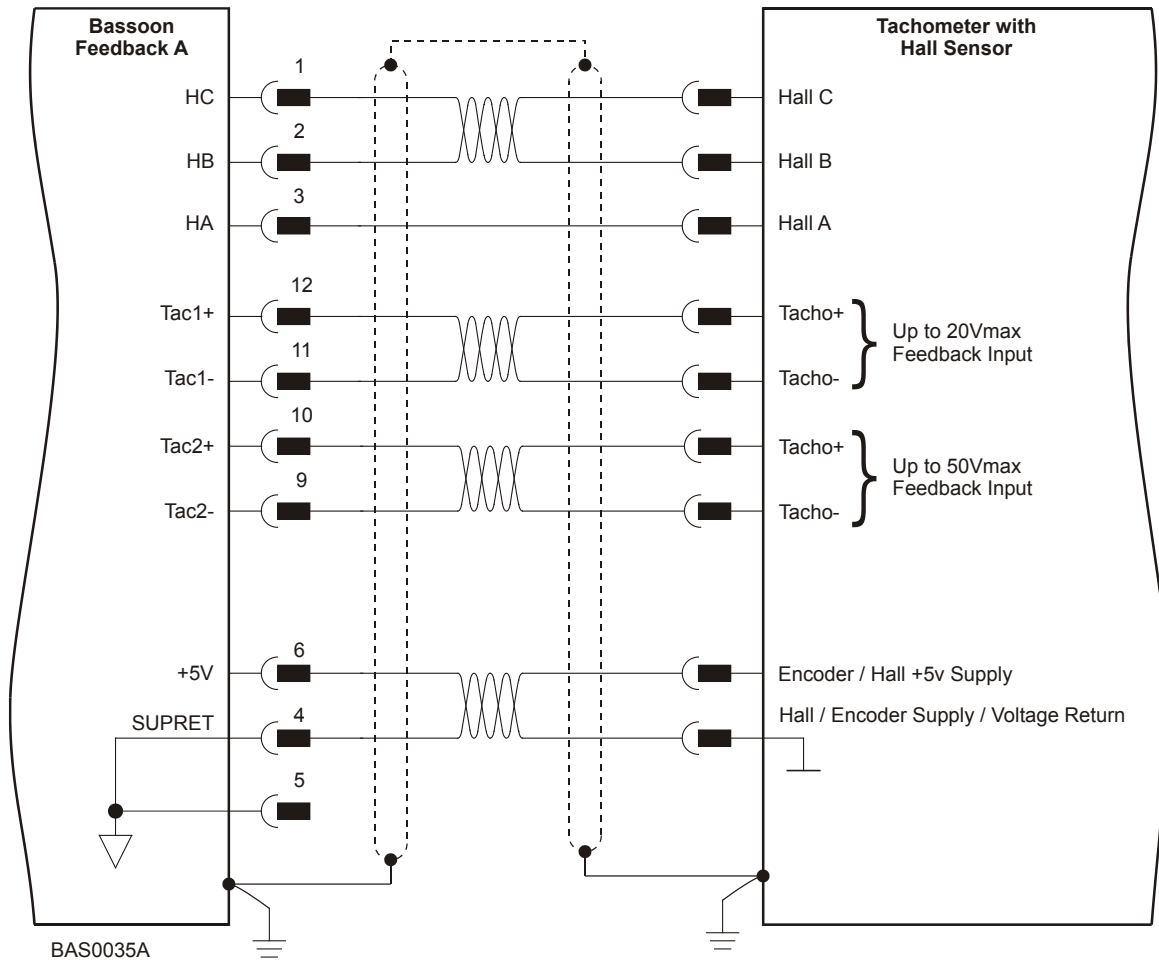
BAS0016A

Figure 13: Main Feedback – Interpolated Analog (Sine/Cosine) Encoder Connection Diagram



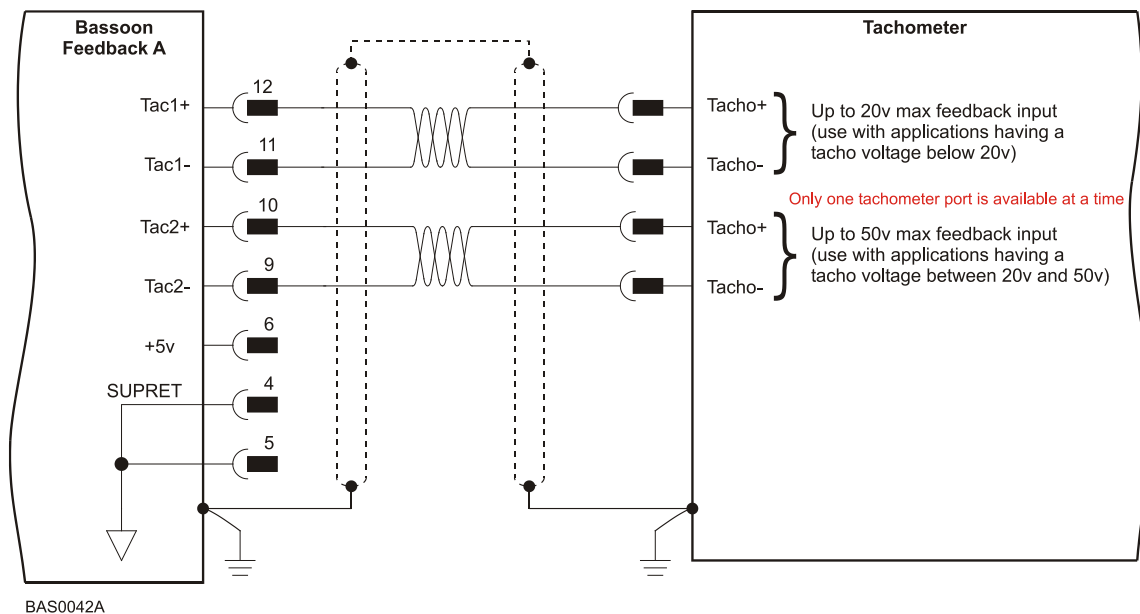
BAS0017B

Figure 14: Main Feedback – Resolver Connection Diagram



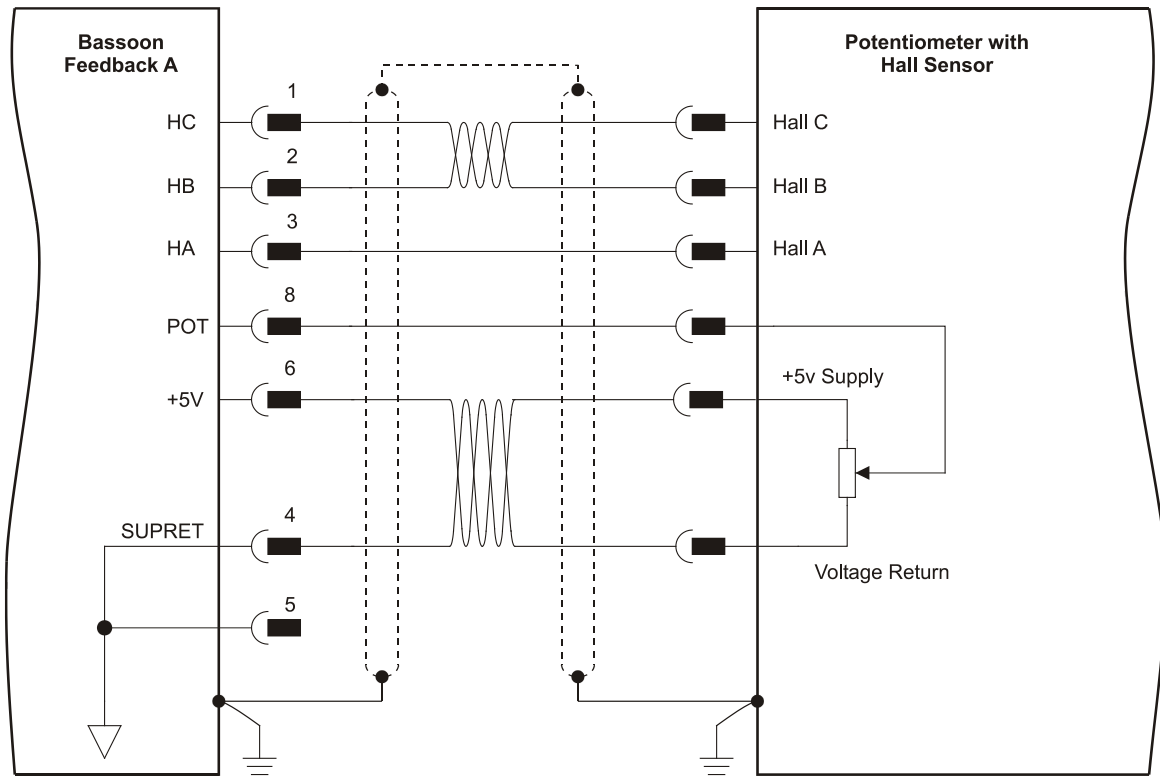
BAS0035A

Figure 15: Main Feedback – Tachometer Feedback with Digital Hall Sensor Connection Diagram for Brushless Motors



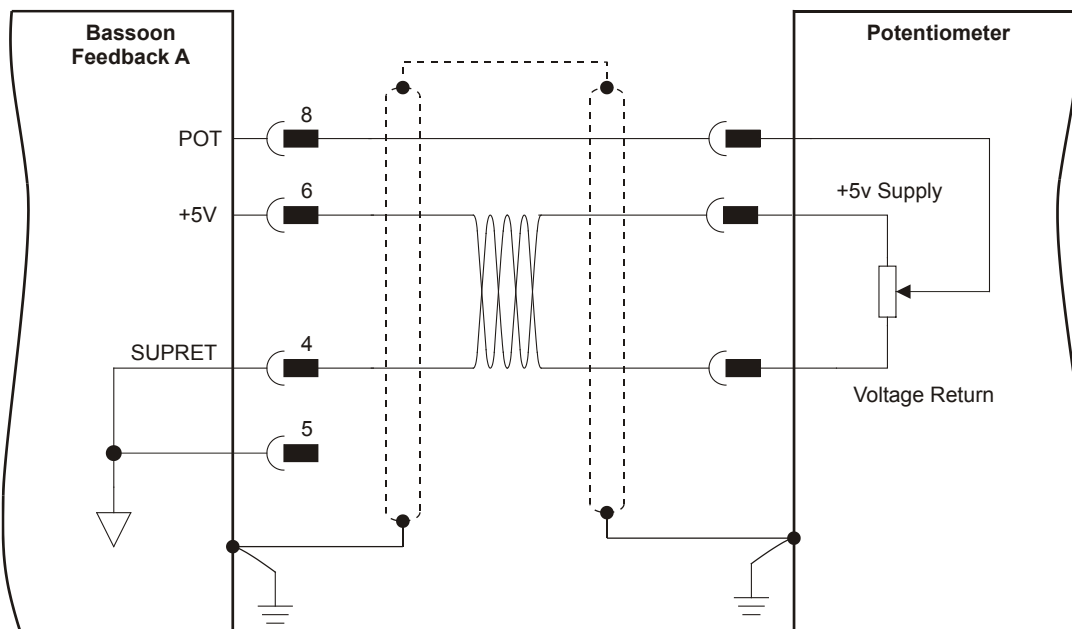
BAS0042A

Figure 16: Main Feedback – Tachometer Feedback Connection Diagram for Brush Motors



BAS0043A

Figure 17: Main Feedback – Potentiometer Feedback with Digital Hall Sensor Connection Diagram for Brushless Motors



BAS0044A

Figure 18: Main Feedback – Potentiometer Feedback Connection Diagram for Brush Motors and Voice Coils

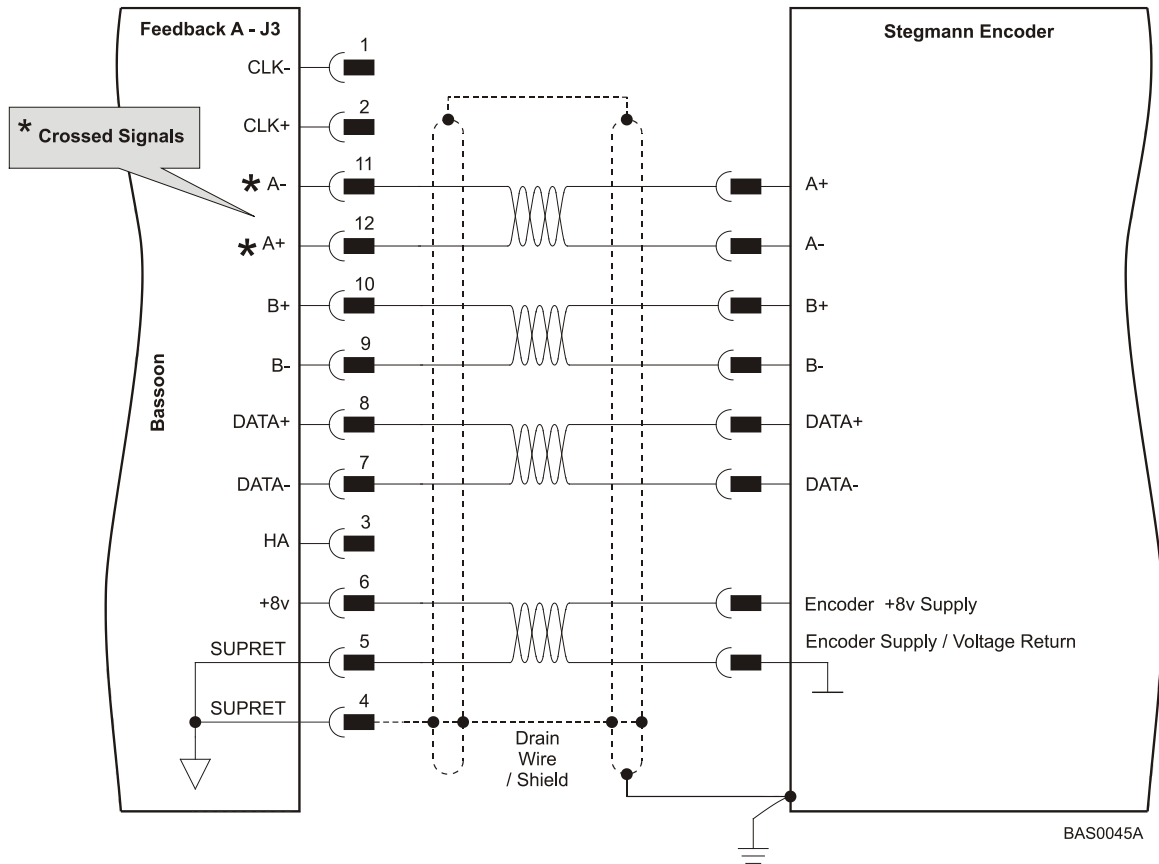


Figure 19: Main Feedback – Stegmann Feedback Connection Diagram

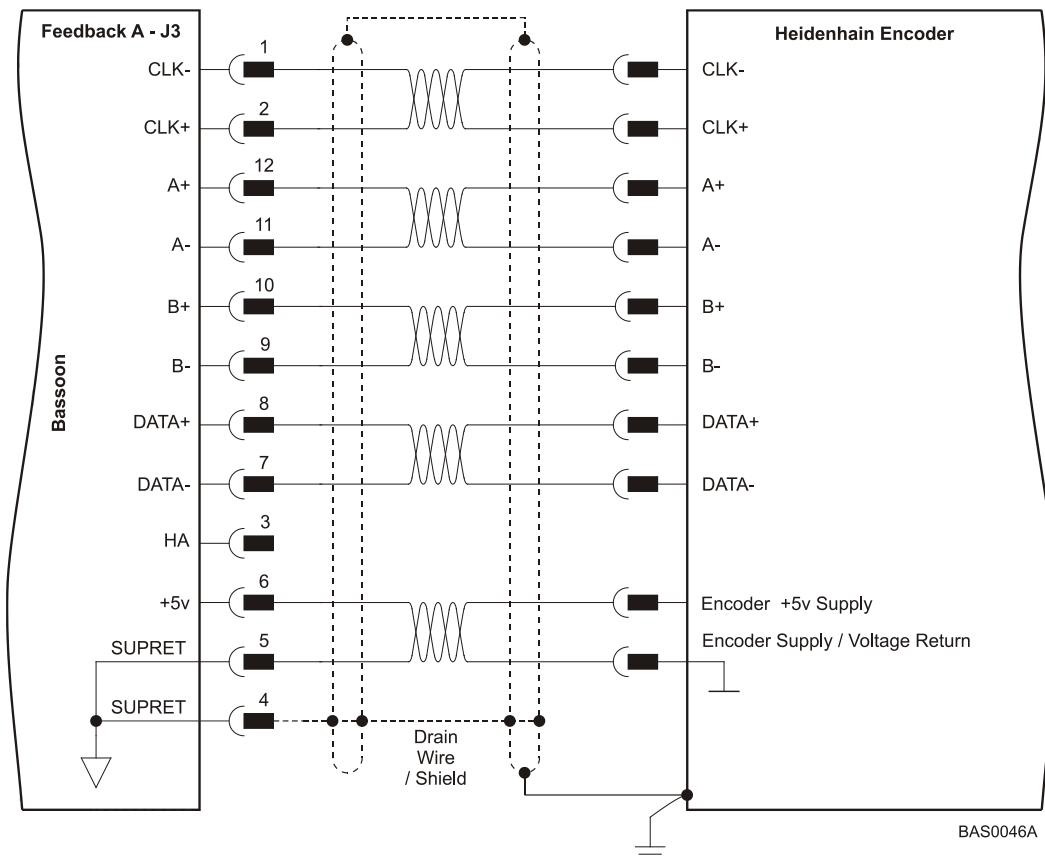


Figure 20: Main Feedback – Heidenhain Feedback Connection Diagram

3.5.6. Main and Auxiliary Feedback Combinations

The Main Feedback is always used in motion control devices whereas the Auxiliary Feedback is often, but not always used. The Auxiliary Feedback port, FEEDBACK B (J2), can be used in combination with the Main Feedback port, FEEDBACK A (J3). Feedback B can be set by software as follows:

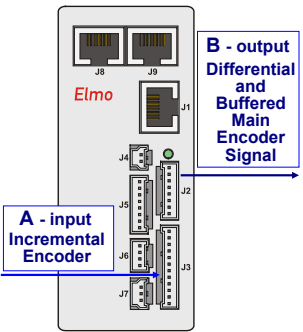
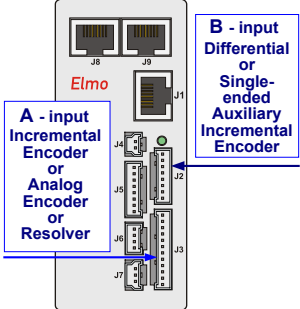
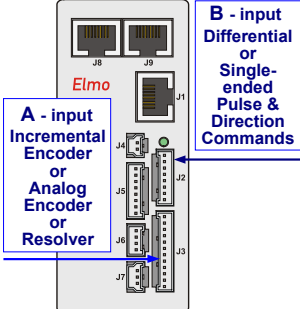
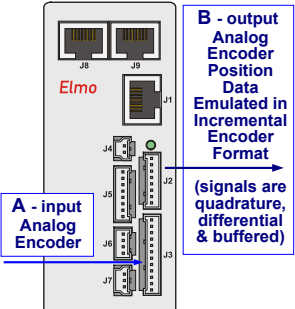
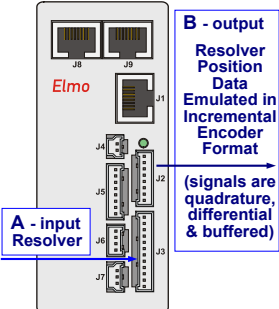
SW Setting Feedback A (J3)		Feedback B (J2)		
		YA[4] = 4	YA[4] = 2	YA[4] = 0
Incremental Encoder Input	★			
Interpolated Analog (Sin/Cos) Encoder Input	★			
Resolver Input	★			
Typical Applications		<ul style="list-style-type: none"> ★ Any application where the main encoder is used, not only for the drive, but also for other purposes such as position controllers and/or other drives. ★ Analog Encoder applications where position data is required in the Encoder's quadrature format. ★ Resolver applications where position data is required in the Encoder's quadrature format. 	<p>Any application where two feedbacks are used by the drive.</p> <p>Port B serves as an input for the auxiliary incremental encoder (differential or single-ended).</p> <p>For applications such as Follower, ECAM, or Dual Loop.</p>	<p>Port B serves as an input for Pulse & Direction commands (differential or single-ended).</p>

Table 6: Main Feedback –Auxiliary Feedback Combinations

3.5.6.1. Main Encoder Buffered Outputs or Emulated Encoder Outputs Option on Feedback B (J2) (YA[4]=4)

Through FEEDBACK B the Bassoon can provide **buffered main, or emulated, encoder signals** to another controller or drive. This option can be used when:

- The Bassoon is used as a current amplifier to provide position data to the position controller.
- The Bassoon is used in velocity mode, to provide position data to the position controller.
- The Bassoon is used as a master in Follower or ECAM mode.

Below are the signals on the Auxiliary Feedback ports when set up to run as a buffered outputs or emulated outputs of the main encoder (on FEEDBACK A):

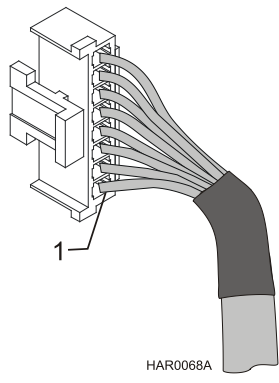
Pin	Signal	Function	Pin Positions
1	SUPRET	Supply return	
2	+5 V	NA	
3	INDEXO-	Index complement output	
4	INDEXO	Index output	
5	CHBO-	Channel B complement output	
6	CHBO	Channel B output	
7	CHAO-	Channel A complement output	
8	CHAO	Channel A output	

Table 7: Main Encoder Buffered Output or Emulated Encoder Output Pin Assignments on J2

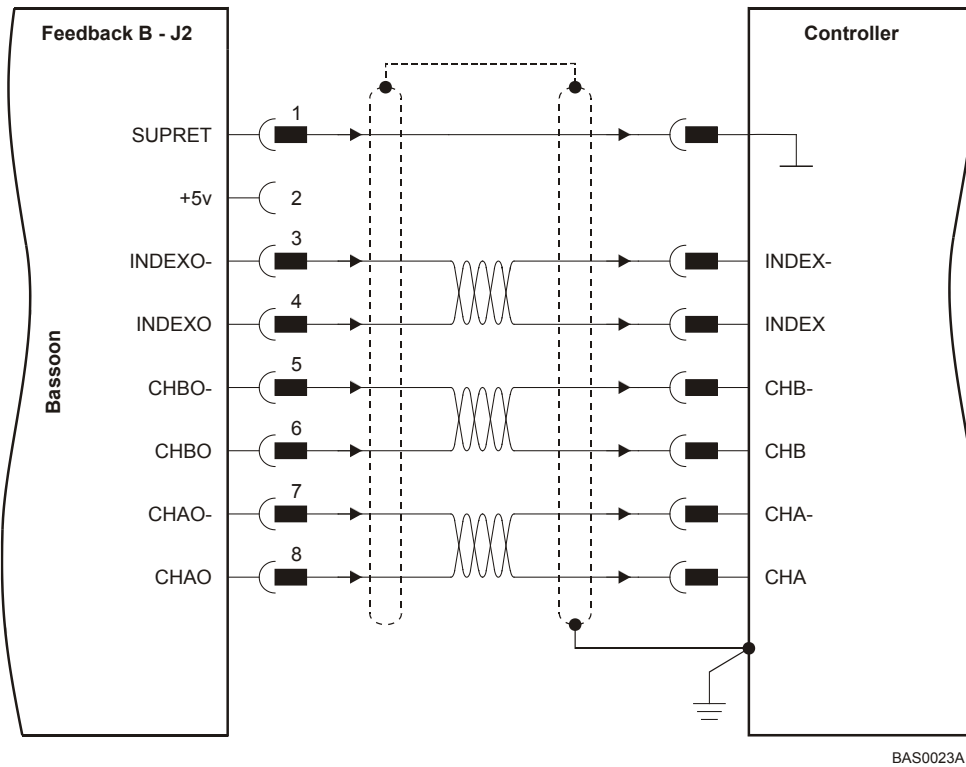


Figure 21: Main Encoder Buffered Output or Emulated Encoder Output on J2 - Connection Diagram

3.5.6.2. Differential Auxiliary Encoder Input Option on Feedback B (J2) (YA[4]=2)

The Bassoon can be used as a slave by receiving the position (on Port B) of the master encoder data in Follower or ECAM mode.

Below are the signals on the Auxiliary Feedback port when set up to run as a differential auxiliary encoder input:

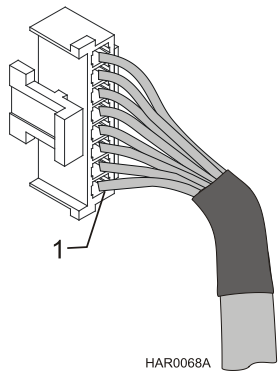
Pin	Signal	Function	Pin Positions
1	SUPRET	Supply return	
2	+5 V	Encoder + 5 V supply voltage, 5 V @ 200 mA	
3	INDEX-	Auxiliary index low input	
4	INDEX	Auxiliary index high input	
5	CHB-	Auxiliary channel B low input	
6	CHB	Auxiliary channel B high input	
7	CHA-	Auxiliary channel A low input	
8	CHA	Auxiliary channel A high input	

Table 8: Differential Auxiliary Encoder Input Pin Assignments on J2

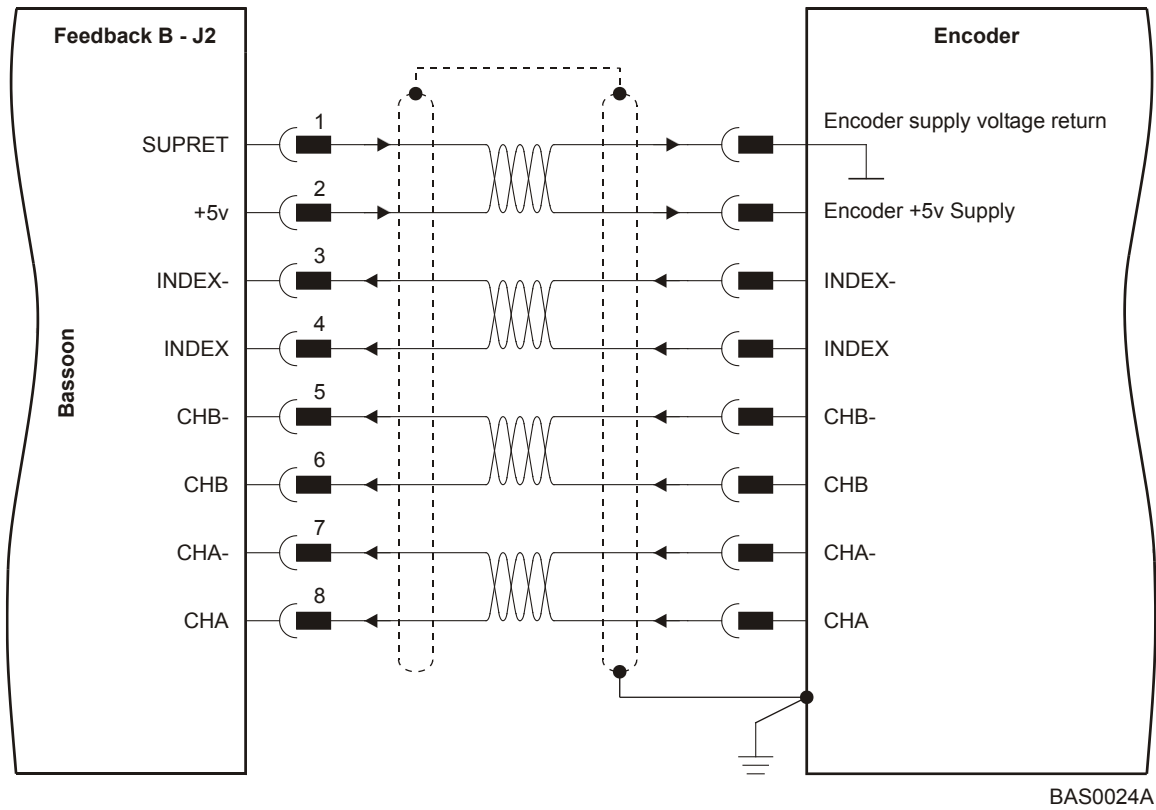


Figure 22: Differential Auxiliary Encoder Inputs on J2 - Connection Diagram

3.5.6.3. Single-Ended Auxiliary Input Option on Feedback B (J2) (YA[4]=2)

The Bassoon can be used as a slave by receiving the position data (on Port B) of the master encoder in Follower or ECAM mode.

Below are the signals on the Auxiliary Feedback port when set up to run as a single-ended auxiliary input:

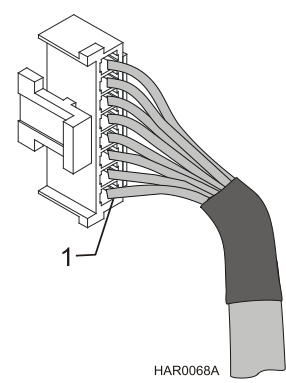
Pin	Signal	Function	Pin Positions
1	SUPRET	Supply return	
2	+5 V	Encoder/Hall +5 V supply voltage, 5 V @ 200 mA	
3	—	—	
4	INDEX	Index	
5	—	—	
6	CHB	Channel B	
7	—	—	
8	CHA	Channel A	

Table 9: Single-Ended Auxiliary Encoder Input Pin Assignments on J2

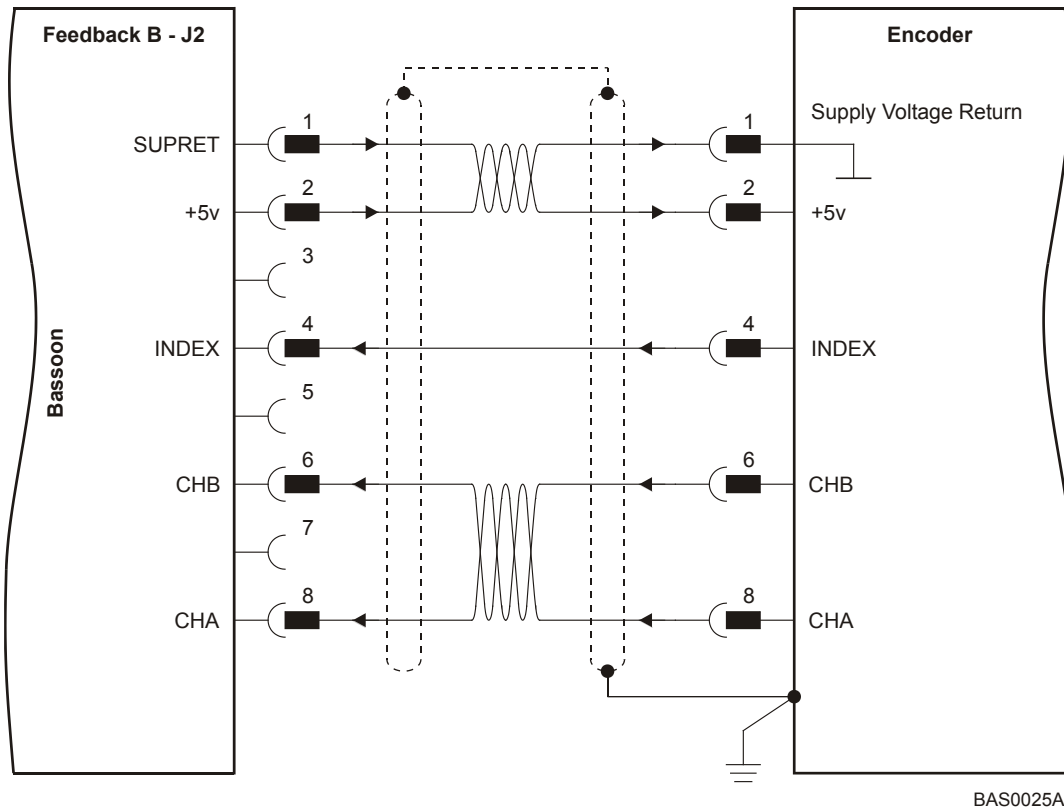


Figure 23: Single-Ended Auxiliary Encoder inputs on J2 - Connection Diagram

3.5.6.4. Pulse-and-Direction Input Option on FEEDBACK B (J2) (YA[4]=0)

This mode is used for input of differential or single-ended pulse-and-direction position commands.

Below are the signals on the Auxiliary Feedback ports when set up to run as a single-ended pulse-and-direction input:

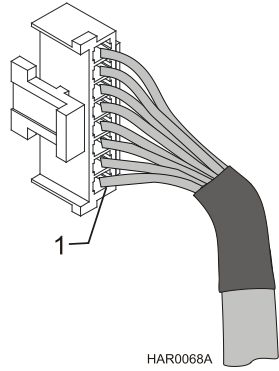
Pin	Signal	Function	Pin Positions
1	SUPRET	Supply return	 <p>HAR0068A</p>
2	+5 V	NA	
3	—	—	
4	—	—	
5	—	—	
6	DIR/CHB	Direction input (push/pull 5 V or open collector)	
7	—	—	
8	PULS/CHA	Pulse input (push/pull 5 V or open collector)	

Table 10: Pulse-and-Direction Auxiliary Encoder Pin Assignments on J2

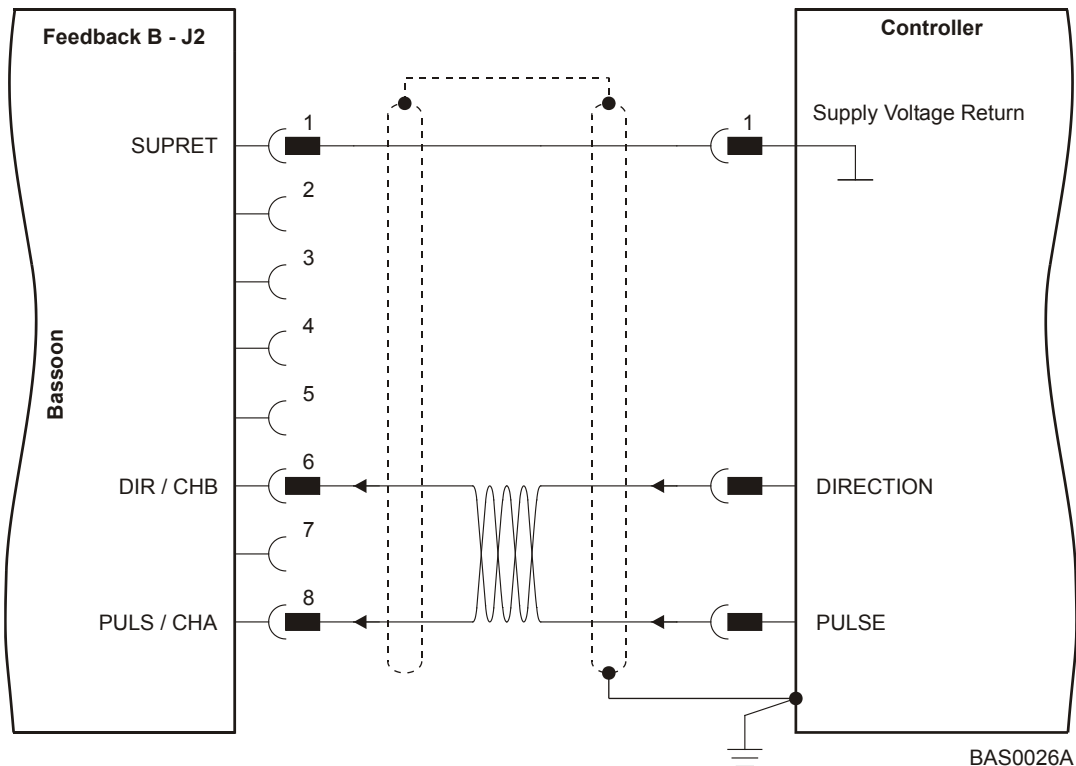


Figure 24: Pulse-and-Direction Auxiliary Encoder Pins on J2 - Connection Diagram

Below are the signals on the Auxiliary Feedback ports when set up to run as a differential pulse-and-direction input:

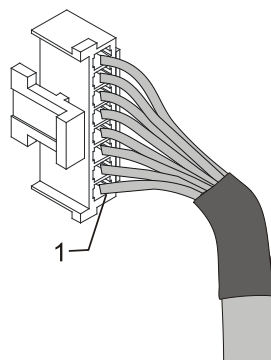
Pin	Signal	Function	Pin Positions
1	SUPRET	Supply return	 <p>HAR0068A</p>
2	+5 V	NA	
3	—	—	
4	—	—	
5	DIR-/CHB-	Direction low input	
6	DIR/CHB	Direction high input	
7	PULS-/CHA-	Pulse low input	
8	PULS/CHA	Pulse high input	

Table 11: Differential Pulse-and-Direction Auxiliary Encoder Pin Assignments on J2

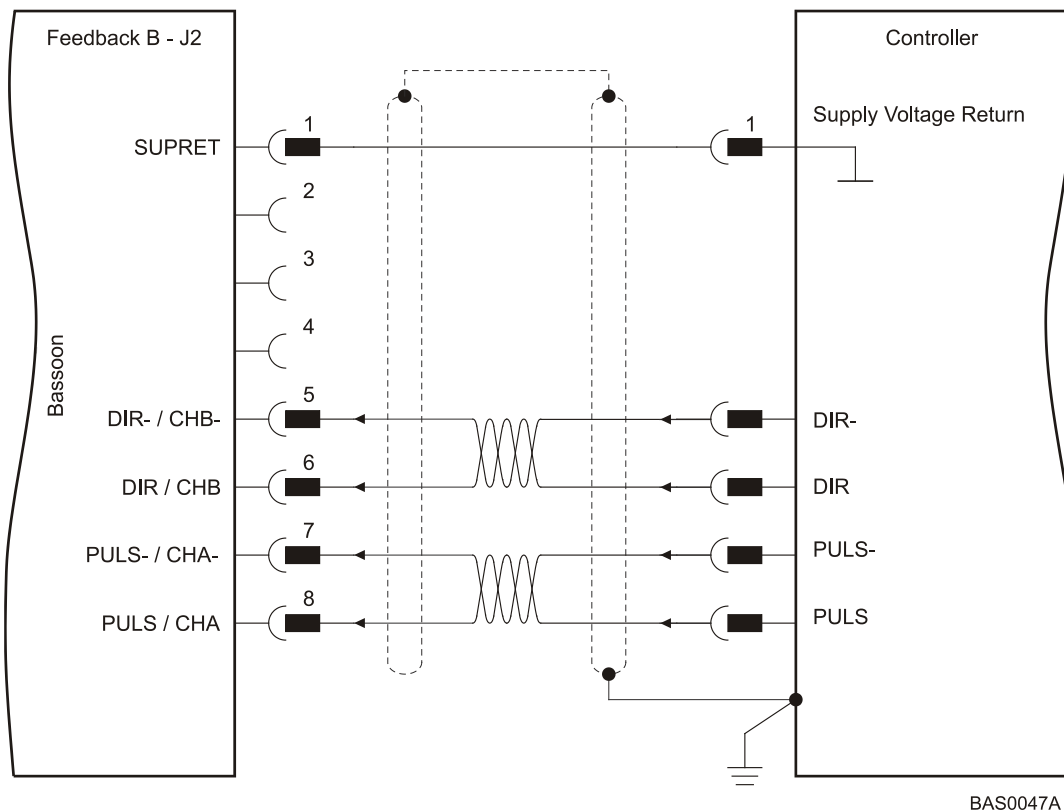


Figure 25: Differential Pulse-and-Direction Auxiliary Encoder Pins on J2 - Connection Diagram

3.5.7. I/O Cables

The following table lists the I/O cables that you should connect according to your specific requirements:

I/O Description	Total	Port
Digital input	6	J5
Digital output	2	J6
Analog input	1	J7

3.5.7.1. Digital Input (Port J5)

Notes for connecting the digital input cable:

- Use 24 or 26 AWG twisted pair shielded cable.
- Connect the cable shield to the ground near the signal source (controller) according to the manufacturer’s recommendations.

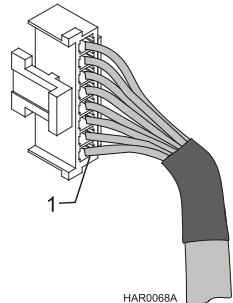
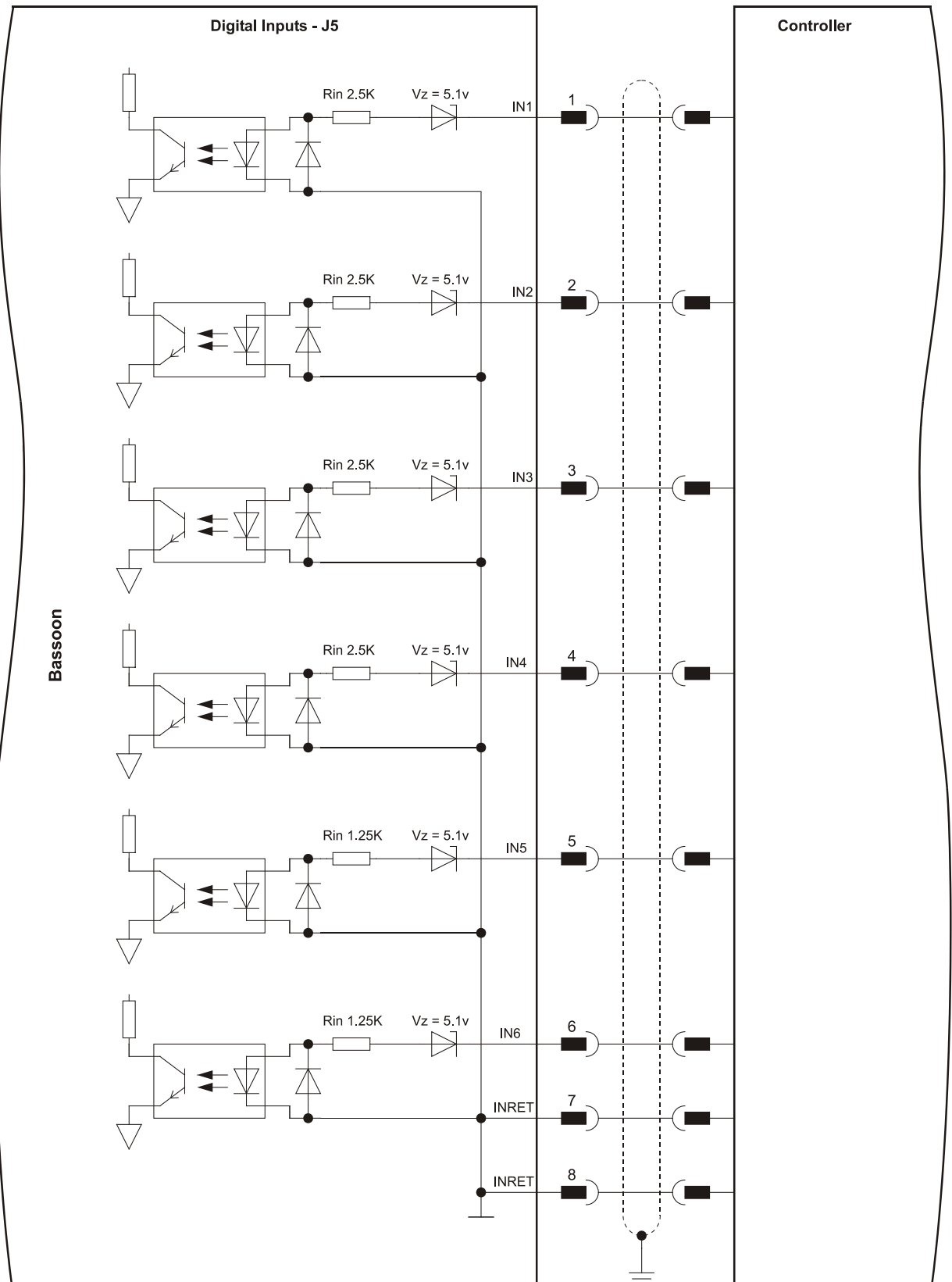
Pin	Signal	Function	Pin Positions
1	IN1	Programmable input 1 (general purpose, RLS, FLS, INH)	
2	IN2	Programmable input 2 (general purpose, RLS, FLS, INH)	
3	IN3	Programmable input 3 (general purpose, RLS, FLS, INH)	
4	IN4	Programmable input 4 (general purpose, RLS, FLS, INH)	
5	IN5	Programmable input 5 (event capture, Main Home, general purpose, RLS, FLS, INH)	
6	IN6	Programmable input 6 (event capture, Auxiliary Home, general purpose, RLS, FLS, INH)	
7	INRET	Programmable input return	
8	INRET	Programmable input return	

Table 12: Digital Input Cable Pin Assignments



BAS0020A

Figure 26: Digital Input Connection Diagram

3.5.7.2. Digital Output (Port J6)

Notes for connecting the digital output cable:

- Use 24 or 26 AWG twisted pair shielded cable.
- Connect the cable shield to the ground near the controller according to the manufacturer’s recommendations.

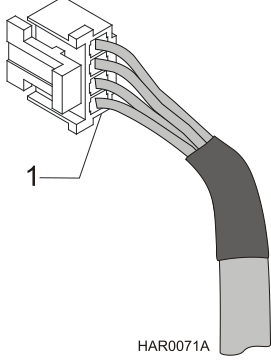
Pin	Signal	Function	Pin Positions
1	OUT1	Programmable output 1	 <p>HAR0071A</p>
2	OUTRET1	Programmable output return 1	
3	OUT2	Programmable output 2	
4	OUTRET2	Programmable output return 2	

Table 13: Digital Output Cable Pin Assignment

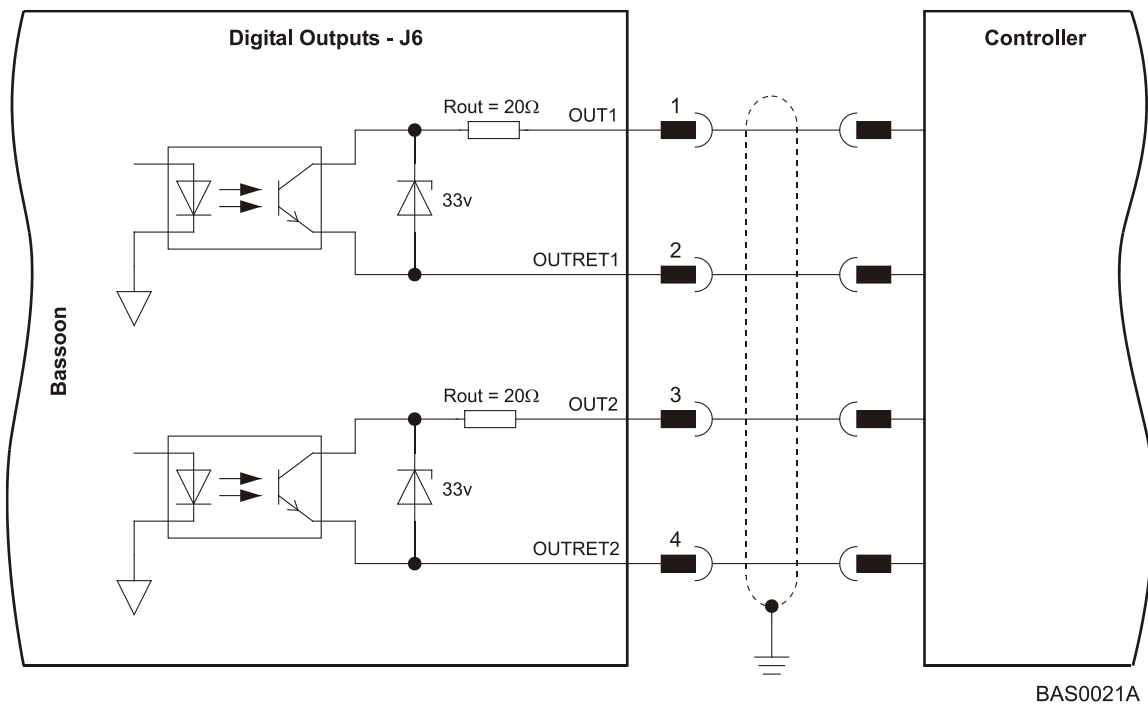


Figure 27: Digital Output Connection Diagram

3.5.7.3. Analog Input (Port J7)

Notes for connecting the analog input cable:

- Use 24, 26 or 28 AWG twisted pair shielded cable.
- Connect the cable shield to the ground near the signal source (controller) according to the manufacturer’s recommendations.

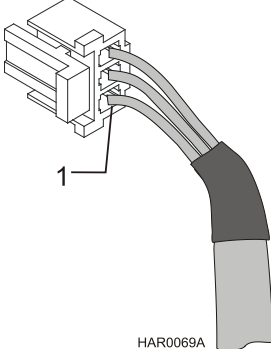
Pin	Signal	Function	Pin Position
1	ANLIN1+	Analog input 1+	 <p>HAR0069A</p>
2	ANLIN1-	Analog input 1-	
3	ANLRET	Analog ground	

Table 14: Analog Input Cable Pin Assignments

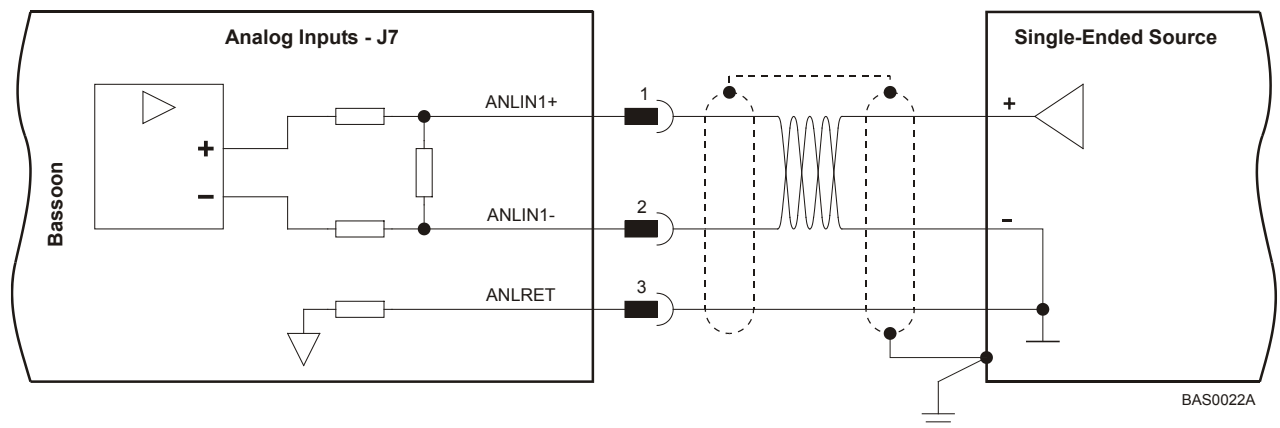


Figure 28: Analog Input with Single-Ended Source

3.5.8. Communication Cable (Port J1, J8, J9)

The communication cables use an 8-pin RJ-45 plug that connects to the J1 port (RS-232), the J8 port (CANopen) and/or J9 (CANopen) on the front of the Bassoon.

The communication interface may differ according to the user’s hardware. The Bassoon can communicate using the following options:

- a. RS-232, full duplex
- b. CANopen
- c. RS-232 and CANopen can be used simultaneously

RS-232 communication requires a standard, commercial 3-core null-modem cable connected from the Bassoon to a serial interface on the PC. The interface is selected and set up in the Composer software.

In order to benefit from **CANopen** communication, the user must have an understanding of the basic programming and timing issues of a CANopen network. The interface is electrically isolated by opto-couplers and isolated power is supplied by the Bassoon.

For ease of setup and diagnostics of CAN communication, RS-232 and CANopen can be used simultaneously.

3.5.8.1. RS-232 Communication

Notes for connecting the RS-232 communication cable (J1 port):

- Use a 26 or 28 AWG twisted pair shielded cable. The cable should have an aluminum foil shield covered by copper braid with a drain wire.
- Connect the shield to the ground of the host (PC). Usually, this connection is soldered internally inside the connector at the PC end. You can use the drain wire or shield to facilitate connection.
- The male RJ plug must have a shield cover.
- Ensure that the shield of the cable is connected to the shield of the RJ plug. The drain wire can be used to facilitate the connection.

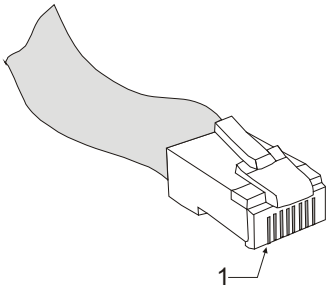
Pin	Signal	Function	Pin Locations
1, 2	N/A	—	
3	Tx	RS-232 transmit	
4	N/A	—	
5	COMRET	Communication return	
6	Rx	RS-232 receive	
7, 8	N/A	—	

Table 15: RS-232 (J1) Cable Pin Assignments

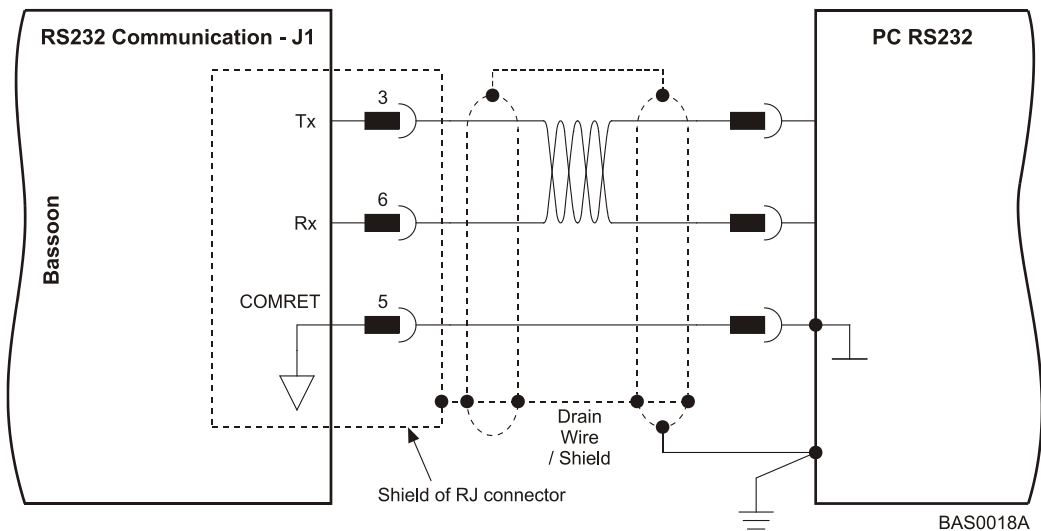


Figure 29: RS-232 Connection Diagram

3.5.8.2. CANopen Communication

Notes for connecting the CANopen communication cable (J8 and/or J9 port):

- Use a 26 or 28 AWG twisted pair shielded cable. The cable should have an aluminum foil shield covered by copper braid with a drain wire.
- Connect the shield to the ground of the host (PC). Usually, this connection is soldered internally inside the connector at the PC end. You can use the drain wire or shield to facilitate connection.
- The male RJ plug must have a shield cover.
- Ensure that the shield of the cable is connected to the shield of the RJ plug. The drain wire can be used to facilitate the connection.
- Connect a termination 120-Ω resistor at each of the two ends of the network cable.

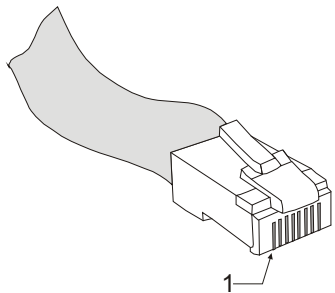
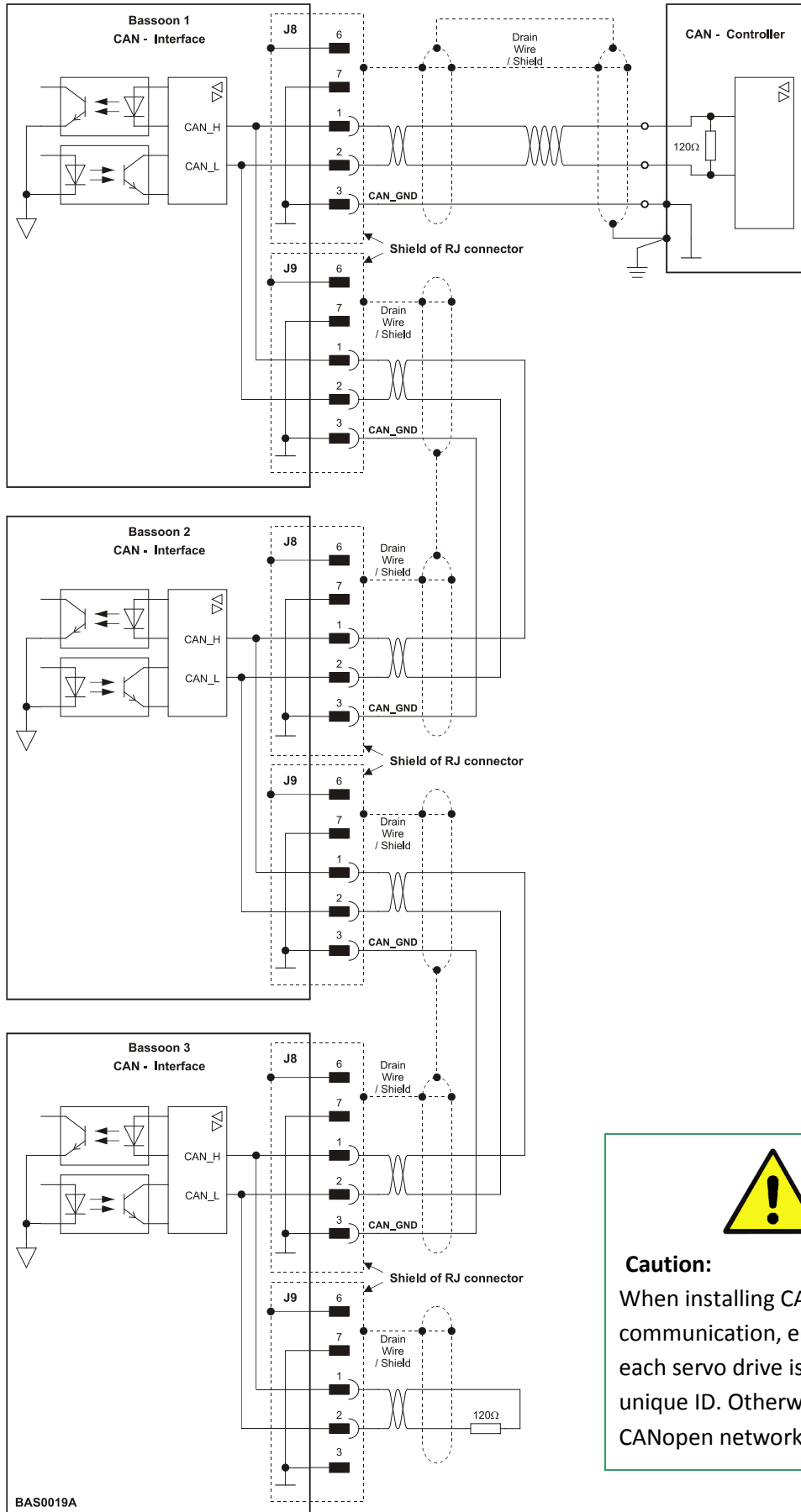
Pin	Signal	Function	Pin Positions
1	CAN_H	CAN_H busline (dominant high)	
2	CAN_L	CAN_L busline (dominant low)	
3	CAN_GND	CAN ground	
4	—	—	
5	—	—	
6	CAN_SHLD	Shield, connected to the RJ plug cover	
7	CAN_GND	CAN ground	
8	—	—	

Table 16: CANopen (J8, J9) Cable Pin Assignments



BAS0019A



Caution:
When installing CANopen communication, ensure that each servo drive is allocated a unique ID. Otherwise, the CANopen network may hang.

Figure 30: CANopen Connection Diagram

3.6. Powering Up

After the Bassoon has been mounted, check that the cables are intact. The Bassoon servo drive is then ready to be powered up.



Caution:

Before applying power, ensure that the AC supply is within the range specified for your specific type of Bassoon.

To power up the system, first switch on the auxiliary power and then the main power supply. (Note that this order is recommended but not critical; if a problem occurs, the system is well protected.) The two-color LED turns green to indicate proper functioning.

3.7. Initializing the System

After the Bassoon has been connected and mounted, the system must be set up and initialized. This is accomplished using the *Composer*, Elmo's Windows-based software application. Install the application and then perform setup and initialization according to the directions in the *Composer Software Manual*.

Chapter 4: Technical Specifications

This chapter provides detailed technical information regarding the Bassoon. This includes its dimensions, power ratings, the environmental conditions under which it can be used, the standards to which it complies and other specifications.

4.1. Features

The Bassoon's features determine how it controls motion, as well as how it processes host commands, feedback and other input.

4.1.1. Motion Control Modes

- Current/Torque - up to 14 kHz sampling rate
- Velocity - up to 7 kHz sampling rate
- Position - up to 3.5 kHz sampling rate

4.1.2. Advanced Positioning Motion Control Modes

- PTP, PT, PVT, ECAM, Follower, Pulse and Direction, Dual Loop
- Fast event capturing inputs
- Fast output compare (OC)

4.1.3. Advanced Filters and Gain Scheduling

- “On-the-Fly” gain scheduling of current and velocity
- Velocity and position with “1-2-4” PIP controllers.
- Automatic commutation alignment
- Automatic motor phase sequencing

4.1.4. Fully Programmable

- Third generation programming structure with motion commands
- Event capturing interrupts
- Event triggered programming

4.1.5. Feedback Options

- Incremental Encoder – up to 20 Mega-Counts (5 Mega-Pulse) per second
- Digital Halls – up to 2 kHz
- Incremental Encoder with Digital Halls for commutation – up to 20 Mega-Counts per second for encoder
- Absolute Encoder
- Interpolated Analog (Sine/Cosine) Encoder – up to 250 kHz (analog signal)
 - Internal Interpolation - up to X4096
 - Automatic Correction of amplitude mismatch, phases mismatch, signals offset
 - Encoder outputs, buffered, differential
- Resolver
 - Programmable 10 to 15 bit resolution
 - Up to 512 revolutions per second (RPS)
 - Encoder outputs, buffered, differential
- Elmo drives provide supply voltage for all the feedback options

4.1.6. Input/Output

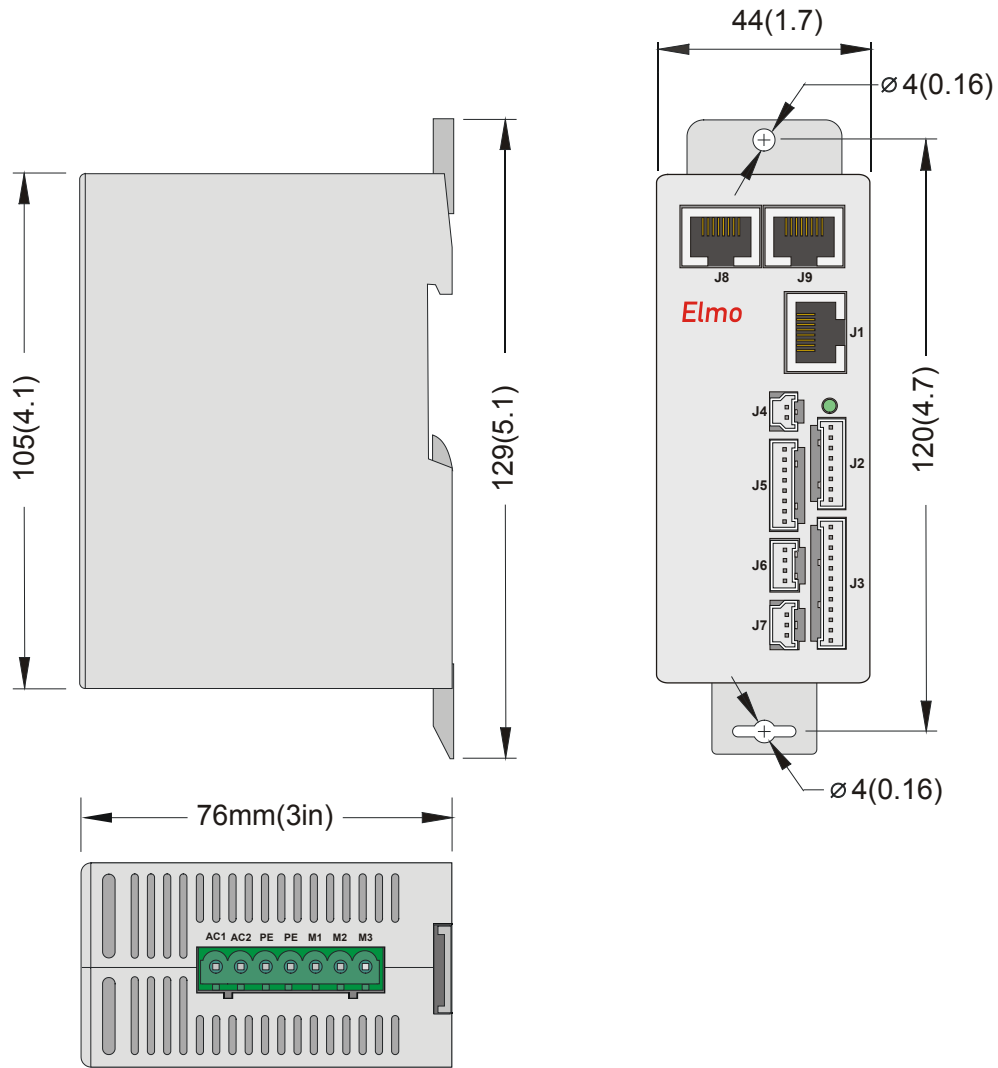
- Analog Inputs with up to 14-bit resolution
- Programmable digital inputs, optically isolated
 - Inhibit/Enable motion
 - Software and analog reference stop
 - Motion limit switches
 - Begin on input
 - Abort motion
 - General-purpose
 - Homing
- Fast event capture inputs, optically isolated
- Programmable digital outputs
 - Brake Control
 - Amplifier fault indication
 - General-purpose
 - Servo enable indication
- Buffered and differential outputs of the main encoder with up to 5 MHz pulses
- Emulated output of the resolver or interpolated analog encoder
- Fast output compare (OC), optically isolated

4.1.7. Built-In Protection

- Software error handling
- Abort (hard stops and soft stops)
- Status reporting
- Protection against
 - Shorts between motor power outputs
 - Shorts between motor power outputs and power input/return
 - Failure of internal power supplies
 - Overheating
 - Over/Under voltage
 - Loss of feedback
 - Following error
 - Current limits

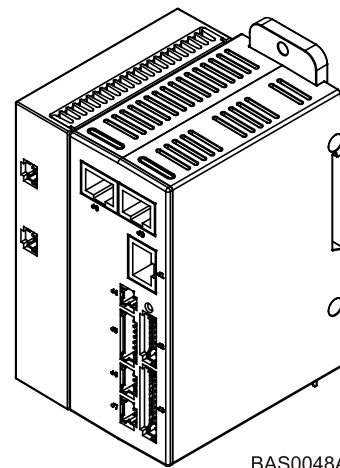
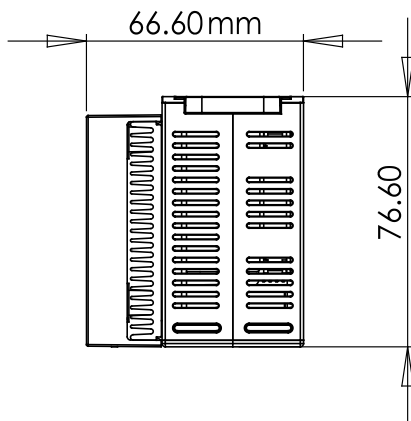
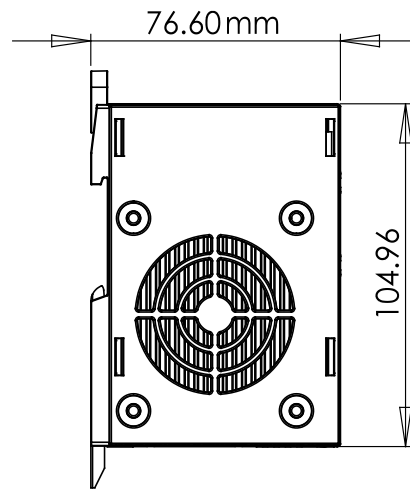
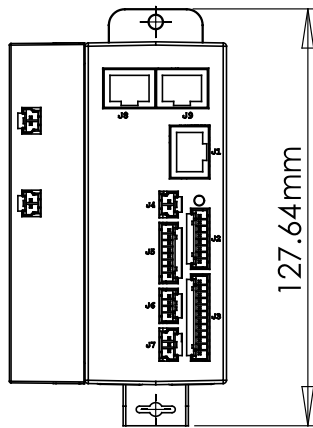
4.2. Bassoon Dimensions

4.2.1. Bassoon without a Fan



BAS0003A

4.2.2. Bassoon with a Fan



BAS0048A

Feature	Units	1/230	3/230	5/230	6/230	9/230	6/230-18P
Minimum supply voltage	VAC	30					
Nominal supply voltage	VAC	230					
Maximum supply voltage	VAC	270					
Maximum continuous power output	W	320	1050	1600	1900	2900	1900
Efficiency at rated power (at nominal conditions)	%	>97					
Auxiliary supply voltage	VDC	24 ± 20%					
Auxiliary power supply	VA	8					
Amplitude sinusoidal/DC continuous current	A	1	3.3	5	6	9	6
Sinusoidal continuous RMS current limit (Ic)	A	0.7	2.3	3.5	4.2	6.4	4.2
Peak current limit	A	2 x Ic					3 x Ic
Supplied with heat sink		No	#2 (fins)	#4 (fins and fan)			
Built-in shunt (peak power)	W	400					
Weight	g (oz)	350 g (12.35)	490 g (17.28)	505 g (17.81)			
Dimensions	mm (in)	105 x 44 x 76 (4.13" x 1.73" x 3")	105 x 56 x 76 (4.13" x 2.20" x 3")	105 x 66.5 x 76 (4.13" x 2.60" x 3")			
Digital in/Digital out/Analog in		6/2/1					
Mounting method		Wall mount (Bookshelf) or DIN rail					



4.3. Environmental Conditions

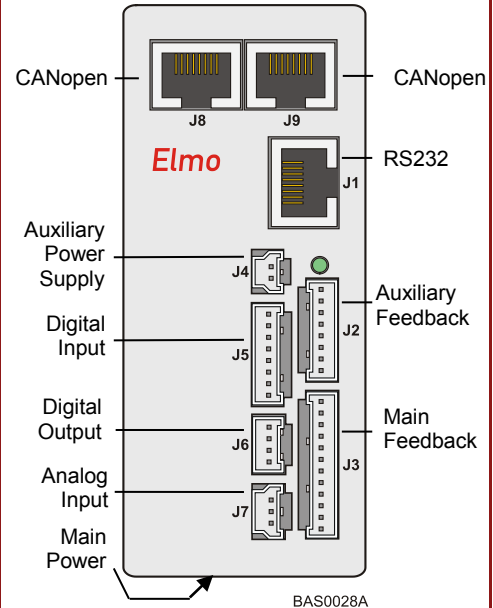
Feature	Details
Operating ambient temperature according to IEC60068-2-2	0 °C to 40 °C (32 °F to 104 °F)
Storage temperature	-20 °C to +85 °C (-4 °F to +185 °F)
Maximum non-condensing humidity according to IEC60068-2-78	95%
Maximum Operating Altitude	2,000 m (6562 feet)
Mechanical Shock according to IEC60068-2-27	15g / 11ms Half Sine
Vibration according to IEC60068-2-6	5 Hz ≤ f ≤ 10 Hz: ±10mm 10 Hz ≤ f ≤ 57 Hz: 4G 57 Hz ≤ f ≤ 500 Hz:5G

4.4. Bassoon Connectors

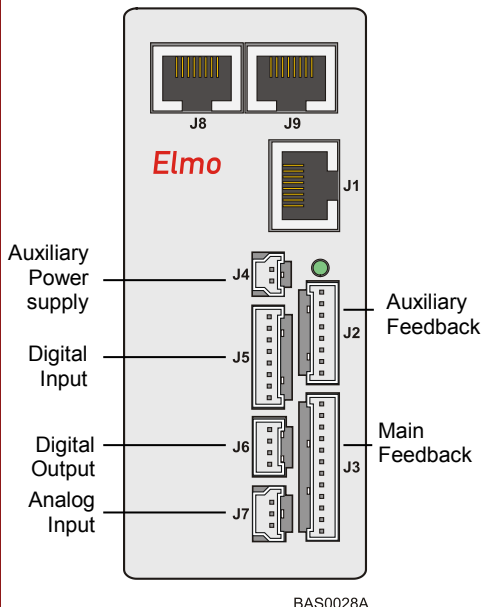
The following connectors are used for wiring the Bassoon.

4.4.1. Connector Types

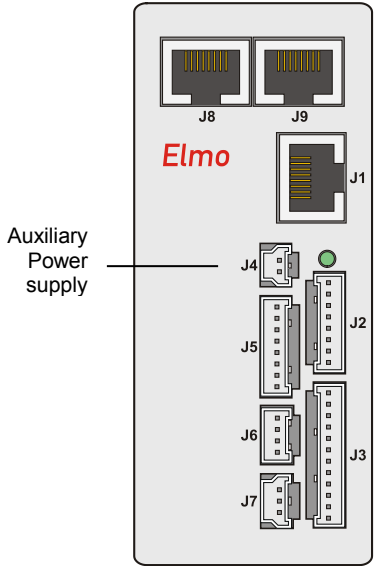
The table below shows the connector panel of the Bassoon.

Pins	Type	Connector Maker & No. / Mating Plug (on Cable)	Port	Connector Location
8	RJ-45	RJ-45 jack mates with RJ-45 plug	J1, J8, J9	
8	2 mm Pitch	Molex 35363-0800 mates with 35507-0800	J2, J5	
12	2 mm Pitch	Molex 35363-1200 mates with 35507-1200	J3	
2	2 mm Pitch	Molex 35363-0200 mates with 35507-0200	J4	
4	2 mm Pitch	Molex 35363-0400 mates with 35507-0400	J6	
3	2 mm Pitch	Molex 35363-0300 mates with 35507-0300	J7	
7	5.08 mm Pitch Terminal Block	Phoenix MSTBA 2.5/7-G-5.08 with MSTB 2.5/7-ST-5.08	power	

4.4.2. Control and Feedback Connector Specifications

Feature	Details	Connector Location
Product name	Sherlock	
Manufacturer	Molex	
Wire size	24, 26, 28, 30 AWG	
Maximum current	2 A	
Temperature range	-40° to 105° C (-40° to 221° F)	
Plating contact	Tin/Lead (Sn/Pb)	
Maximum voltage	125 V	
Contact resistance	< 20 mΩ	
Withstanding voltage	500 VAC	
Insulation resistance	> 1000 MΩ	
Terminal contact	Phosphor bronze	
UL files	E29179, UL 94 V-0	
Cable connector	Molex 35507-XX00, where XX is the number of leads	
Hand crimper	Molex 63811-1200	
Crimp terminal	Molex 50212	

4.5. Auxiliary Power Supply (J4)

Feature	Details	Connector Location
Auxiliary power supply	DC source only	 <p style="text-align: right;">BAS0028A</p>
Auxiliary supply input voltage	24 V ±20%	
Auxiliary supply input power	8 VA (maximum)	

4.6. Control Specifications

4.6.1. Current Loop

Feature	Details
Controller type	Vector, digital
Compensation for bus voltage variations	On-the-fly automatic gain scheduling
Motor types	<ul style="list-style-type: none"> • AC brushless (sinusoidal) • DC brushless (trapezoidal) • DC brush • Linear Motors • Moving coils
Current control	<ul style="list-style-type: none"> • Fully digital • Sinusoidal with vector control • Programmable PI control filter based on a pair of PI controls of AC current signals and constant power at high speed
Current loop bandwidth	<2.5 kHz
Current sampling time	Programmable 70 to 100 μsec
Current sampling rate	Up to 16 kHz; default 11 kHz

4.6.2. Velocity Loop

Feature	Details
Controller type	PI
Velocity control	<ul style="list-style-type: none"> Fully digital Programmable PI and FFW control filters On-the-fly gain scheduling Automatic, manual and advanced manual tuning
Velocity and position feedback options	<ul style="list-style-type: none"> Incremental Encoder Digital Halls Interpolated Analog (Sine/Cosine) Encoder (optional) Resolver (optional) <p>Note: With all feedback options, 1/T with automatic mode switching is activated (gap, frequency and derivative).</p>
Velocity command options	<ul style="list-style-type: none"> Analog Internally calculated by either jogging or step <p>Note: All software-calculated profiles support on-the-fly changes.</p>
Velocity loop bandwidth	<350 Hz
Velocity sampling time	140 to 200 μ sec (x2 current loop sample time)
Velocity sampling rate	Up to 8 kHz; default 5.5 kHz

4.6.3. Position Loop

Feature	Details
Controller type	"1-2-4" PIP
Position command options	<ul style="list-style-type: none"> Software Pulse and Direction
Position loop bandwidth	<80 Hz
Position sampling time	280 to 400 μ sec (x 4 current loop sample time)
Position sampling rate	Up to 4 kHz; default 2.75 kHz

4.7. Feedback

The Bassoon can receive and process feedback input from diverse types of devices.

4.7.1. Feedback Supply Voltage

Feature	Details
J3 (main encoder) supply voltage	5 V \pm 5% @ 200 mA maximum
J2 (auxiliary encoder) supply voltage	5 V \pm 5% @ 200 mA maximum

4.7.2. Incremental Encoder

Feature	Details
Encoder format	<ul style="list-style-type: none"> • A, B and Index • Differential • Quadrature
Interface:	RS-422
Input resistance:	Differential: 120 Ω
Maximum incremental encoder frequency:	Maximum absolute: 5 MHz pulses
Minimum quadrature input period (P_{IN})	112 nsec
Minimum quadrature input high/low period (P_{HL})	56 nsec
Minimum quadrature phase period (P_{PH})	28 nsec
Maximum encoder input voltage range	Common mode: \pm 7 V Differential mode: \pm 7 V

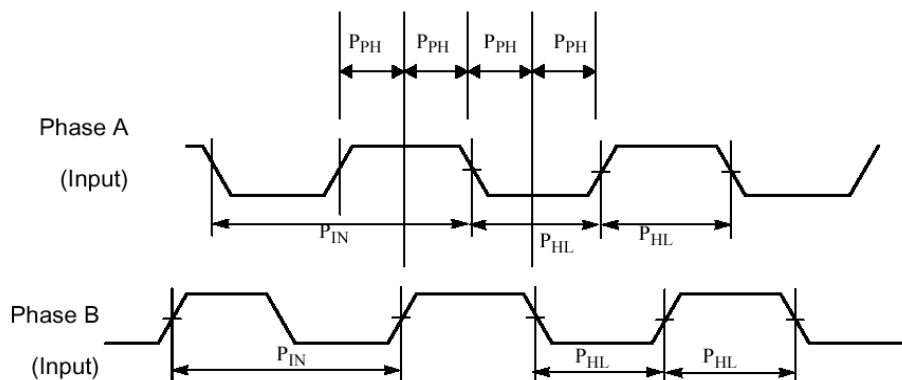


Figure 31: Encoder Phase Diagram

4.7.3. Digital Halls

Feature	Details
Halls inputs	<ul style="list-style-type: none"> • H_A, H_B, H_C. • Single ended inputs • Built in hysteresis for noise immunity.
Input voltage	Nominal operating range: $0\text{ V} < V_{\text{In_Hall}} < 5\text{ V}$ Maximum absolute: $-1\text{ V} < V_{\text{In_Hall}} < 15\text{ V}$ High level input voltage: $V_{\text{InHigh}} > 2.5\text{ V}$ Low level input voltage: $V_{\text{InLow}} < 1\text{ V}$
Input current	Sink current (when input pulled to the common): 3 mA Source current: 1.5 mA (designed to also support open collector Halls)
Maximum frequency	$f_{\text{MAX}} : 2\text{ kHz}$

4.7.4. Interpolated Analog (Sine/Cosine) Encoder

Feature	Details
Analog encoder format	Sine and Cosine signals
Analog input signal level	Offset voltage: 2.2 V to 2.8 V Differential, 1 V peak to peak
Input resistance	Differential 120 Ω
Maximum analog signal frequency	$f_{\text{MAX}} : 250\text{ kHz}$
Interpolation multipliers	Programmable: x4 to x4096
Maximum “counts” frequency	80 mega-counts/sec “internally”
Automatic error correction	Signals amplitude mismatch Signals phase shift Signals offset

4.7.5. Resolver

Feature	Details
Resolver format	<ul style="list-style-type: none"> • Sine/Cosine • Differential
Input resistance	Differential 2.49 kΩ
Resolution	Programmable: 10 to 15 bits
Maximum electrical frequency (RPS)	512 revolutions/sec
Resolver transfer ratio	0.5
Reference frequency	1/Ts (Ts = sample time in seconds)
Reference voltage	Supplied by the Bassoon
Reference current	up to ±50 mA

4.7.6. Tachometer*

Feature	Details
Tachometer format	Differential
Maximum operating differential voltage for TAC1+, TAC1-	±20 V
Maximum absolute differential input voltage for TAC1+, TAC1-	±25 V
Maximum operating differential voltage for TAC2+, TAC2-	±50 V
Maximum absolute differential input voltage for TAC2+, TAC2-	±60 V
Input resistance for TAC1+, TAC1-	46 kΩ
Input resistance for TAC2+, TAC2-	100 kΩ
Resolution	14 bit

* Only one Tachometer port can be used at a time (either TAC1+/TAC1- or TAC2+/TAC2-).

TAC1+/TAC1- is used in applications with having a Tachometer of less than 20 V.

TAC2+/TAC2- is used in applications with having a Tachometer of between 20 V and 50 V.

4.7.7. Potentiometer

Feature	Details
Potentiometer Format	Single-ended
Operating Voltage Range	0 to 5 V supplied by the Bassoon
Potentiometer Resistance	100 Ω to 1 k Ω ... above this range, linearity is affected detrimentally
Input Resistance	100 k Ω
Resolution	14 Bit

4.7.8. Encoder Outputs

Feature	Details
Encoder output format:	<ul style="list-style-type: none"> • A, B, Index • Differential outputs • Quadrature
Interface	RS-422
Output current capability	<ul style="list-style-type: none"> • Driving differential loads of 200 Ω
Available at options	<ul style="list-style-type: none"> • Buffered outputs of main-input incremental encoder • Emulated encoder outputs of analog encoder • Emulated encoder outputs of the resolver
Maximum frequency	f_{MAX} : 5 MHz pulses/output
Index (marker):	Length of pulse is one quadrature (one quarter of an encoder cycle) and synchronized to A&B

4.8. I/Os

The Bassoon has:

- 6 Digital Inputs
- 2 Digital Outputs
- 1 Analog Input

4.8.1. Digital Input Interfaces

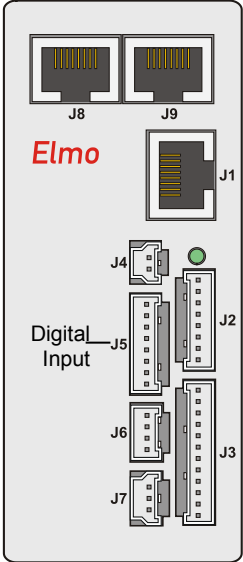
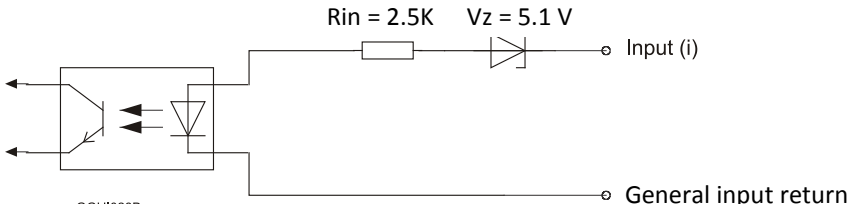
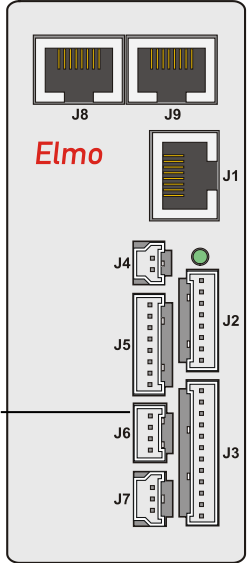
Feature	Details	Connector Location
Type of input	<ul style="list-style-type: none"> • Optically isolated • Single ended • PLC level 	 <p style="text-align: right;">BAS0028A</p>
Input current	$I_{in} = \frac{V_{in} - 6.5V}{2500\Omega}$ <p>* $I_{in} = 2.2 \text{ mA @ } V_{in} = 12 \text{ V}$</p>	
Input current for high speed inputs	$I_{in} = \frac{V_{in} - 6.5V}{1250\Omega}$ <p>* $I_{in} = 4.4 \text{ mA @ } V_{in} = 12 \text{ V}$</p>	
High-level input voltage	12 V < V_{in} < 30 V, 24 V typical	
Low-level input voltage	0 V < V_{in} < 6.5 V	
Minimum pulse width	> 4 x TS, where TS is sampling time	
Execution time (all inputs): the time from application of voltage on input until execution is complete	<p>If input is set to one of the built-in functions — Home, Inhibit, Hard Stop, Soft Stop, Hard and Soft Stop, Forward Limit, Reverse Limit or Begin — execution is immediate upon detection: $0 < T < 4 \times T$</p> <p>If input is set to General input, execution depends on program. Typical execution time: $\cong 0.5 \text{ msec.}$</p>	
High-speed inputs - minimum pulse width, in high-speed mode	<p>$T < 5 \mu\text{sec}$</p> <p>Notes:</p> <ul style="list-style-type: none"> • Home mode is high-speed mode and can be used for fast capture and precise homing. • High speed input has a digital filter set to same value as digital filter (EF) of main encoder. • Highest speed is achieved when turning on optocouplers. 	
		

Figure 32: Digital Input Schematic

4.8.2. Digital Output Interface

Feature	Details	Connector Location
Type of output	<ul style="list-style-type: none"> • Optically isolated • Open collector and open emitter 	
Maximum supply output (Vcc)	30 V	
Maximum output current Io (max) (Vout = Low)	$I_{out} (max) \leq 10 \text{ mA}$	
VOL @ maximum output voltage (low level)	$V_{out} (on) \leq 0.3 \text{ V} + 0.02 * I_{out} (10 \text{ mA})$	
RL	<p>External resistor RL must be selected to limit output current to no more than 10 mA.</p> $R_L = \frac{V_{cc} - VOL}{I_o(max)}$	
Executable time	<p>If output is set to one of the built-in functions — Home flag, Brake or AOK — execution is immediate upon detection: $0 < T < 4 \times TS$</p> <p>If output is set to General output and is executed from a program, the typical time is approximately 0.5 msec.</p>	

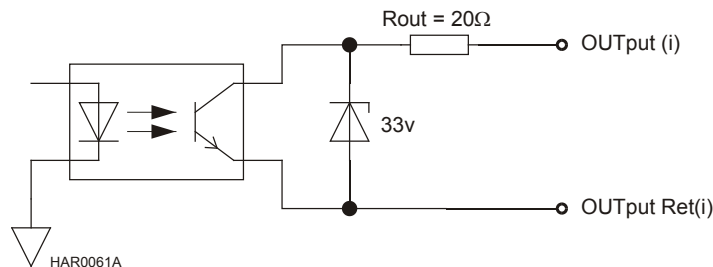
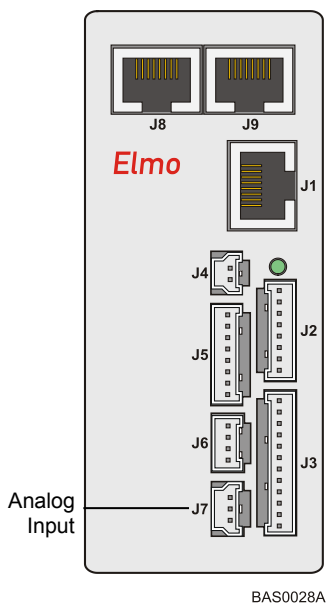
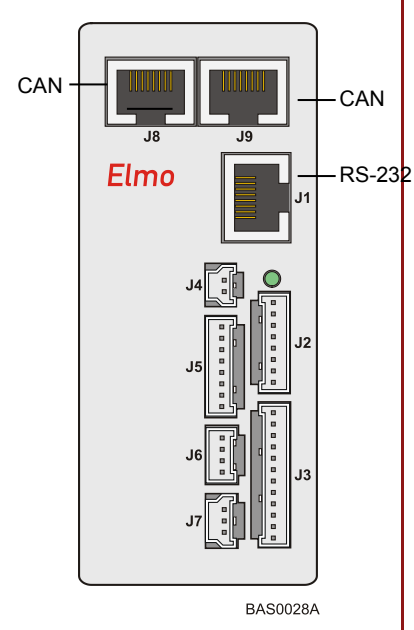


Figure 33: Digital Output Schematic

4.8.3. Analog Input (J7)

Feature	Details	Connector Location
Maximum operating differential mode voltage	±10 V	
Maximum absolute differential input voltage	±16 V	
Differential input resistance	3 kΩ	
Analog input command resolution	14-bit inputs	

4.9. Communications

Specification	Details	Connector Location
RS-232	<p>Signals:</p> <ul style="list-style-type: none"> • RxD , TxD , Gnd • Full duplex, serial communication for setup and control. • Baud Rate of 9,600 to 115,200 bits/sec. 	
CAN	<p>CAN bus Signals:</p> <ul style="list-style-type: none"> • CAN_H, CAN_L, CAN_GND • Maximum Baud Rate of 1 Mbits/sec. <p>Version:</p> <ul style="list-style-type: none"> • DS 301 V4.01 <p>Device Profile (drive and motion control):</p> <ul style="list-style-type: none"> • DS 402 	

4.10. Pulse-Width Modulation (PWM)

Feature	Details
PWM resolution	12-bit
PWM switching frequency on the load	2/ Ts (factory default 22 kHz on the motor)

4.11. Heat Sink Specifications

The following table indicates the RMS output power when operating the Bassoon at nominal DC bus voltage:

Bassoon	1/230	3/230	6/230
RMS output power without heat sink (%)	80	40	20

If the input voltage is lower, the RMS output current without a heatsink is higher.

Two types of heat sinks are recommended for ensuring maximum continuous output power of the drive:

- Finned heat sink
- L-Shaped heat sink

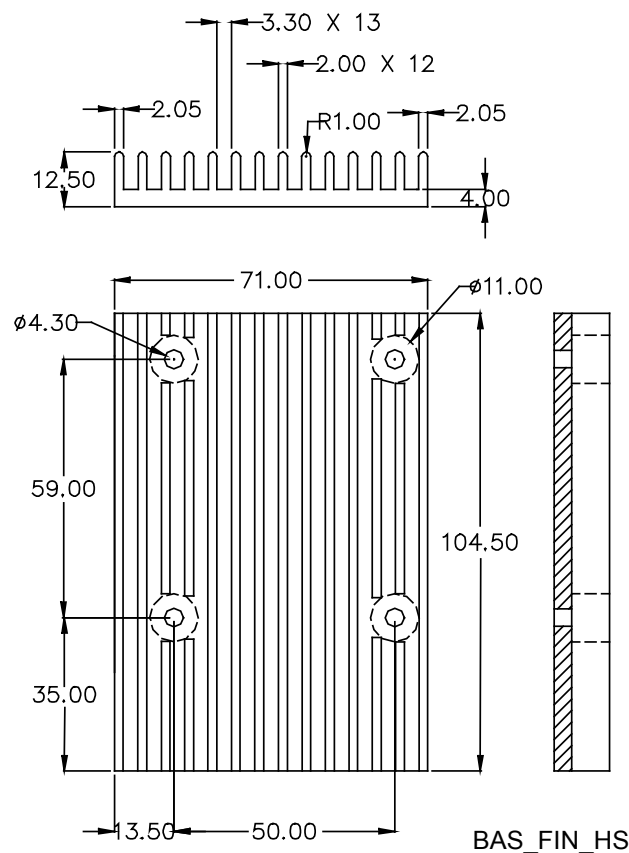


Figure 34: Fin-Type Heat Sink Dimensions

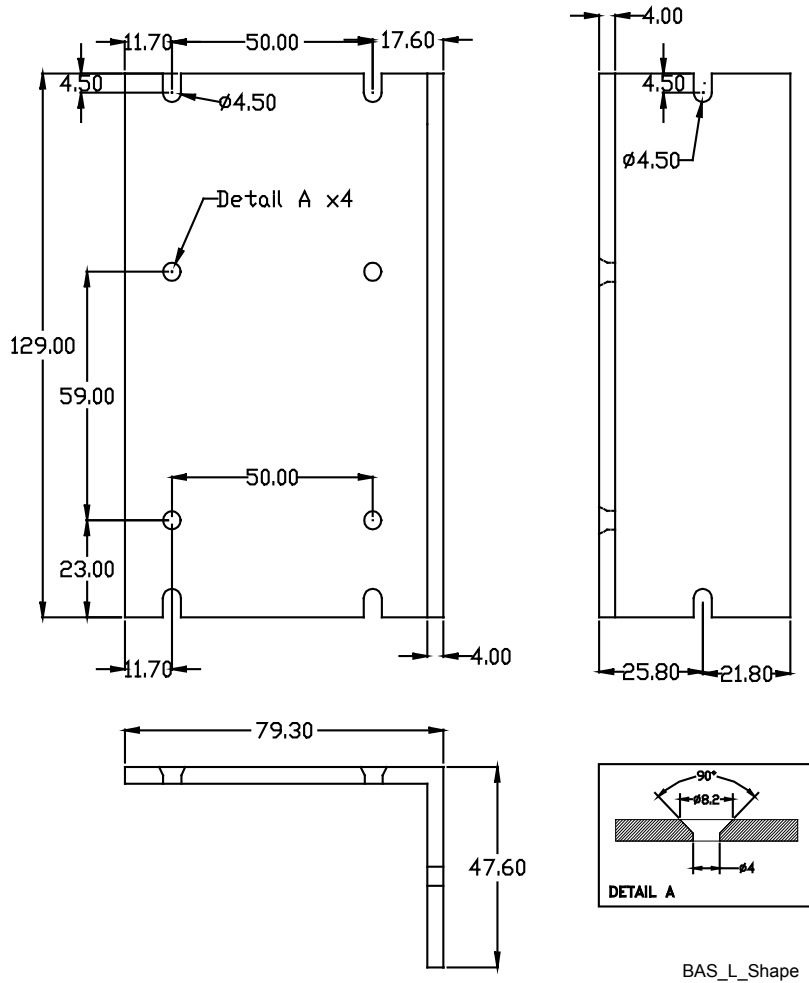


Figure 35: L-Shaped Heat Sink Dimensions

4.12. Compliance with Standards

Specification	Details
Quality Assurance	
ISO 9001:2008	Quality Management
Design	
Approved IEC/EN 61800-5-1, Safety	Printed wiring for electronic equipment (clearance, creepage, spacing, conductors sizing, etc.)
MIL-HDBK- 217F	Reliability prediction of electronic equipment (rating, de-rating, stress, etc.)
<ul style="list-style-type: none"> • UL 60950 • IPC-D-275 • IPC-SM-782 • IPC-CM-770 • UL 508C • UL 840 	Printed wiring for electronic equipment (clearance, creepage, spacing, conductors sizing, etc.)
In compliance with VDE0160-7 (IEC 68)	Type testing
Safety	
Recognized UL 508C	Power Conversion Equipment
In compliance with UL 840	Insulation Coordination Including Clearances and Creepage Distances for Electrical Equipment
In compliance with UL 60950	Safety of Information Technology Equipment Including Electrical Business Equipment
Approved IEC/EN 61800-5-1, Safety	Adjustable speed electrical power drive systems
In compliance with EN 60204-1	Low Voltage Directive 73/23/EEC



Specification	Details
EMC	
Approved IEC/EN 61800-3, EMC	Adjustable speed electrical power drive systems
In compliance with EN 55011 Class A with EN 61000-6-2 : Immunity for industrial environment, according to: IEC 61000-4-2 / criteria B IEC 61000-4-3 / criteria A IEC 61000-4-4 / criteria B IEC 61000-4-5 / criteria B IEC 61000-4-6 / criteria A IEC 61000-4-8 / criteria A IEC 61000-4-11 / criteria B/C	Electromagnetic compatibility (EMC)
Workmanship	
In compliance with IPC-A-610 , level 3	Acceptability of electronic assemblies
PCB	
In compliance with IPC-A-600 , level 2	Acceptability of printed circuit boards
Packing	
In compliance with EN 100015	Protection of electrostatic sensitive devices
Environmental	
In compliance with 2002/96/EC	Waste Electrical and Electronic Equipment regulations (WEEE) Note: Out-of-service Elmo drives should be sent to the nearest Elmo sales office.
In compliance with 2002/95/EC (effective July 2006)	Restrictions on Application of Hazardous Substances in Electric and Electronic Equipment (RoHS)