

Copley Motion Library

Generated by Doxygen 1.8.6

Thu Mar 12 2015 16:19:51

Contents

1	Copley Motion Library	1
1.1	Introduction	1
1.1.1	Supported platforms	1
1.1.2	Multi-tasking support	1
1.1.3	CAN hardware support	2
1.1.4	EtherCAT hardware support	2
1.2	CANopen basics	2
1.2.1	CANopen Object Dictionary	2
1.2.2	SDO	3
1.2.3	PDO	3
1.2.4	Network management	4
1.2.5	SYNC messages	5
1.2.6	Emergency messages	5
1.3	EtherCAT basics	5
1.4	Architectural overview	5
1.4.1	CanInterface	5
1.4.2	EtherCatHardware	6
1.4.3	Network class	6
1.4.4	CanOpen class	6
1.4.5	EtherCAT class	6
1.4.6	Receiver class	6
1.4.7	Node class	6
1.4.8	Amp class	7
2	Hierarchical Index	9
2.1	Class Hierarchy	9
3	Class Index	13
3.1	Class List	13

4	File Index	19
4.1	File List	19
5	Class Documentation	23
5.1	IOModule::AlgInPDO Class Reference	23
5.1.1	Detailed Description	24
5.1.2	Member Function Documentation	24
5.1.2.1	GetInVal	24
5.1.2.2	Init	25
5.1.2.3	Received	25
5.2	AlgoPhaseInit Struct Reference	25
5.2.1	Detailed Description	26
5.2.2	Constructor & Destructor Documentation	26
5.2.2.1	AlgoPhaseInit	26
5.2.3	Member Data Documentation	26
5.2.3.1	phaseInitConfig	26
5.3	IOModule::AlgOutPDO Class Reference	26
5.3.1	Detailed Description	28
5.3.2	Member Function Documentation	28
5.3.2.1	Init	28
5.3.2.2	Transmit	28
5.3.2.3	Update	28
5.4	Amp Class Reference	29
5.4.1	Detailed Description	43
5.4.2	Constructor & Destructor Documentation	43
5.4.2.1	Amp	43
5.4.2.2	Amp	43
5.4.2.3	Amp	44
5.4.3	Member Function Documentation	45
5.4.3.1	AccLoad2User	45
5.4.3.2	AccMtr2User	45
5.4.3.3	AccUser2Load	45
5.4.3.4	AccUser2Mtr	47
5.4.3.5	CheckStateForMove	47
5.4.3.6	ClearEventLatch	47
5.4.3.7	ClearFaults	47
5.4.3.8	ClearNodeGuardEvent	48

5.4.3.9	Disable	48
5.4.3.10	Dnld16	48
5.4.3.11	Dnld16	49
5.4.3.12	Dnld32	49
5.4.3.13	Dnld32	49
5.4.3.14	Dnld8	50
5.4.3.15	Dnld8	50
5.4.3.16	DnldString	50
5.4.3.17	DoMove	50
5.4.3.18	DoMove	51
5.4.3.19	DoMove	51
5.4.3.20	DoMove	51
5.4.3.21	Download	52
5.4.3.22	Enable	52
5.4.3.23	FormatPosInit	52
5.4.3.24	FormatPtSeg	53
5.4.3.25	FormatPvtSeg	53
5.4.3.26	GetAlgoPhaseInit	53
5.4.3.27	GetAmpConfig	53
5.4.3.28	GetAmpInfo	54
5.4.3.29	GetAmpMode	54
5.4.3.30	GetAmpName	54
5.4.3.31	GetAmpTemp	54
5.4.3.32	GetAnalogCommandFilter	55
5.4.3.33	GetAnalogEncoder	55
5.4.3.34	GetAnalogRefConfig	55
5.4.3.35	GetCammingConfig	55
5.4.3.36	GetCanNetworkConfig	56
5.4.3.37	GetControlWord	56
5.4.3.38	GetCountsPerUnit	56
5.4.3.39	GetCountsPerUnit	57
5.4.3.40	GetCrntLoopConfig	57
5.4.3.41	GetCurrentActual	57
5.4.3.42	GetCurrentCommand	57
5.4.3.43	GetCurrentLimited	59
5.4.3.44	GetCurrentProgrammed	59
5.4.3.45	GetDAConverterConfig	59

5.4.3.46	GetErrorStatus	60
5.4.3.47	GetEventLatch	61
5.4.3.48	GetEventMask	61
5.4.3.49	GetEventStatus	61
5.4.3.50	GetEventSticky	62
5.4.3.51	GetFaultMask	62
5.4.3.52	GetFaults	62
5.4.3.53	GetFuncGenConfig	62
5.4.3.54	GetGainScheduling	63
5.4.3.55	GetHallState	63
5.4.3.56	GetHaltMode	63
5.4.3.57	GetHighVoltage	63
5.4.3.58	GetHomeAccel	64
5.4.3.59	GetHomeAdjustment	64
5.4.3.60	GetHomeCapture	64
5.4.3.61	GetHomeConfig	64
5.4.3.62	GetHomeCurrent	65
5.4.3.63	GetHomeDelay	65
5.4.3.64	GetHomeMethod	65
5.4.3.65	GetHomeOffset	65
5.4.3.66	GetHomeVelFast	66
5.4.3.67	GetHomeVelSlow	66
5.4.3.68	GetloopCommandFilter	66
5.4.3.69	GetloopCommandFilter2	66
5.4.3.70	GetIndexCapture	67
5.4.3.71	GetInputConfig	67
5.4.3.72	GetInputConfig	67
5.4.3.73	GetInputDebounce	68
5.4.3.74	GetInputs	68
5.4.3.75	GetInputs32	68
5.4.3.76	GetInputShapingFilter	69
5.4.3.77	GetloConfig	69
5.4.3.78	GetLOOptions	69
5.4.3.79	GetloPullup	69
5.4.3.80	GetloPullup32	71
5.4.3.81	GetLinkage	71
5.4.3.82	GetLinkRef	71

5.4.3.83	GetMicrostepRate	71
5.4.3.84	GetMotorCurrent	72
5.4.3.85	GetMtrInfo	72
5.4.3.86	GetNetworkOptions	72
5.4.3.87	GetNetworkRef	72
5.4.3.88	GetOutputConfig	73
5.4.3.89	GetOutputConfig	74
5.4.3.90	GetOutputConfig	74
5.4.3.91	GetOutputConfig	74
5.4.3.92	GetOutputConfig	75
5.4.3.93	GetOutputConfig	75
5.4.3.94	GetOutputs	75
5.4.3.95	GetPhaseAngle	75
5.4.3.96	GetPhaseMode	76
5.4.3.97	GetPosCaptureCfg	76
5.4.3.98	GetPosCaptureStat	76
5.4.3.99	GetPositionActual	77
5.4.3.100	GetPositionCommand	78
5.4.3.101	GetPositionError	78
5.4.3.102	GetPositionErrorWindow	78
5.4.3.103	GetPositionLoad	79
5.4.3.104	GetPositionMotor	79
5.4.3.105	GetPositionWarnWindow	79
5.4.3.106	GetPosLoopConfig	79
5.4.3.107	GetProfileAcc	80
5.4.3.108	GetProfileConfig	80
5.4.3.109	GetProfileDec	80
5.4.3.110	GetProfileJerk	80
5.4.3.111	GetProfileType	81
5.4.3.112	GetProfileVel	81
5.4.3.113	GetPvtBuffFree	81
5.4.3.114	GetPvtBuffStat	81
5.4.3.115	GetPvtSegID	82
5.4.3.116	GetPvtSegPos	82
5.4.3.117	GetPwmInConfig	82
5.4.3.118	GetPwmMode	82
5.4.3.119	GetQuickStop	83

5.4.3.120 GetQuickStopDec	83
5.4.3.121 GetRefVoltage	83
5.4.3.122 GetRegenConfig	83
5.4.3.123 GetSettlingTime	84
5.4.3.124 GetSettlingWindow	84
5.4.3.125 GetSoftLimits	84
5.4.3.126 GetState	85
5.4.3.127 GetStatusWord	85
5.4.3.128 GetTargetPos	85
5.4.3.129 GetTargetVel	85
5.4.3.130 GetTorqueActual	86
5.4.3.131 GetTorqueDemand	86
5.4.3.132 GetTorqueRated	86
5.4.3.133 GetTorqueSlope	86
5.4.3.134 GetTorqueTarget	87
5.4.3.135 GetTraceChannel	87
5.4.3.136 GetTraceData	87
5.4.3.137 GetTraceMaxChannel	88
5.4.3.138 GetTracePeriod	88
5.4.3.139 GetTraceRefPeriod	88
5.4.3.140 GetTraceStatus	89
5.4.3.141 GetTraceTrigger	90
5.4.3.142 GetTrackingWindows	90
5.4.3.143 GetTrajectoryAcc	90
5.4.3.144 GetTrajectoryVel	91
5.4.3.145 GetUstepConfig	91
5.4.3.146 GetVelLoopConfig	91
5.4.3.147 GetVelocityActual	92
5.4.3.148 GetVelocityCommand	93
5.4.3.149 GetVelocityLimited	93
5.4.3.150 GetVelocityLoad	93
5.4.3.151 GetVelocityProgrammed	94
5.4.3.152 GetVelocityWarnTime	94
5.4.3.153 GetVelocityWarnWindow	94
5.4.3.154 GetVloopCommandFilter	94
5.4.3.155 GetVloopOutputFilter	95
5.4.3.156 GetVloopOutputFilter2	95

5.4.3.157 GetVloopOutputFilter3	95
5.4.3.158 GoHome	95
5.4.3.159 GoHome	96
5.4.3.160 HaltMove	96
5.4.3.161 HandleStateChange	96
5.4.3.162 Init	96
5.4.3.163 Init	97
5.4.3.164 InitSubAxis	97
5.4.3.165 IsHardwareEnabled	97
5.4.3.166 IsReferenced	98
5.4.3.167 IsSoftwareEnabled	98
5.4.3.168 JrkLoad2User	98
5.4.3.169 JrkUser2Load	98
5.4.3.170 LoadFromFile	99
5.4.3.171 MoveAbs	99
5.4.3.172 MoveRel	99
5.4.3.173 PosLoad2User	100
5.4.3.174 PosMtr2User	100
5.4.3.175 PosUser2Load	100
5.4.3.176 PosUser2Mtr	101
5.4.3.177 PvtBufferFlush	101
5.4.3.178 PvtBufferPop	101
5.4.3.179 PvtClearErrors	101
5.4.3.180 PvtStatusUpdate	102
5.4.3.181 PvtWriteBuff	102
5.4.3.182 PvtWriteBuff	102
5.4.3.183 QuickStop	102
5.4.3.184 ReInit	103
5.4.3.185 Reset	103
5.4.3.186 SaveAmpConfig	103
5.4.3.187 SaveAmpConfig	103
5.4.3.188 SendTrajectory	104
5.4.3.189 SetAlgoPhaseInit	105
5.4.3.190 SetAmpConfig	105
5.4.3.191 SetAmpMode	105
5.4.3.192 SetAmpName	106
5.4.3.193 SetAnalogCommandFilter	106

5.4.3.194 SetAnalogRefConfig	106
5.4.3.195 SetCammingConfig	106
5.4.3.196 SetCanNetworkConfig	107
5.4.3.197 SetControlWord	107
5.4.3.198 SetCountsPerUnit	107
5.4.3.199 SetCountsPerUnit	108
5.4.3.200 SetCrntLoopConfig	108
5.4.3.201 SetCurrentProgrammed	109
5.4.3.202 SetDAConverterConfig	109
5.4.3.203 SetFaultMask	109
5.4.3.204 SetFuncGenConfig	109
5.4.3.205 SetGainScheduling	110
5.4.3.206 SetHaltMode	111
5.4.3.207 SetHomeAccel	111
5.4.3.208 SetHomeConfig	111
5.4.3.209 SetHomeCurrent	112
5.4.3.210 SetHomeDelay	112
5.4.3.211 SetHomeMethod	112
5.4.3.212 SetHomeOffset	112
5.4.3.213 SetHomeVelFast	113
5.4.3.214 SetHomeVelSlow	113
5.4.3.215 SetIloopCommandFilter	113
5.4.3.216 SetIloopCommandFilter2	114
5.4.3.217 SetInputConfig	115
5.4.3.218 SetInputDebounce	115
5.4.3.219 SetInputShapingFilter	115
5.4.3.220 SetIoConfig	116
5.4.3.221 SetIOOptions	116
5.4.3.222 SetIoPullup	116
5.4.3.223 SetIoPullup32	117
5.4.3.224 SetMicrostepRate	117
5.4.3.225 SetMtrInfo	117
5.4.3.226 SetNetworkOptions	117
5.4.3.227 SetOutputConfig	118
5.4.3.228 SetOutputs	118
5.4.3.229 SetPhaseMode	119
5.4.3.230 SetPosCaptureCfg	119

5.4.3.231	SetPositionActual	119
5.4.3.232	SetPositionErrorWindow	120
5.4.3.233	SetPositionLoad	120
5.4.3.234	SetPositionMotor	120
5.4.3.235	SetPositionWarnWindow	121
5.4.3.236	SetPosLoopConfig	121
5.4.3.237	SetProfileAcc	121
5.4.3.238	SetProfileConfig	121
5.4.3.239	SetProfileDec	122
5.4.3.240	SetProfileJerk	122
5.4.3.241	SetProfileType	122
5.4.3.242	SetProfileVel	123
5.4.3.243	SetPvtInitialPos	123
5.4.3.244	SetPwmInConfig	123
5.4.3.245	SetPwmMode	124
5.4.3.246	SetQuickStop	124
5.4.3.247	SetQuickStopDec	124
5.4.3.248	SetRegenConfig	124
5.4.3.249	SetSettlingTime	125
5.4.3.250	SetSettlingWindow	125
5.4.3.251	SetSoftLimits	125
5.4.3.252	SetTargetPos	126
5.4.3.253	SetTargetVel	126
5.4.3.254	SetTorqueRated	126
5.4.3.255	SetTorqueSlope	127
5.4.3.256	SetTorqueTarget	127
5.4.3.257	SetTraceChannel	127
5.4.3.258	SetTracePeriod	128
5.4.3.259	SetTraceTrigger	128
5.4.3.260	SetTrackingWindows	128
5.4.3.261	SetupMove	129
5.4.3.262	SetupMove	129
5.4.3.263	SetupMove	129
5.4.3.264	SetUstepConfig	129
5.4.3.265	SetVelLoopConfig	130
5.4.3.266	SetVelocityProgrammed	130
5.4.3.267	SetVelocityWarnTime	130

5.4.3.268	SetVelocityWarnWindow	131
5.4.3.269	SetVloopCommandFilter	131
5.4.3.270	SetVloopOutputFilter	131
5.4.3.271	SetVloopOutputFilter2	131
5.4.3.272	SetVloopOutputFilter3	132
5.4.3.273	StartMove	133
5.4.3.274	StartPVT	133
5.4.3.275	TraceStart	133
5.4.3.276	TraceStop	133
5.4.3.277	UpdateEvents	134
5.4.3.278	Upld16	135
5.4.3.279	Upld16	135
5.4.3.280	Upld32	135
5.4.3.281	Upld32	136
5.4.3.282	Upld8	136
5.4.3.283	Upld8	136
5.4.3.284	UpldString	137
5.4.3.285	Upload	137
5.4.3.286	VelLoad2User	137
5.4.3.287	VelMtr2User	138
5.4.3.288	VelUser2Load	138
5.4.3.289	VelUser2Mtr	138
5.4.3.290	WaitEvent	139
5.4.3.291	WaitEvent	139
5.4.3.292	WaitHomeDone	139
5.4.3.293	WaitInputEvent	140
5.4.3.294	WaitInputHigh	140
5.4.3.295	WaitInputLow	140
5.4.3.296	WaitMoveDone	141
5.5	AmpConfig Struct Reference	141
5.5.1	Detailed Description	144
5.5.2	Member Data Documentation	144
5.5.2.1	capCtrl	144
5.5.2.2	CME_Config	145
5.5.2.3	encoderOutCfg	145
5.5.2.4	limitBitMask	145
5.5.2.5	options	145

5.5.2.6	phaseMode	145
5.5.2.7	progCrnt	145
5.5.2.8	progVel	145
5.5.2.9	pwmMode	145
5.5.2.10	stepRate	145
5.6	AmpError Class Reference	146
5.6.1	Detailed Description	149
5.6.2	Member Function Documentation	149
5.6.2.1	DecodeStatus	149
5.7	AmpFault Class Reference	150
5.7.1	Detailed Description	152
5.7.2	Member Function Documentation	152
5.7.2.1	DecodeFault	152
5.8	AmpFileError Class Reference	153
5.8.1	Detailed Description	154
5.9	AmpInfo Struct Reference	154
5.9.1	Detailed Description	156
5.10	AmploCfg Struct Reference	156
5.10.1	Detailed Description	157
5.10.2	Constructor & Destructor Documentation	157
5.10.2.1	AmploCfg	157
5.10.3	Member Data Documentation	157
5.10.3.1	inCfg	157
5.10.3.2	inPullUpCfg	157
5.10.3.3	inPullUpCfg32	157
5.10.3.4	inputCt	157
5.10.3.5	outMask	157
5.10.3.6	outMask1	157
5.10.3.7	outputCt	158
5.11	AmpSettings Class Reference	158
5.11.1	Detailed Description	159
5.11.2	Constructor & Destructor Documentation	159
5.11.2.1	AmpSettings	159
5.11.3	Member Data Documentation	159
5.11.3.1	enableOnInit	159
5.11.3.2	guardTime	159
5.11.3.3	heartbeatPeriod	160

5.11.3.4	heartbeatTimeout	160
5.11.3.5	initialMode	160
5.11.3.6	lifeFactor	160
5.11.3.7	maxPvtSendCt	160
5.11.3.8	resetOnInit	161
5.11.3.9	synchID	161
5.11.3.10	synchPeriod	161
5.11.3.11	synchProducer	161
5.11.3.12	synchUseFirstAmp	161
5.11.3.13	timeStampID	161
5.12	AnalogRefConfig Struct Reference	162
5.12.1	Detailed Description	162
5.12.2	Member Data Documentation	162
5.12.2.1	calibration	162
5.12.2.2	deadband	162
5.12.2.3	scale	163
5.13	APRD Struct Reference	163
5.13.1	Detailed Description	164
5.14	APWR Struct Reference	164
5.14.1	Detailed Description	165
5.15	ARMW Struct Reference	165
5.15.1	Detailed Description	165
5.16	Array< C > Class Template Reference	166
5.16.1	Detailed Description	166
5.16.2	Constructor & Destructor Documentation	167
5.16.2.1	Array	167
5.16.3	Member Function Documentation	167
5.16.3.1	add	167
5.16.3.2	length	167
5.16.3.3	operator[]	167
5.16.3.4	rem	167
5.17	BRD Struct Reference	168
5.17.1	Detailed Description	168
5.18	BWR Struct Reference	169
5.18.1	Detailed Description	169
5.19	CammingConfig Struct Reference	170
5.19.1	Detailed Description	170

5.19.2	Constructor & Destructor Documentation	170
5.19.2.1	CammingConfig	170
5.19.3	Member Data Documentation	170
5.19.3.1	cammingMasterVel	170
5.20	CanError Class Reference	171
5.20.1	Detailed Description	172
5.21	CanFrame Struct Reference	172
5.21.1	Detailed Description	173
5.21.2	Member Data Documentation	173
5.21.2.1	data	173
5.21.2.2	id	173
5.21.2.3	length	173
5.22	CanInterface Class Reference	174
5.22.1	Detailed Description	175
5.22.2	Constructor & Destructor Documentation	175
5.22.2.1	CanInterface	175
5.22.3	Member Function Documentation	176
5.22.3.1	ChkID	176
5.22.3.2	Close	176
5.22.3.3	Open	176
5.22.3.4	Recv	176
5.22.3.5	RecvFrame	177
5.22.3.6	SetBaud	177
5.22.3.7	SetName	177
5.22.3.8	SupportsTimestamps	178
5.22.3.9	Xmit	178
5.22.3.10	XmitFrame	178
5.22.4	Member Data Documentation	178
5.22.4.1	portName	178
5.23	CanNetworkConfig Struct Reference	179
5.23.1	Detailed Description	180
5.23.2	Member Function Documentation	180
5.23.2.1	FromAmpFormat	180
5.23.2.2	ToAmpFormat	180
5.23.3	Member Data Documentation	180
5.23.3.1	heartbeat	181
5.23.3.2	nodeGuard	181

5.23.3.3	nodeGuardLife	181
5.23.3.4	numInPins	181
5.23.3.5	offset	181
5.23.3.6	pinMapping	181
5.23.3.7	useSwitch	181
5.24	CanOpen Class Reference	181
5.24.1	Detailed Description	184
5.24.2	Constructor & Destructor Documentation	184
5.24.2.1	CanOpen	184
5.24.2.2	~CanOpen	184
5.24.3	Member Function Documentation	184
5.24.3.1	AttachNode	184
5.24.3.2	BootModeNode	184
5.24.3.3	Close	185
5.24.3.4	DetachNode	185
5.24.3.5	DisableReceiver	185
5.24.3.6	EnableReceiver	185
5.24.3.7	GetErrorFrameCounter	186
5.24.3.8	GetNetworkType	186
5.24.3.9	GetSynchProducer	186
5.24.3.10	Open	186
5.24.3.11	Open	187
5.24.3.12	PreOpNode	187
5.24.3.13	ResetComm	187
5.24.3.14	ResetNode	187
5.24.3.15	SetNodeGuard	188
5.24.3.16	SetSynchProducer	188
5.24.3.17	StartNode	188
5.24.3.18	StopNode	188
5.24.3.19	Xmit	189
5.24.3.20	XmitPDO	189
5.24.3.21	XmitSDO	189
5.25	CanOpenError Class Reference	190
5.25.1	Detailed Description	192
5.25.2	Member Data Documentation	192
5.25.2.1	IllegalFieldCt	192
5.25.2.2	Initialized	192

5.25.2.3	MonitorRunning	192
5.25.2.4	NotInitialized	192
5.25.2.5	SDO_BadMuxRcvd	193
5.26	CanOpenNodeInfo Struct Reference	193
5.26.1	Detailed Description	194
5.26.2	Member Data Documentation	194
5.26.2.1	guardTimeout	194
5.26.2.2	guardToggle	194
5.26.2.3	guardType	194
5.27	CanOpenSettings Class Reference	195
5.27.1	Detailed Description	195
5.27.2	Constructor & Destructor Documentation	195
5.27.2.1	CanOpenSettings	195
5.27.3	Member Data Documentation	195
5.27.3.1	readThreadPriority	195
5.27.3.2	syncID	196
5.27.3.3	timeID	196
5.27.3.4	useAsTimingReference	196
5.28	CopleyCAN Class Reference	196
5.28.1	Detailed Description	198
5.28.2	Member Function Documentation	198
5.28.2.1	Close	198
5.28.2.2	Open	198
5.28.2.3	RecvFrame	198
5.28.2.4	SetBaud	199
5.28.2.5	SupportsTimestamps	199
5.28.2.6	XmitFrame	199
5.28.3	Member Data Documentation	199
5.28.3.1	local	199
5.29	CopleyIO Class Reference	200
5.29.1	Detailed Description	202
5.29.2	Constructor & Destructor Documentation	202
5.29.2.1	CopleyIO	202
5.29.2.2	CopleyIO	202
5.29.3	Member Function Documentation	203
5.29.3.1	GetIOAnlg	203
5.29.3.2	GetIOCfg	203

5.29.3.3	GetIODigi	203
5.29.3.4	GetIOInfo	203
5.29.3.5	GetOPWM	204
5.29.3.6	Init	204
5.29.3.7	Init	204
5.29.3.8	LoadFromFile	205
5.29.3.9	SaveIOConfig	205
5.29.3.10	SaveIOConfig	205
5.29.3.11	SerialCmd	205
5.29.3.12	SetIOAnlg	206
5.29.3.13	SetIOConfig	206
5.29.3.14	SetIODigi	206
5.29.3.15	SetIOInfo	207
5.29.3.16	SetOPWM	208
5.30	CopleyIOAnlg Struct Reference	208
5.30.1	Detailed Description	209
5.31	CopleyIOCfg Struct Reference	209
5.31.1	Detailed Description	210
5.32	CopleyIODigi Struct Reference	210
5.32.1	Detailed Description	211
5.33	CopleyIOInfo Struct Reference	211
5.33.1	Detailed Description	212
5.34	CopleyOPWM Struct Reference	212
5.34.1	Detailed Description	212
5.35	CopleyMotionLibrary Class Reference	213
5.35.1	Detailed Description	213
5.35.2	Constructor & Destructor Documentation	214
5.35.2.1	~CopleyMotionLibrary	214
5.35.3	Member Function Documentation	214
5.35.3.1	Debug	214
5.35.3.2	Error	214
5.35.3.3	FlushLog	214
5.35.3.4	GetDebugLevel	214
5.35.3.5	GetFlushLog	214
5.35.3.6	GetLogFile	215
5.35.3.7	GetMaxLogSize	215
5.35.3.8	GetVersionString	215

5.35.3.9	LogCAN	215
5.35.3.10	SetDebugLevel	215
5.35.3.11	SetFlushLog	216
5.35.3.12	SetLogFile	216
5.35.3.13	SetMaxLogSize	216
5.35.3.14	Warn	216
5.36	CopleyNode Class Reference	217
5.36.1	Detailed Description	218
5.36.2	Member Function Documentation	218
5.36.2.1	FirmwareUpdate	218
5.36.2.2	SerialCmd	219
5.37	CopleyNodeError Class Reference	219
5.37.1	Detailed Description	221
5.38	CrntLoopConfig Struct Reference	221
5.38.1	Detailed Description	222
5.38.2	Constructor & Destructor Documentation	222
5.38.2.1	CrntLoopConfig	222
5.38.3	Member Data Documentation	222
5.38.3.1	contLim	222
5.38.3.2	peakTime	222
5.38.3.3	slope	222
5.38.3.4	stepHoldCurrent	223
5.38.3.5	stepRun2HoldTime	223
5.38.3.6	stepVolControlDelayTime	223
5.39	DAConfig Struct Reference	223
5.39.1	Detailed Description	223
5.39.2	Member Data Documentation	223
5.39.2.1	daConverterConfig	223
5.40	IOModule::DigInPDO Class Reference	224
5.40.1	Detailed Description	225
5.40.2	Member Function Documentation	225
5.40.2.1	GetBitVal	226
5.40.2.2	GetInVal	227
5.40.2.3	Init	227
5.40.2.4	Received	227
5.41	IOModule::DigOutPDO Class Reference	228
5.41.1	Detailed Description	229

5.41.2	Member Function Documentation	229
5.41.2.1	Init	230
5.41.2.2	Transmit	231
5.41.2.3	Update	231
5.41.2.4	UpdateBit	231
5.42	EcatDgram Class Reference	232
5.42.1	Detailed Description	233
5.42.2	Constructor & Destructor Documentation	233
5.42.2.1	EcatDgram	233
5.42.2.2	EcatDgram	233
5.42.3	Member Function Documentation	233
5.42.3.1	checkNdx	233
5.42.3.2	getDgramLen	234
5.42.3.3	getNdx	234
5.42.3.4	getNext	234
5.42.3.5	Init	234
5.42.3.6	Init	234
5.42.3.7	Load	235
5.42.3.8	setData	235
5.42.3.9	setData	235
5.42.3.10	setNdx	235
5.42.3.11	setNext	235
5.43	EcatFrame Class Reference	236
5.43.1	Detailed Description	236
5.44	Error Class Reference	237
5.44.1	Detailed Description	239
5.44.2	Constructor & Destructor Documentation	240
5.44.2.1	Error	240
5.44.3	Member Function Documentation	240
5.44.3.1	GetID	240
5.44.3.2	Lookup	240
5.44.3.3	toString	241
5.45	EtherCAT Class Reference	241
5.45.1	Detailed Description	243
5.45.2	Member Function Documentation	243
5.45.2.1	AddToFrame	243
5.45.2.2	FoE_DnldData	243

5.45.2.3	FoE_DnldStart	244
5.45.2.4	FoE_LastErrInfo	244
5.45.2.5	FoE_UpldData	244
5.45.2.6	FoE_UpldStart	245
5.45.2.7	GetIdFromEEPROM	245
5.45.2.8	GetNetworkType	245
5.45.2.9	GetNodeAddress	246
5.45.2.10	getNodeCount	246
5.45.2.11	InitDistClk	246
5.45.2.12	MailboxTransfer	246
5.45.2.13	maxSdoFromNode	247
5.45.2.14	maxSdoToNode	248
5.45.2.15	SetNodeGuard	248
5.45.2.16	SetSync0Period	248
5.45.2.17	WaitCycleUpdate	249
5.46	EtherCatError Class Reference	249
5.46.1	Detailed Description	251
5.47	EtherCatHardware Class Reference	252
5.47.1	Detailed Description	252
5.48	EtherCatSettings Class Reference	253
5.48.1	Detailed Description	253
5.48.2	Constructor & Destructor Documentation	253
5.48.2.1	EtherCatSettings	253
5.48.3	Member Data Documentation	253
5.48.3.1	cyclePeriod	253
5.48.3.2	cycleThreadPriority	253
5.48.3.3	readThreadPriority	254
5.49	Event Class Reference	254
5.49.1	Detailed Description	255
5.49.2	Constructor & Destructor Documentation	255
5.49.2.1	Event	255
5.49.2.2	~Event	255
5.49.2.3	Event	255
5.49.3	Member Function Documentation	256
5.49.3.1	delChain	256
5.49.3.2	getMask	256
5.49.3.3	getValue	256

5.49.3.4	isTrue	256
5.49.3.5	operator=	256
5.49.3.6	setChain	257
5.49.3.7	setValue	257
5.49.3.8	Wait	257
5.50	EventAll Class Reference	258
5.50.1	Detailed Description	259
5.50.2	Constructor & Destructor Documentation	259
5.50.2.1	EventAll	259
5.50.2.2	EventAll	259
5.50.3	Member Function Documentation	259
5.50.3.1	isTrue	259
5.51	EventAny Class Reference	260
5.51.1	Detailed Description	260
5.51.2	Constructor & Destructor Documentation	261
5.51.2.1	EventAny	261
5.51.2.2	EventAny	261
5.51.3	Member Function Documentation	261
5.51.3.1	isTrue	261
5.52	EventAnyClear Class Reference	261
5.52.1	Detailed Description	262
5.52.2	Constructor & Destructor Documentation	263
5.52.2.1	EventAnyClear	263
5.52.2.2	EventAnyClear	264
5.52.3	Member Function Documentation	264
5.52.3.1	isTrue	264
5.53	EventError Class Reference	264
5.53.1	Detailed Description	265
5.54	EventMap Class Reference	265
5.54.1	Detailed Description	266
5.54.2	Constructor & Destructor Documentation	266
5.54.2.1	~EventMap	266
5.54.3	Member Function Documentation	266
5.54.3.1	Add	266
5.54.3.2	changeBits	267
5.54.3.3	clrBits	267
5.54.3.4	getMask	267

5.54.3.5	Remove	267
5.54.3.6	setBits	267
5.54.3.7	setMask	268
5.55	EventNone Class Reference	269
5.55.1	Detailed Description	270
5.55.2	Constructor & Destructor Documentation	270
5.55.2.1	EventNone	270
5.55.2.2	EventNone	270
5.55.3	Member Function Documentation	270
5.55.3.1	isTrue	270
5.56	Filter Class Reference	271
5.56.1	Detailed Description	271
5.56.2	Constructor & Destructor Documentation	271
5.56.2.1	Filter	271
5.56.3	Member Function Documentation	271
5.56.3.1	LoadFromCCX	271
5.57	Firmware Class Reference	272
5.57.1	Detailed Description	272
5.57.2	Member Function Documentation	272
5.57.2.1	getAmpType	272
5.57.2.2	getData	272
5.57.2.3	getFileVersion	273
5.57.2.4	getLength	273
5.57.2.5	getStart	273
5.57.2.6	progress	273
5.58	FirmwareError Class Reference	273
5.58.1	Detailed Description	275
5.59	FPRD Struct Reference	275
5.59.1	Detailed Description	276
5.60	FPWR Struct Reference	276
5.60.1	Detailed Description	277
5.61	FuncGenConfig Struct Reference	277
5.61.1	Detailed Description	278
5.61.2	Member Data Documentation	278
5.61.2.1	amp	278
5.62	GainScheduling Struct Reference	278
5.62.1	Detailed Description	278

5.62.2	Constructor & Destructor Documentation	278
5.62.2.1	GainScheduling	278
5.63	HomeConfig Struct Reference	279
5.63.1	Detailed Description	279
5.63.2	Constructor & Destructor Documentation	279
5.63.2.1	HomeConfig	279
5.63.3	Member Data Documentation	279
5.63.3.1	accel	279
5.63.3.2	current	280
5.63.3.3	delay	280
5.63.3.4	extended	280
5.63.3.5	offset	280
5.63.3.6	velFast	280
5.63.3.7	velSlow	280
5.64	InputShaper Class Reference	280
5.64.1	Detailed Description	281
5.64.2	Constructor & Destructor Documentation	281
5.64.2.1	InputShaper	281
5.64.3	Member Function Documentation	281
5.64.3.1	LoadFromCCX	281
5.65	IOError Class Reference	281
5.65.1	Detailed Description	283
5.66	IOFileError Class Reference	283
5.66.1	Detailed Description	284
5.67	IOModule Class Reference	284
5.67.1	Detailed Description	294
5.67.2	Constructor & Destructor Documentation	294
5.67.2.1	IOModule	294
5.67.2.2	IOModule	294
5.67.2.3	IOModule	294
5.67.3	Member Function Documentation	295
5.67.3.1	Ain16GetCt	295
5.67.3.2	Ain16GetLowerLimit	295
5.67.3.3	Ain16GetNegativeDelta	295
5.67.3.4	Ain16GetPositiveDelta	295
5.67.3.5	Ain16GetUnsignedDelta	296
5.67.3.6	Ain16GetUpperLimit	296

5.67.3.7	Ain16Read	296
5.67.3.8	Ain16SetLowerLimit	297
5.67.3.9	Ain16SetNegativeDelta	297
5.67.3.10	Ain16SetPositiveDelta	297
5.67.3.11	Ain16SetUnsignedDelta	297
5.67.3.12	Ain16SetUpperLimit	298
5.67.3.13	Ain32GetCt	298
5.67.3.14	Ain32GetLowerLimit	298
5.67.3.15	Ain32GetNegativeDelta	299
5.67.3.16	Ain32GetOffset	300
5.67.3.17	Ain32GetPositiveDelta	300
5.67.3.18	Ain32GetScaling	300
5.67.3.19	Ain32GetUnsignedDelta	300
5.67.3.20	Ain32GetUpperLimit	301
5.67.3.21	Ain32Read	301
5.67.3.22	Ain32SetLowerLimit	301
5.67.3.23	Ain32SetNegativeDelta	302
5.67.3.24	Ain32SetOffset	303
5.67.3.25	Ain32SetPositiveDelta	303
5.67.3.26	Ain32SetScaling	303
5.67.3.27	Ain32SetUnsignedDelta	303
5.67.3.28	Ain32SetUpperLimit	304
5.67.3.29	Ain8GetCt	304
5.67.3.30	Ain8Read	304
5.67.3.31	AinFltGetCt	304
5.67.3.32	AinFltGetLowerLimit	305
5.67.3.33	AinFltGetNegativeDelta	305
5.67.3.34	AinFltGetOffset	305
5.67.3.35	AinFltGetPositiveDelta	306
5.67.3.36	AinFltGetScaling	307
5.67.3.37	AinFltGetUnsignedDelta	307
5.67.3.38	AinFltGetUpperLimit	307
5.67.3.39	AinFltRead	307
5.67.3.40	AinFltSetLowerLimit	308
5.67.3.41	AinFltSetNegativeDelta	308
5.67.3.42	AinFltSetOffset	308
5.67.3.43	AinFltSetPositiveDelta	309

5.67.3.44 AinFltSetScaling	310
5.67.3.45 AinFltSetUnsignedDelta	310
5.67.3.46 AinFltSetUpperLimit	310
5.67.3.47 AinGetIntEna	311
5.67.3.48 AinGetIntSource	312
5.67.3.49 AinGetTrigType	312
5.67.3.50 AinSetIntEna	312
5.67.3.51 AinSetTrigType	313
5.67.3.52 Aout16GetCt	314
5.67.3.53 Aout16GetErrValue	314
5.67.3.54 Aout16SetErrValue	314
5.67.3.55 Aout16Write	315
5.67.3.56 Aout32GetCt	316
5.67.3.57 Aout32GetErrValue	316
5.67.3.58 Aout32GetOffset	316
5.67.3.59 Aout32GetScaling	316
5.67.3.60 Aout32SetErrValue	317
5.67.3.61 Aout32SetOffset	317
5.67.3.62 Aout32SetScaling	317
5.67.3.63 Aout32Write	317
5.67.3.64 Aout8GetCt	318
5.67.3.65 Aout8Write	318
5.67.3.66 AoutFltGetCt	318
5.67.3.67 AoutFltGetErrValue	318
5.67.3.68 AoutFltGetOffset	319
5.67.3.69 AoutFltGetScaling	319
5.67.3.70 AoutFltSetErrValue	319
5.67.3.71 AoutFltSetOffset	319
5.67.3.72 AoutFltSetScaling	320
5.67.3.73 AoutFltWrite	320
5.67.3.74 AoutGetErrMode	320
5.67.3.75 AoutSetErrMode	321
5.67.3.76 BitCount	321
5.67.3.77 BitDnld	321
5.67.3.78 BitUpld	321
5.67.3.79 Din16GetCt	322
5.67.3.80 Din16GetFilt	322

5.67.3.81 Din16GetMaskAny	322
5.67.3.82 Din16GetMaskHigh2Low	323
5.67.3.83 Din16GetMaskLow2High	323
5.67.3.84 Din16GetPol	323
5.67.3.85 Din16Read	323
5.67.3.86 Din16SetFilt	324
5.67.3.87 Din16SetMaskAny	324
5.67.3.88 Din16SetMaskHigh2Low	324
5.67.3.89 Din16SetMaskLow2High	325
5.67.3.90 Din16SetPol	325
5.67.3.91 Din32GetCt	325
5.67.3.92 Din32GetFilt	325
5.67.3.93 Din32GetMaskAny	326
5.67.3.94 Din32GetMaskHigh2Low	326
5.67.3.95 Din32GetMaskLow2High	326
5.67.3.96 Din32GetPol	327
5.67.3.97 Din32Read	327
5.67.3.98 Din32SetFilt	327
5.67.3.99 Din32SetMaskAny	328
5.67.3.100Din32SetMaskHigh2Low	329
5.67.3.101Din32SetMaskLow2High	329
5.67.3.102Din32SetPol	329
5.67.3.103Din8GetCt	330
5.67.3.104Din8GetFilt	331
5.67.3.105Din8GetMaskAny	331
5.67.3.106Din8GetMaskHigh2Low	331
5.67.3.107Din8GetMaskLow2High	332
5.67.3.108Din8GetPol	332
5.67.3.109Din8Read	332
5.67.3.110Din8SetFilt	332
5.67.3.111Din8SetMaskAny	333
5.67.3.112Din8SetMaskHigh2Low	333
5.67.3.113Din8SetMaskLow2High	333
5.67.3.114Din8SetPol	334
5.67.3.115DinGetCt	334
5.67.3.116DinGetFilt	334
5.67.3.117DinGetIntEna	334

5.67.3.118DinGetMaskAny	335
5.67.3.119DinGetMaskHigh2Low	335
5.67.3.120DinGetMaskLow2High	335
5.67.3.121DinGetPol	336
5.67.3.122DinRead	337
5.67.3.123DinSetFilt	337
5.67.3.124DinSetIntEna	337
5.67.3.125DinSetMaskAny	338
5.67.3.126DinSetMaskHigh2Low	338
5.67.3.127DinSetMaskLow2High	338
5.67.3.128DinSetPol	338
5.67.3.129Dout16GetCt	339
5.67.3.130Dout16GetErrMode	339
5.67.3.131Dout16GetErrValue	339
5.67.3.132Dout16GetFilt	340
5.67.3.133Dout16GetPol	340
5.67.3.134Dout16Read	340
5.67.3.135Dout16SetErrMode	340
5.67.3.136Dout16SetErrValue	341
5.67.3.137Dout16SetFilt	341
5.67.3.138Dout16SetPol	341
5.67.3.139Dout16Write	342
5.67.3.140Dout32GetCt	342
5.67.3.141Dout32GetErrMode	342
5.67.3.142Dout32GetErrValue	342
5.67.3.143Dout32GetFilt	343
5.67.3.144Dout32GetPol	343
5.67.3.145Dout32Read	343
5.67.3.146Dout32SetErrMode	344
5.67.3.147Dout32SetErrValue	344
5.67.3.148Dout32SetFilt	344
5.67.3.149Dout32SetPol	344
5.67.3.150Dout32Write	345
5.67.3.151Dout8GetCt	345
5.67.3.152Dout8GetErrMode	345
5.67.3.153Dout8GetErrValue	346
5.67.3.154Dout8GetFilt	346

5.67.3.155Dout8GetPol	346
5.67.3.156Dout8Read	347
5.67.3.157Dout8SetErrMode	348
5.67.3.158Dout8SetErrValue	348
5.67.3.159Dout8SetFilt	348
5.67.3.160Dout8SetPol	349
5.67.3.161Dout8Write	349
5.67.3.162DoutGetCt	349
5.67.3.163DoutGetErrMode	350
5.67.3.164DoutGetErrValue	350
5.67.3.165DoutGetFilt	350
5.67.3.166DoutGetPol	350
5.67.3.167DoutSetErrMode	351
5.67.3.168DoutSetErrValue	351
5.67.3.169DoutSetFilt	351
5.67.3.170DoutSetPol	352
5.67.3.171DoutWrite	352
5.67.3.172Init	352
5.67.3.173Init	353
5.67.3.174PostIOEvent	353
5.67.3.175WaitIOEvent	353
5.67.3.176WaitIOEvent	354
5.68 IModuleSettings Struct Reference	354
5.68.1 Detailed Description	355
5.68.2 Member Data Documentation	355
5.68.2.1 guardTime	355
5.68.2.2 heartbeatPeriod	355
5.68.2.3 heartbeatTimeout	355
5.68.2.4 lifeFactor	356
5.68.2.5 useStandardAinPDO	356
5.68.2.6 useStandardAoutPDO	356
5.68.2.7 useStandardDinPDO	356
5.68.2.8 useStandardDoutPDO	356
5.69 IxxatCAN Class Reference	356
5.69.1 Detailed Description	358
5.69.2 Constructor & Destructor Documentation	358
5.69.2.1 IxxatCAN	358

5.69.2.2	IxxatCAN	358
5.69.2.3	~IxxatCAN	359
5.69.3	Member Function Documentation	359
5.69.3.1	Close	359
5.69.3.2	ConvertError	359
5.69.3.3	Open	359
5.69.3.4	RecvFrame	360
5.69.3.5	rxInt	361
5.69.3.6	SetBaud	361
5.69.3.7	XmitFrame	361
5.69.4	Member Data Documentation	362
5.69.4.1	channel	362
5.70	IxxatCANV3 Class Reference	362
5.70.1	Detailed Description	364
5.70.2	Member Function Documentation	364
5.70.2.1	Close	364
5.70.2.2	ConvertError	364
5.70.2.3	Open	364
5.70.2.4	RecvFrame	364
5.70.2.5	SetBaud	365
5.70.2.6	XmitFrame	365
5.70.3	Member Data Documentation	365
5.70.3.1	channel	365
5.71	KvaserCAN Class Reference	366
5.71.1	Detailed Description	367
5.71.2	Constructor & Destructor Documentation	367
5.71.2.1	KvaserCAN	367
5.71.2.2	KvaserCAN	368
5.71.2.3	~KvaserCAN	368
5.71.3	Member Function Documentation	368
5.71.3.1	Close	368
5.71.3.2	ConvertError	368
5.71.3.3	Open	368
5.71.3.4	RecvFrame	369
5.71.3.5	SetBaud	370
5.71.3.6	XmitFrame	370
5.72	Linkage Class Reference	370

5.72.1	Detailed Description	373
5.72.2	Constructor & Destructor Documentation	373
5.72.2.1	Linkage	373
5.72.3	Member Function Documentation	373
5.72.3.1	ClearLatchedError	373
5.72.3.2	Configure	373
5.72.3.3	ConvertAmpToAxis	374
5.72.3.4	ConvertAmpToAxisPos	374
5.72.3.5	ConvertAxisToAmp	374
5.72.3.6	ConvertAxisToAmpPos	374
5.72.3.7	GetAmp	376
5.72.3.8	GetAmpCount	376
5.72.3.9	GetAmpRef	376
5.72.3.10	GetAxesCount	376
5.72.3.11	GetLatchedError	377
5.72.3.12	GetMoveLimits	377
5.72.3.13	GetPositionCommand	377
5.72.3.14	HaltMove	378
5.72.3.15	Init	378
5.72.3.16	Init	378
5.72.3.17	MoveTo	379
5.72.3.18	MoveTo	379
5.72.3.19	operator[]	379
5.72.3.20	SendTrajectory	380
5.72.3.21	SetMoveLimits	380
5.72.3.22	StartMove	380
5.72.3.23	WaitEvent	380
5.72.3.24	WaitEvent	381
5.72.3.25	WaitMoveDone	381
5.73	LinkError Class Reference	381
5.73.1	Detailed Description	383
5.73.2	Member Data Documentation	383
5.73.2.1	NetworkMismatch	383
5.73.2.2	NotSupported	383
5.74	LinkSettings Class Reference	384
5.74.1	Detailed Description	384
5.74.2	Constructor & Destructor Documentation	384

5.74.2.1	LinkSettings	384
5.74.3	Member Data Documentation	384
5.74.3.1	haltOnPosWarn	384
5.74.3.2	haltOnVelWin	384
5.74.3.3	moveAckTimeout	385
5.75	LinkTrajectory Class Reference	385
5.75.1	Detailed Description	386
5.75.2	Member Function Documentation	387
5.75.2.1	Finish	387
5.75.2.2	GetDim	387
5.75.2.3	MaximumBufferPointsToUse	387
5.75.2.4	NextSegment	387
5.75.2.5	StartNew	388
5.75.2.6	UseVelocityInfo	388
5.76	LinkTrjScurve Class Reference	388
5.76.1	Detailed Description	390
5.76.2	Member Function Documentation	390
5.76.2.1	Calculate	390
5.76.2.2	GetDim	390
5.76.2.3	NextSegment	390
5.76.2.4	StartNew	391
5.77	LinuxEcatHardware Class Reference	391
5.77.1	Detailed Description	392
5.78	LSS Class Reference	392
5.78.1	Detailed Description	394
5.78.2	Constructor & Destructor Documentation	394
5.78.2.1	LSS	394
5.78.3	Member Function Documentation	394
5.78.3.1	FindAmplifiers	394
5.78.3.2	FindAmpSerial	395
5.78.3.3	GetAmpNodeID	395
5.78.3.4	getTimeout	395
5.78.3.5	NewFrame	396
5.78.3.6	SelectAmp	397
5.78.3.7	SetAmpNodeID	397
5.78.3.8	setTimeout	397
5.78.3.9	Xmit	397

5.79 MtrInfo Struct Reference	398
5.79.1 Detailed Description	400
5.79.2 Constructor & Destructor Documentation	400
5.79.2.1 MtrInfo	400
5.79.3 Member Data Documentation	400
5.79.3.1 gearRatio	400
5.79.3.2 hallVelShift	400
5.79.3.3 loadEncOptions	400
5.79.3.4 loadEncRes	401
5.79.3.5 loadEncType	401
5.79.3.6 mtrEncOptions	401
5.79.3.7 poles	401
5.79.3.8 resolverCycles	401
5.80 Mutex Class Reference	401
5.80.1 Detailed Description	402
5.80.2 Member Function Documentation	402
5.80.2.1 Lock	402
5.80.2.2 Unlock	402
5.81 MutexLocker Class Reference	402
5.81.1 Detailed Description	403
5.81.2 Constructor & Destructor Documentation	403
5.81.2.1 MutexLocker	403
5.82 Network Class Reference	403
5.82.1 Detailed Description	404
5.82.2 Member Function Documentation	404
5.82.2.1 GetNodeInfo	404
5.82.2.2 maxSdoFromNode	405
5.82.2.3 maxSdoToNode	405
5.82.2.4 SetNodeInfo	405
5.83 NetworkError Class Reference	406
5.83.1 Detailed Description	407
5.84 NetworkNodeInfo Class Reference	407
5.84.1 Detailed Description	407
5.85 NetworkOptions Struct Reference	407
5.85.1 Detailed Description	408
5.85.2 Constructor & Destructor Documentation	408
5.85.2.1 NetworkOptions	408

5.86 Node Class Reference	408
5.86.1 Detailed Description	411
5.86.2 Constructor & Destructor Documentation	411
5.86.2.1 Node	411
5.86.2.2 Node	411
5.86.3 Member Function Documentation	412
5.86.3.1 ClearErrorHistory	412
5.86.3.2 GetDeviceType	412
5.86.3.3 GetErrorHistory	412
5.86.3.4 GetErrorRegister	412
5.86.3.5 GetIdentity	413
5.86.3.6 GetMfgDeviceName	413
5.86.3.7 GetMfgHardwareVer	413
5.86.3.8 GetMfgSoftwareVer	413
5.86.3.9 GetMfgStatus	414
5.86.3.10 GetNetworkRef	414
5.86.3.11 GetNetworkType	414
5.86.3.12 GetNodeID	414
5.86.3.13 GetState	415
5.86.3.14 GetSynchId	415
5.86.3.15 GetSynchPeriod	415
5.86.3.16 HandleEmergency	415
5.86.3.17 HandleStateChange	415
5.86.3.18 Init	416
5.86.3.19 maxSdoFromNode	416
5.86.3.20 maxSdoToNode	416
5.86.3.21 PdoDisable	416
5.86.3.22 PdoEnable	417
5.86.3.23 PdoSet	417
5.86.3.24 PreOpNode	417
5.86.3.25 ResetComm	417
5.86.3.26 ResetNode	418
5.86.3.27 RpdoDisable	418
5.86.3.28 SetSynchId	418
5.86.3.29 SetSynchPeriod	418
5.86.3.30 StartHeartbeat	418
5.86.3.31 StartNode	419

5.86.3.32 StartNodeGuard	419
5.86.3.33 StopGuarding	419
5.86.3.34 StopNode	419
5.86.3.35 SynchStart	420
5.86.3.36 SynchStop	420
5.86.3.37 TpdoDisable	420
5.86.3.38 UnInit	420
5.86.4 Member Data Documentation	420
5.86.4.1 sdo	420
5.87 NodeError Class Reference	421
5.87.1 Detailed Description	422
5.88 NodeIdentity Struct Reference	422
5.88.1 Detailed Description	422
5.89 Path Class Reference	423
5.89.1 Detailed Description	424
5.89.2 Constructor & Destructor Documentation	424
5.89.2.1 Path	424
5.89.3 Member Function Documentation	425
5.89.3.1 AddArc	425
5.89.3.2 AddArc	425
5.89.3.3 AddLine	425
5.89.3.4 AddLine	426
5.89.3.5 GetDim	426
5.89.3.6 NextSegment	426
5.89.3.7 Pause	426
5.89.3.8 PlayPath	427
5.89.3.9 Reset	427
5.89.3.10 SetAcc	427
5.89.3.11 SetDec	428
5.89.3.12 SetJrk	428
5.89.3.13 SetStartPos	428
5.89.3.14 SetVel	428
5.89.3.15 StartNew	429
5.90 PathError Class Reference	429
5.90.1 Detailed Description	431
5.91 PcapEcatHardware Class Reference	431
5.91.1 Detailed Description	432

5.91.2	Constructor & Destructor Documentation	432
5.91.2.1	PcapEcatHardware	432
5.91.3	Member Function Documentation	433
5.91.3.1	GetAdapterDesc	433
5.91.3.2	GetAdapterName	433
5.92	PDO Class Reference	433
5.92.1	Detailed Description	436
5.92.2	Member Function Documentation	436
5.92.2.1	AddVar	436
5.92.2.2	ClearMap	436
5.92.2.3	GetID	436
5.92.2.4	GetMapCodes	436
5.92.2.5	GetRtrOk	437
5.92.2.6	GetType	437
5.92.2.7	SetID	437
5.92.2.8	SetType	437
5.92.3	Member Data Documentation	437
5.92.3.1	map	437
5.93	PDO_Error Class Reference	438
5.93.1	Detailed Description	439
5.93.2	Member Data Documentation	439
5.93.2.1	BitOverflow	439
5.94	Pmap Class Reference	439
5.94.1	Detailed Description	440
5.94.2	Constructor & Destructor Documentation	440
5.94.2.1	Pmap	440
5.94.3	Member Function Documentation	440
5.94.3.1	Get	440
5.94.3.2	GetBits	441
5.94.3.3	GetIndex	441
5.94.3.4	GetSub	441
5.94.3.5	Init	441
5.94.3.6	Set	441
5.95	Pmap16 Class Reference	442
5.95.1	Detailed Description	443
5.95.2	Constructor & Destructor Documentation	443
5.95.2.1	Pmap16	443

5.95.3	Member Function Documentation	443
5.95.3.1	Get	443
5.95.3.2	Init	443
5.95.3.3	Read	444
5.95.3.4	Set	444
5.95.3.5	Write	444
5.96	Pmap24 Class Reference	444
5.96.1	Detailed Description	446
5.96.2	Constructor & Destructor Documentation	446
5.96.2.1	Pmap24	446
5.96.3	Member Function Documentation	446
5.96.3.1	Get	446
5.96.3.2	Init	446
5.96.3.3	Read	446
5.96.3.4	Set	447
5.96.3.5	Write	447
5.97	Pmap32 Class Reference	447
5.97.1	Detailed Description	448
5.97.2	Constructor & Destructor Documentation	448
5.97.2.1	Pmap32	448
5.97.3	Member Function Documentation	449
5.97.3.1	Get	449
5.97.3.2	Init	449
5.97.3.3	Read	449
5.97.3.4	Set	449
5.97.3.5	Write	450
5.98	Pmap8 Class Reference	451
5.98.1	Detailed Description	452
5.98.2	Constructor & Destructor Documentation	452
5.98.2.1	Pmap8	452
5.98.3	Member Function Documentation	452
5.98.3.1	Get	452
5.98.3.2	Init	452
5.98.3.3	Read	453
5.98.3.4	Set	453
5.98.3.5	Write	453
5.99	PmapRaw Class Reference	453

5.99.1 Detailed Description	454
5.99.2 Constructor & Destructor Documentation	455
5.99.2.1 PmapRaw	455
5.99.3 Member Function Documentation	455
5.99.3.1 Get	455
5.99.3.2 Set	455
5.100Point< N > Class Template Reference	455
5.100.1 Detailed Description	456
5.100.2 Member Function Documentation	457
5.100.2.1 getDim	457
5.100.2.2 getMax	457
5.100.2.3 setDim	457
5.101PointN Class Reference	457
5.101.1 Detailed Description	458
5.101.2 Member Function Documentation	458
5.101.2.1 getDim	458
5.101.2.2 getMax	459
5.101.2.3 setDim	459
5.102PosLoopConfig Struct Reference	459
5.102.1 Detailed Description	460
5.102.2 Constructor & Destructor Documentation	460
5.102.2.1 PosLoopConfig	460
5.102.3 Member Data Documentation	460
5.102.3.1 scale	460
5.103ProfileConfig Struct Reference	460
5.103.1 Detailed Description	461
5.103.2 Member Data Documentation	461
5.103.2.1 abort	461
5.103.2.2 pos	461
5.104ProfileConfigScurve Struct Reference	461
5.104.1 Detailed Description	462
5.104.2 Member Data Documentation	462
5.104.2.1 acc	462
5.104.2.2 jrk	462
5.104.2.3 pos	462
5.104.2.4 vel	462
5.105ProfileConfigTrap Struct Reference	462

5.105.1 Detailed Description	463
5.105.2 Member Data Documentation	463
5.105.2.1 acc	463
5.105.2.2 dec	463
5.105.2.3 pos	463
5.105.2.4 vel	463
5.106 ProfileConfigVel Struct Reference	464
5.106.1 Detailed Description	464
5.106.2 Member Data Documentation	464
5.106.2.1 acc	464
5.106.2.2 dec	464
5.106.2.3 dir	464
5.106.2.4 vel	465
5.107 PvtSegCache Class Reference	465
5.107.1 Detailed Description	465
5.107.2 Member Function Documentation	465
5.107.2.1 AddSegment	465
5.107.2.2 GetPosition	466
5.107.2.3 GetSegment	466
5.108 PwmInConfig Struct Reference	466
5.108.1 Detailed Description	467
5.108.2 Member Data Documentation	467
5.108.2.1 cfg	467
5.108.2.2 freq	467
5.108.2.3 scale	467
5.108.2.4 uvCfg	467
5.109 Receiver Class Reference	468
5.109.1 Detailed Description	468
5.109.2 Constructor & Destructor Documentation	469
5.109.2.1 ~Receiver	469
5.109.3 Member Function Documentation	469
5.109.3.1 NewFrame	469
5.110 RefObj Class Reference	469
5.110.1 Detailed Description	471
5.110.2 Constructor & Destructor Documentation	471
5.110.2.1 RefObj	471
5.110.2.2 ~RefObj	472

5.110.3 Member Function Documentation	472
5.110.3.1 GrabRef	472
5.110.3.2 KillRef	472
5.110.3.3 LockRef	472
5.110.3.4 LogRefs	472
5.110.3.5 ReleaseRef	473
5.110.3.6 setAutoDelete	474
5.110.3.7 SetRefName	474
5.111 RefObjLocker< RefClass > Class Template Reference	474
5.111.1 Detailed Description	474
5.111.2 Constructor & Destructor Documentation	475
5.111.2.1 RefObjLocker	475
5.111.3 Member Function Documentation	475
5.111.3.1 operator*	475
5.111.3.2 operator->	475
5.112 RegenConfig Struct Reference	475
5.112.1 Detailed Description	476
5.112.2 Constructor & Destructor Documentation	476
5.112.2.1 RegenConfig	476
5.112.3 Member Data Documentation	476
5.112.3.1 contPower	476
5.112.3.2 model	476
5.112.3.3 peakPower	476
5.112.3.4 peakTime	477
5.112.3.5 vOff	477
5.112.3.6 vOn	477
5.113 RPDO Class Reference	477
5.113.1 Detailed Description	478
5.113.2 Constructor & Destructor Documentation	478
5.113.2.1 RPDO	479
5.113.3 Member Function Documentation	480
5.113.3.1 Init	480
5.113.3.2 LoadData	480
5.114 RPDO_LinkCtrl Class Reference	480
5.114.1 Detailed Description	482
5.114.2 Member Function Documentation	482
5.114.2.1 Init	482

5.114.2.2 Transmit	482
5.115ScurveError Class Reference	482
5.115.1 Detailed Description	484
5.116SDO Class Reference	484
5.116.1 Detailed Description	485
5.116.2 Constructor & Destructor Documentation	485
5.116.2.1 SDO	485
5.116.3 Member Function Documentation	486
5.116.3.1 BlockDnld	486
5.116.3.2 BlockUpd	486
5.116.3.3 DisableBlkDnld	486
5.116.3.4 DisableBlkUpd	486
5.116.3.5 Dnld16	487
5.116.3.6 Dnld16	488
5.116.3.7 Dnld32	488
5.116.3.8 Dnld32	488
5.116.3.9 Dnld8	489
5.116.3.10Dnld8	490
5.116.3.11DnldFlt	490
5.116.3.12DnldString	490
5.116.3.13Download	491
5.116.3.14Download	491
5.116.3.15EnableBlkDnld	491
5.116.3.16EnableBlkUpd	491
5.116.3.17GetMaxRetry	492
5.116.3.18GetTimeout	492
5.116.3.19init	492
5.116.3.20SetTimeout	492
5.116.3.21Upd16	492
5.116.3.22Upd16	493
5.116.3.23Upd32	493
5.116.3.24Upd32	493
5.116.3.25Upd8	493
5.116.3.26Upd8	494
5.116.3.27UpdFlt	494
5.116.3.28UpdString	494
5.116.3.29Upload	495

5.116.3.30 Upload	495
5.117 SDO_Error Class Reference	496
5.117.1 Detailed Description	498
5.118 Semaphore Class Reference	498
5.118.1 Detailed Description	499
5.118.2 Constructor & Destructor Documentation	499
5.118.2.1 Semaphore	499
5.118.2.2 ~Semaphore	499
5.118.3 Member Function Documentation	499
5.118.3.1 Get	499
5.118.3.2 Put	499
5.119 ServoLoopConfig Struct Reference	500
5.119.1 Detailed Description	500
5.119.2 Member Data Documentation	500
5.119.2.1 servoLoopConfig	500
5.120 SoftPosLimit Struct Reference	500
5.120.1 Detailed Description	501
5.120.2 Member Data Documentation	501
5.120.2.1 accel	501
5.120.2.2 macroEncoderCapture	501
5.120.2.3 motorPosWrap	501
5.120.2.4 neg	501
5.120.2.5 pos	502
5.121 Thread Class Reference	502
5.121.1 Detailed Description	503
5.121.2 Constructor & Destructor Documentation	503
5.121.2.1 Thread	503
5.121.3 Member Function Documentation	503
5.121.3.1 getTimeMS	503
5.121.3.2 run	503
5.121.3.3 setPriority	503
5.121.3.4 sleep	504
5.121.3.5 start	504
5.121.3.6 stop	504
5.122 ThreadError Class Reference	505
5.122.1 Detailed Description	506
5.123 TPDO Class Reference	506

5.123.1 Detailed Description	508
5.123.2 Member Function Documentation	508
5.123.2.1 ProcessData	508
5.123.2.2 Received	508
5.123.2.3 SetRtrOk	508
5.124 TrackingWindows Struct Reference	508
5.124.1 Detailed Description	509
5.124.2 Constructor & Destructor Documentation	509
5.124.2.1 TrackingWindows	509
5.124.3 Member Data Documentation	509
5.124.3.1 settlingTime	509
5.124.3.2 settlingWin	509
5.124.3.3 trackErr	509
5.124.3.4 trackWarn	510
5.125 Trajectory Class Reference	510
5.125.1 Detailed Description	511
5.125.2 Member Function Documentation	511
5.125.2.1 Finish	511
5.125.2.2 MaximumBufferPointsToUse	511
5.125.2.3 NextSegment	512
5.125.2.4 StartNew	512
5.125.2.5 UseVelocityInfo	512
5.126 TrjError Class Reference	513
5.126.1 Detailed Description	514
5.126.2 Member Data Documentation	514
5.126.2.1 NoneAvailable	514
5.127 TrjScurve Class Reference	514
5.127.1 Detailed Description	515
5.127.2 Constructor & Destructor Documentation	516
5.127.2.1 TrjScurve	516
5.127.3 Member Function Documentation	516
5.127.3.1 Calculate	516
5.127.3.2 Calculate	516
5.127.3.3 GetStartPos	517
5.127.3.4 SetStartPos	517
5.127.3.5 StartNew	517
5.128 UstepConfig Struct Reference	518

5.128.1 Detailed Description	518
5.128.2 Constructor & Destructor Documentation	518
5.128.2.1 UstepConfig	518
5.128.3 Member Data Documentation	518
5.128.3.1 maxVelAdj	518
5.128.3.2 ustepConfigAndStatus	518
5.128.3.3 ustepPGainOutLoop	519
5.129VelLoopConfig Struct Reference	519
5.129.1 Detailed Description	520
5.129.2 Constructor & Destructor Documentation	520
5.129.2.1 VelLoopConfig	520
5.129.3 Member Data Documentation	520
5.129.3.1 estopDec	520
5.129.3.2 maxAcc	520
5.129.3.3 maxDec	520
5.129.3.4 maxVel	520
5.129.3.5 shift	521
5.129.3.6 velCmdff	521
5.130WinUdpEcatHardware Class Reference	521
5.130.1 Detailed Description	522
5.130.2 Constructor & Destructor Documentation	522
5.130.2.1 WinUdpEcatHardware	522
6 File Documentation	525
6.1 Amp.cpp File Reference	525
6.1.1 Detailed Description	525
6.2 AmpFile.cpp File Reference	525
6.2.1 Detailed Description	526
6.3 AmpFW.cpp File Reference	526
6.3.1 Detailed Description	526
6.4 AmpParam.cpp File Reference	527
6.4.1 Detailed Description	527
6.5 AmpPDO.cpp File Reference	527
6.5.1 Detailed Description	527
6.6 AmpPVT.cpp File Reference	528
6.6.1 Detailed Description	528
6.7 AmpStruct.cpp File Reference	528

6.7.1	Detailed Description	528
6.8	AmpUnits.cpp File Reference	529
6.8.1	Detailed Description	529
6.9	AmpVersion.cpp File Reference	529
6.9.1	Detailed Description	529
6.10	Can.cpp File Reference	530
6.10.1	Detailed Description	530
6.11	can_copley.h File Reference	530
6.11.1	Detailed Description	532
6.12	can_ixxat.h File Reference	532
6.12.1	Detailed Description	533
6.13	can_ixxat_v3.h File Reference	533
6.13.1	Detailed Description	534
6.14	can_kvaser.h File Reference	534
6.14.1	Detailed Description	535
6.15	CanOpen.cpp File Reference	536
6.15.1	Detailed Description	536
6.16	CML.cpp File Reference	536
6.16.1	Detailed Description	537
6.17	CML.h File Reference	537
6.17.1	Detailed Description	538
6.17.2	Enumeration Type Documentation	538
6.17.2.1	CML_LOG_LEVEL	538
6.18	CML_Amp.h File Reference	538
6.18.1	Detailed Description	539
6.19	CML_AmpDef.h File Reference	540
6.19.1	Enumeration Type Documentation	548
6.19.1.1	AMP_EVENT	548
6.19.1.2	AMP_FAULT	549
6.19.1.3	AMP_FEATURE	550
6.19.1.4	AMP_MODE	551
6.19.1.5	AMP_PHASE_MODE	553
6.19.1.6	AMP_PWM_MODE	553
6.19.1.7	AMP_TRACE_STATUS	554
6.19.1.8	AMP_TRACE_TRIGGER	554
6.19.1.9	AMP_TRACE_VAR	554
6.19.1.10	COPLEY_HOME_METHOD	556

6.19.1.11	EVENT_STATUS	558
6.19.1.12	HALT_MODE	559
6.19.1.13	INPUT_PIN_CONFIG	559
6.19.1.14	OUTPUT_PIN_CONFIG	560
6.19.1.15	POS_CAPTURE_CFG	561
6.19.1.16	POS_CAPTURE_STAT	562
6.19.1.17	PROFILE_TYPE	562
6.19.1.18	QUICK_STOP_MODE	563
6.20	CML_AmpStruct.h File Reference	563
6.20.1	Detailed Description	566
6.20.2	Enumeration Type Documentation	566
6.20.2.1	CAN_BIT_RATE	566
6.21	CML_Array.h File Reference	566
6.21.1	Detailed Description	567
6.22	CML_Can.h File Reference	567
6.22.1	Detailed Description	569
6.22.2	Enumeration Type Documentation	569
6.22.2.1	CAN_FRAME_TYPE	569
6.23	CML_CanOpen.h File Reference	569
6.23.1	Detailed Description	571
6.24	CML_Copley.h File Reference	571
6.24.1	Detailed Description	572
6.25	CML_CopleyIO.h File Reference	572
6.25.1	Detailed Description	575
6.25.2	Enumeration Type Documentation	575
6.25.2.1	CIO_OBJID	575
6.26	CML_Error.h File Reference	576
6.26.1	Detailed Description	577
6.27	CML_EtherCAT.h File Reference	577
6.27.1	Detailed Description	579
6.28	CML_EventMap.h File Reference	579
6.28.1	Detailed Description	581
6.29	CML_File.h File Reference	581
6.29.1	Detailed Description	582
6.30	CML_Filter.h File Reference	582
6.30.1	Detailed Description	583
6.31	CML_Firmware.h File Reference	583

6.31.1 Detailed Description	584
6.32 CML_Geometry.h File Reference	585
6.32.1 Detailed Description	585
6.33 CML_InputShaper.h File Reference	586
6.33.1 Detailed Description	587
6.34 CML_IO.h File Reference	587
6.34.1 Detailed Description	590
6.34.2 Enumeration Type Documentation	590
6.34.2.1 IO_AIN_TRIG_TYPE	590
6.34.2.2 IO_OBJID	590
6.34.2.3 IOMODULE_EVENTS	592
6.35 CML_Linkage.h File Reference	593
6.35.1 Detailed Description	594
6.35.2 Enumeration Type Documentation	594
6.35.2.1 LINK_EVENT	594
6.36 CML_Network.h File Reference	595
6.36.1 Detailed Description	597
6.36.2 Enumeration Type Documentation	597
6.36.2.1 GuardProtocol	597
6.36.2.2 NetworkType	598
6.36.2.3 NodeState	598
6.37 CML_Node.h File Reference	598
6.37.1 Detailed Description	599
6.38 CML_PDO.h File Reference	599
6.38.1 Detailed Description	601
6.39 CML_Reference.h File Reference	601
6.39.1 Detailed Description	603
6.40 CML_SDO.h File Reference	603
6.40.1 Detailed Description	605
6.40.2 Macro Definition Documentation	605
6.40.2.1 SDO_BLK_DNLD_THRESHOLD	605
6.40.2.2 SDO_BLK_UPLD_THRESHOLD	605
6.41 CML_Settings.h File Reference	605
6.41.1 Detailed Description	607
6.41.2 Macro Definition Documentation	607
6.41.2.1 CML_ALLOW_FLOATING_POINT	607
6.41.2.2 CML_DEBUG_ASSERT	607

6.41.2.3	CML_ENABLE_IOMODULE_PDOS	607
6.41.2.4	CML_ENABLE_USER_UNITS	607
6.41.2.5	CML_ERROR_HASH_SIZE	608
6.41.2.6	CML_ERROR_MESSAGES	608
6.41.2.7	CML_FILE_ACCESS_OK	608
6.41.2.8	CML_HASH_SIZE	608
6.41.2.9	CML_LINKAGE_TRJ_BUFFER_SIZE	608
6.41.2.10	CML_MAX_AMPS_PER_LINK	608
6.41.2.11	CML_MAX_ECAT_FRAMES	608
6.41.2.12	CML_NAMESPACE	609
6.41.2.13	CML_NAMESPACE_START	609
6.42	CML_Threads.h File Reference	609
6.42.1	Detailed Description	611
6.43	CML_Trajectory.h File Reference	611
6.44	CML_TrjScurve.h File Reference	612
6.44.1	Detailed Description	613
6.45	CML_Utills.h File Reference	613
6.45.1	Detailed Description	614
6.45.2	Macro Definition Documentation	615
6.45.2.1	ByteCast	615
6.45.3	Typedef Documentation	615
6.45.3.1	int16	615
6.45.3.2	int32	615
6.45.3.3	int64	615
6.45.3.4	uint16	615
6.45.3.5	uint32	615
6.45.3.6	uunit	615
6.46	CopleyIO.cpp File Reference	616
6.46.1	Detailed Description	616
6.47	CopleyNode.cpp File Reference	616
6.47.1	Detailed Description	617
6.48	ecatdc.cpp File Reference	617
6.48.1	Detailed Description	617
6.49	Error.cpp File Reference	617
6.49.1	Detailed Description	618
6.50	EtherCAT.cpp File Reference	618
6.50.1	Detailed Description	618

6.50.2 Macro Definition Documentation	618
6.50.2.1 SM_RXMBX	618
6.51 EventMap.cpp File Reference	618
6.51.1 Detailed Description	619
6.52 File.cpp File Reference	619
6.52.1 Detailed Description	619
6.53 Filter.cpp File Reference	619
6.53.1 Detailed Description	620
6.54 Firmware.cpp File Reference	621
6.55 Geometry.cpp File Reference	622
6.56 InputShaper.cpp File Reference	622
6.56.1 Detailed Description	622
6.57 IOmodule.cpp File Reference	622
6.57.1 Detailed Description	623
6.58 Linkage.cpp File Reference	623
6.58.1 Detailed Description	623
6.59 Network.cpp File Reference	624
6.59.1 Detailed Description	624
6.60 Node.cpp File Reference	624
6.60.1 Detailed Description	625
6.61 PDO.cpp File Reference	625
6.61.1 Detailed Description	625
6.62 Reference.cpp File Reference	625
6.62.1 Detailed Description	626
6.63 SDO.cpp File Reference	626
6.63.1 Detailed Description	626
6.64 Threads.cpp File Reference	626
6.64.1 Detailed Description	627
Index	628

Chapter 1

Copley Motion Library

1.1 Introduction

The Copley Motion Library is a collection of C++ objects which are intended to simplify the development of CANopen and EtherCAT based products. These libraries allow low level access to the CANopen and EtherCAT networks while also providing high level methods for easy development of network based motion control applications.

1.1.1 Supported platforms

The Copley Motion Library is designed to be highly platform independent. The only requirements of a platform are:

- C++ must be supported. The Copley Motion Library makes heavy use of the object oriented features of the C++ language. Porting it to standard C would require significant effort.
- Multi-tasking. The library uses multiple threads of execution. For this reason, some type of multi-tasking operating system is required. A real time operating system is desirable, but not necessary.
- Network hardware. Some sort of CAN hardware must be available for CANopen support. An Ethernet port must be available for EtherCAT support.

The majority of the library code should be easily portable across platforms, even to those systems that do not have a very complete C++ implementation. In particular, the standard C and C++ libraries have been avoided to the extent possible.

1.1.2 Multi-tasking support

The C++ language does not define any standard method for multi-tasking, so a generic multi-tasking layer has been defined for use by this library. Three classes have been defined in the header file [CML_Threads.h](#) which define the multi-tasking interface. These classes are;

- [Thread](#): An independent thread of execution.
- [Mutex](#): A mechanism used to provide mutually exclusive access to a variable or system resource.
- [Semaphore](#): A mechanism used to control access to a resource pool. This object allows threads to pend on it with timeouts.

When porting the library to a new environment, these three objects will need to be implemented for that environment. The libraries currently support multi-tasking under posix compatible operating systems (most Unix varieties including Linux), and MS Windows.

1.1.3 CAN hardware support

The Copley Motion Libraries have been designed to use a generic interface to the low level CAN network hardware. This makes porting the libraries to new CAN hardware very straight forward. All CAN hardware access is routed through the [CanInterface](#) object defined in the header file [CML_Can.h](#). This object defines generic methods to open, close, read from, and write to the CAN network. Adding support for new CAN interface hardware is as simple as implementing a new [CanInterface](#) object derived from this class.

1.1.4 EtherCAT hardware support

When communicating over an EtherCAT network, CML uses the standard operating system API calls to access the Ethernet hardware. No special device drivers other than those normally used to access the Ethernet hardware are required.

Note that EtherCAT requires a dedicated Ethernet port. It is generally not possible to share a single Ethernet port for both a EtherCAT and general Ethernet communications at the same time.

1.2 CANopen basics

CAN (Control Area Network) is a serial network originally developed for use in the automotive industry. The physical layer of CAN consists of a two wire differentially driven bus, typically terminated with 120 Ohm resistors on each end. The maximum bit rate supported by CAN is 1,000,000 bits/second for up to 25 meters. Lower bit rates may be used for longer network lengths.

Communication over the CAN bus takes the form of network packets. Each packet consists of an identifier, some control bits, and zero to eight bytes of data. Each packet is sent with CRC information which allows the CAN controllers on the network to identify and re-send incorrectly formatted packets.

The identifier sent with each CAN packet identifies the type of packet being sent, as well as the priority of the packet. If two or more devices on the network attempt to transmit packets at the same time, the one sending the higher priority packet will succeed. The device sending the lower priority packet will detect the network collision and automatically back off the network and re-try the transmission later. The fact that the higher priority packet is transmitted when a network collision occurs allows very high network bandwidth utilization. Other network technologies (such as Ethernet) would require both transmitting devices to abort their transmissions if a network collision was detected.

CANopen is a high level protocol used to communicate over a CAN network. It allows blocks of data larger than the eight byte CAN limit to be transmitted as a single entity. Additionally, CANopen defines a standard framework for device operation which simplifies communication between dissimilar devices.

In most cases a CANopen network consists of one master device, and multiple slave devices (also called network nodes). Each of the nodes on the network has a 7-bit node ID number associated with it in the range 1 to 127 (the node ID 0 is reserved, and should not be used). The Copley Motion Libraries are designed to run on the CANopen network master.

1.2.1 CANopen Object Dictionary

One of the central concepts defined by the CANopen protocol is the notion of an object dictionary. This is essentially a collection of parameters on each device which define its configuration and status. Most communication over the CA-

Nopen network consists of uploading data to, and downloading data from the object dictionaries of the various devices.

Each entry in the object dictionary is accessed using a 16-bit index value. Most entries in a device's object dictionary are simple atomic types (16-bit integers, 32-bit integers, strings, etc), however entries may be defined as complex types (records or arrays). In this case, the individual elements in the record or array are accessed using an additional 8-bit sub-index. It is not possible for these objects to be of complex types, so nesting of structures is not allowed.

1.2.2 SDO

The majority of traffic over the CANopen network consists of the network master reading and writing to the object dictionaries of the slave devices (nodes) on the network. The primary mechanism through which this is accomplished is the Service Data Object (SDO).

Each node on the CANopen network is required to implement at least one SDO. The SDO is essentially a channel that can be opened between a network master and a slave for the purpose of reading from and writing to the slave's object dictionary.

SDO transfers are always initiated by the master, and always confirmed by the slave. The synchronous nature of the SDO makes error detection very straight forward. However, since every transfer using an SDO takes at least two CAN messages (one from the master to the slave, one from the slave to the master) they can be somewhat slow for the transfer of real time information.

For example, for the network master to update an object which holds an eight byte long value, six CAN messages will be required:

- 1.The master sends a message to the slave indicating it's intentions to update the object. In this message it sends the object's index and sub-index values. It also passes the size (in bytes) of the data that will be transferred.
- 2.The slave responds to the master indicating that it is ready to receive the data.
- 3.The master sends the first 7 bytes of data. SDO transfers use one byte of the CAN message data for header information, so the largest amount of data that can be passed in any single message is 7 bytes.
- 4.The slave responds indicating that it received the data and is ready for more.
- 5.The master sends the remaining byte of data.
- 6.The slave responds indicating success.

1.2.3 PDO

A second method of accessing the data in the node's object dictionaries is defined by CANopen. This method is called the Process Data Object (PDO) and is primarily used to transfer frequently changing real-time data.

Unlike an SDO, a PDO can be initiated by either the network master, or the slave device. In fact, unlike SDO transfers, PDO transfers do not really follow a master - slave model. Any device on the network can initiate a PDO transfer, and a PDO message can be received and processed by multiple devices on the network.

Every PDO message consists of exactly one CAN message. Unlike SDO transfers, there is no confirmation with PDO transfers. This has the benefit of making much better use of the CAN network bandwidth, but since there is no response to a PDO, some other mechanism must be found to determine if the message was received successfully.

For example, updating the value of an 8-byte long variable in a device's object dictionary using a PDO can be accomplished in one CAN message, unlike the 6 messages that it required using SDO transfers.

- 1.The master sends a CAN message containing the 8-bytes of data. No additional header information is passed in the message, and no response is sent.

Of course, since all 8 bytes of the CAN message data were used to hold the object's value, there is no place to transmit the index / sub-index of the object being updated. This information must be implied based on the CAN message ID associated with the PDO. To create this association, a PDO must be mapped to one or more objects in a device's object dictionary before it can be used. This is accomplished by using SDO transfers, and effectively tells the device which object(s) a particular PDO transfer will access.

The result is that sending a PDO like in the above example requires a bit of setup using SDO transfers. It's therefore not useful to use a PDO transfer to update an object's value just once, since this could be more efficiently done using a single SDO transfer. However, if a particular object needs to be updated repeatedly, then the overhead of mapping a PDO to it makes more sense.

Aside from efficiency issues, PDO transfers have some other useful features. SDO transfers are inherently one master to one slave. PDO transfers can be used to broadcast a message to multiple other devices on the network. This is useful for synchronizing the start of a multi-axis move, for example.

Additionally, a slave device can be configured to transmit the value of one (or more) of the objects in its object dictionary either at a set frequency, or when some internal event occurs. This would also be accomplished using PDO transfers.

1.2.4 Network management

Most communication over the CANopen network consists of reading and writing values to a device's object dictionary using either SDO or PDO transfers. There are however several other message types which are required by the CANopen protocol.

Network management messages are used to control the state of the devices on the CANopen network. Every CANopen device implements a simple state machine which is controlled through the use of these messages. The following states are defined:

- Pre-operational: Every node enters this state after power-up or reset. In this state, the device is not functional, but will communicate over the CANopen network. PDO transfers are not allowed in pre-operational state, but SDO transfers may be used.
- Operational: This is the normal operating state for all devices. SDO and PDO transfers are both allowed.
- Stopped: No communication is allowed in this state except for network management messages. Neither SDO nor PDO transfers may be used.

One use of network management messages is to control these state changes on the network devices. The following network management messages are sent by the network manager to control these state changes. Each of these messages can be either sent to a single node (by node ID), or broadcast to all the nodes on the network.

- Reset. This message causes the receiving node(s) to perform a soft reset and come up in pre-operation state.
- Reset communications. Causes the receiving node(s) to reset their CANopen network to its power-on state, and enter pre-operational state. This is not a full device reset, just a reset of the CANopen interface.
- Pre-operational. This message causes the receiving node(s) to enter pre-operational state. No reset is performed.
- Start. Causes the node(s) to enter operational state.
- Stop. Causes the node(s) to enter stopped state.

In addition to controlling the device's state machines, network management messages can be used to monitor the operation of the nodes on the CANopen network. There are two protocols to perform this task; heartbeat and node guarding.

The heartbeat protocol is very simple, the network master configures the node to transmit a heartbeat message at some interval. The heartbeat message is then sent by the node at the specified frequency. The only information passed in the

heartbeat message is the current state of the node (i.e. pre-operational, operational or stopped). The network manager can monitor these messages, and if anything happens to the node (or the network connection to the node) it can detect this by the lack of heartbeat messages.

Node guarding is similar. The network manager configures the node to expect node guarding messages at some interval. The network manager then sends a message to the configured node at that frequency, and the node responds with a node guarding message. This allows both the network manager and slave device to identify a network failure if the guarding messages stop.

1.2.5 SYNC messages

Another type of message defined by the CANopen protocol is the SYNC message. This is a message that one device is configured to transmit at some interval, and that all other devices on the network receive. It can be used for device synchronization, and PDO transfers can be configured to be sent in response to the SYNC event.

Every CANopen network should have one (and only one) device which is configured to produce SYNC messages (the SYNC producer). Other devices on the network which receive the SYNC messages are SYNC consumers.

Copley Controls amplifiers are able to be configured as both SYNC producers and SYNC consumers. The default configuration for every amplifier after reset is as a SYNC consumer. The Copley Motion Library [Amp](#) class constructor will configure one of the amplifiers as a SYNC producer by default.

1.2.6 Emergency messages

Emergency messages are sent by CANopen devices when some error condition is detected. They contain information about the type of error condition as well as manufacturer specific information not defined by the CANopen spec.

1.3 EtherCAT basics

The EtherCAT network is a high performance field bus based on the Ethernet physical layer. There are several different high level protocols that can be implemented on top of EtherCAT, but the most common protocol, and the one supported by CML, is the CANopen over EtherCAT (CoE) protocol. When using this protocol, the EtherCAT network acts very much like a high speed CANopen network supporting an object dictionary, SDO and PDO access just like in CANopen.

One significant difference between the EtherCAT network and CANopen network is that in the CANopen network the nodes are able to transmit their status updates any time they like. In the EtherCAT network the network master needs to poll the status of the nodes.

1.4 Architectural overview

The Copley Motion Libraries are made up of a large number of classes, but several are of primary importance and will be used for every program. This section gives a brief overview of the most important of these classes. Detailed documentation of each of the provided classes is provided later in the manual.

1.4.1 CanInterface

This class has already been mentioned above. It is one of the few classes that is highly platform dependent. The [CanInterface](#) class is used to abstract the CAN network interface hardware available on the system.

Typically, one of the first objects created in a program using the Copley Motion Libraries is a [CanInterface](#) object. This will in turn be passed to the [CanOpen](#) object.

1.4.2 EtherCatHardware

This class is the generic representation of the Ethernet hardware interface used by the operating system. Like the [CanInterface](#) object, the exact details of this class's implementation will be different depending on the operating system being used.

1.4.3 Network class

The [Network](#) class represents an EtherCAT or CANopen network.

1.4.4 CanOpen class

The [CanOpen](#) class is derived from the [Network](#) class and represents the CANopen network. The Open method of this class must be called before the class can be used. This method takes a reference to a [CanInterface](#) object as it's only parameter. The [CanOpen](#) class will then attempt to open the CAN interface (by calling [CanInterface::Open](#) method), and if that is successful it will start a new thread which will be responsible for reading messages from the CAN interface.

It is possible to have more than one [CanOpen](#) object in a system. Each should be connected to a distinct CAN network, and each should therefore be passed a distinct [CanInterface](#) object.

The primary responsibility of the [CanOpen](#) object is to listen for messages on the CAN network. To perform this task, the [CanOpen](#) object creates a separate high priority thread which constantly monitors the CAN network for new messages. Every time a new message is received, the read thread searches for a [Receiver](#) object associated with the message's CAN ID. If such an object is found, it's handler method is called to process the message.

1.4.5 EtherCAT class

The [EtherCAT](#) class is derived from the [Network](#) class and represents the EtherCAT network. The Open method of this class must be called before the class can be used. This method takes a reference to a [EtherCatHardware](#) object as it's only parameter. That object will be used to perform the low level communications with the Ethernet hardware.

1.4.6 Receiver class

[Receiver](#) objects are used to listen for messages on the CAN network. Each [Receiver](#) object has a CAN message ID associated with it. When a message is received which has this ID value, the [CanOpen](#) object will search for a [Receiver](#) object with that ID. If no such [Receiver](#) is found, the message will be ignored. If a [Receiver](#) object with a matching ID is found, then the virtual [Receiver::NewFrame\(\)](#) method will be called.

1.4.7 Node class

The [Node](#) class represents a node (slave device) on the CANopen network. This class is passed a node ID value, and a reference to a [CanOpen](#) object during construction. The [CanOpen](#) object identifies which network the [Node](#) is connected to.

The [Node](#) class defines various methods to read and write standard objects from the node's object dictionary. The objects that are built into the [Node](#) class are those that are defined in the CANopen communication specification (D-S301).

The [Node](#) class also includes logic which allows it to transmit and monitor the node guarding (or heartbeat) protocols for the device on the network. If the device being monitored stops responding, or changes state, the virtual method [HandleStateChange\(\)](#) will be called. By default this does nothing, but it may be extended to perform any necessary action to handle the condition.

1.4.8 Amp class

The [Amp](#) inherits from the [Node](#) class, and is used to represent a Copley Controls amplifier on the CANopen network. This class includes numerous methods used to get and set various amplifier parameters. The [Amp](#) class also includes several high level methods used to make point to point moves, home the amplifier, and stream complex PVT style profiles down to the amplifier.

Chapter 2

Hierarchical Index

2.1 Class Hierarchy

This inheritance list is sorted roughly, but not completely, alphabetically:

AlgoPhaseInit	25
AmpConfig	141
AmplInfo	154
AmploCfg	156
AmpSettings	158
AnalogRefConfig	162
Array< C >	166
Array< PDO_Info >	166
CammingConfig	170
CanFrame	172
CanNetworkConfig	179
CanOpenSettings	195
CopleyIOAnlg	208
CopleyIOCfg	209
CopleyIODigi	210
CopleyIOInfo	211
CopleyIOPWM	212
CopleyMotionLibrary	213
CrntLoopConfig	221
DAConfig	223
EcatDgram	232
APRD	163
APWR	164
ARMW	165
BRD	168
BWR	169
FPRD	275
FPWR	276
Error	237
AmpFileError	153
CanError	171
CanOpenError	190
EtherCatError	249

EventError	264
FirmwareError	273
IOFileError	283
LinkError	381
NetworkError	406
NodeError	421
AmpError	146
AmpFault	150
CopleyNodeError	219
IOError	281
PathError	429
PDO_Error	438
ScurveError	482
SDO_Error	496
ThreadError	505
TrjError	513
EtherCatSettings	253
Event	254
EventAll	258
EventAny	260
EventAnyClear	261
EventNone	269
EventMap	265
Filter	271
Firmware	272
FuncGenConfig	277
GainScheduling	278
HomeConfig	279
InputShaper	280
IOModuleSettings	354
LinkSettings	384
MtrlInfo	398
Mutex	401
MutexLocker	402
NetworkNodeInfo	407
CanOpenNodeInfo	193
NetworkOptions	407
NodeIdentity	422
Pmap	439
Pmap16	442
Pmap24	444
Pmap32	447
Pmap8	451
PmapRaw	453
PointN	457
Point< N >	455
Point< CML_MAX_AMPS_PER_LINK >	455
Point< PATH_MAX_DIMENSIONS >	455
PosLoopConfig	459
ProfileConfig	460
ProfileConfigScurve	461
ProfileConfigTrap	462
ProfileConfigVel	464

PvtSegCache	465
PwmInConfig	466
RefObj	469
CanInterface	174
CopleyCAN	196
IxxatCAN	356
IxxatCANV3	362
KvaserCAN	366
EcatFrame	236
EtherCatHardware	252
LinuxEcatHardware	391
PcapEcatHardware	431
WinUdpEcatHardware	521
Linkage	370
LinkTrajectory	385
LinkTrjScurve	388
Path	423
Network	403
CanOpen	181
EtherCAT	241
Node	408
CopleyNode	217
Amp	29
IOModule	284
CopleyIO	200
PDO	433
RPDO	477
IOModule::AlgOutPDO	26
IOModule::DigOutPDO	228
RPDO_LinkCtrl	480
TPDO	506
IOModule::AlgInPDO	23
IOModule::DigInPDO	224
Receiver	468
LSS	392
Trajectory	510
TrjScurve	514
RefObjLocker< RefClass >	474
RegenConfig	475
SDO	484
Semaphore	498
ServoLoopConfig	500
SoftPosLimit	500
Thread	502
CanOpen	181
Linkage	370
TrackingWindows	508
UstepConfig	518
VelLoopConfig	519

Chapter 3

Class Index

3.1 Class List

Here are the classes, structs, unions and interfaces with brief descriptions:

IOModule::AlgInPDO	Transmit PDO for mapping analog inputs	23
AlgoPhaseInit	Configuration structure used to set up algorithmic phase init	25
IOModule::AlgOutPDO	Receive PDO for mapping analog outputs	26
Amp	Copley Controls amplifier object	29
AmpConfig	Amplifier configuration structure	141
AmpError	This class represents error conditions that can occur in the Copley Amplifier object	146
AmpFault	This class represents latching amplifier fault conditions	150
AmpFileError	This class represents error conditions that can occur when loading amplifier data from a data file	153
AmpInfo	Amplifier characteristics data structure	154
AmpIoCfg	Programmable I/O pin configuration	156
AmpSettings	Copley amplifier settings object	158
AnalogRefConfig	Analog input configuration	162
APRD	Read by position in network (aka Auto Increment Physical Read) The read is performed on the node who's position matches the passed address	163
APWR	Write by position in network (Auto Increment Physical Write) Like the APRD datagram, but a write version	164
ARMW	Read by position in network and write to the same address of all following nodes	165
Array< C >	This class template implements a simple dynamic array of a given type	166

BRD	Broadcast read	168
BWR	Broadcast write. This type of datagram writes data to the same location on every node in the network	169
CammingConfig	Configuration structure used to set up the camming	170
CanError	Class used to represent an error condition returned from a CAN interface function	171
CanFrame	Low level CAN data frame	172
CanInterface	Abstract class used for low level interaction with CAN hardware	174
CanNetworkConfig	CANopen Node ID and bit rate configuration	179
CanOpen	Top level interface into the CANopen network	181
CanOpenError	This class holds the error codes that describe CANopen error conditions	190
CanOpenNodeInfo	The CanOpenNodeInfo structure holds some data required by the CANopen network interface which is present in every node it manages	193
CanOpenSettings	Configuration object used to customize global settings for the CANopen network	195
CopleyCAN	This class extends the generic CanInterface class into a working interface for the Copley can device driver	196
CopleyIO	This class represents a Copley CANopen I/O module	200
CopleyIOAnlg	This structure is used to return information about the analog inputs of a Copley I/O module	208
CopleyIOCfg	IO Module configuration structure	209
CopleyIODigi	This structure is used to return information about the digital I/O of a Copley I/O module	210
CopleyIOInfo	IO Module characteristics data structure	211
CopleyIOPWM	This structure is used to return information about the PWM outputs of a Copley I/O module	212
CopleyMotionLibrary	Copley Motion Libraries utility object	213
CopleyNode	Copley CANopen Node class	217
CopleyNodeError	This class represents errors that can be returned by the CopleyNode class	219
CrntLoopConfig	This structure holds the current loop configuration parameters	221
DAConfig	Configuration structure used to hold the settings for a drive's D/A converter	223
IOModule::DigInPDO	Transmit PDO for mapping digital inputs	224
IOModule::DigOutPDO	Receive PDO for mapping digital output pins	228
EcatDgram	Generic EtherCAT datagram class	232

EcatFrame		
EtherCAT frame class	236
Error		
This class is the root class for all error codes returned by functions defined within the Motion Library		237
EtherCAT		
Top level interface into the EtherCAT network	241
EtherCatError		
This class holds the error codes that describe EtherCAT error conditions	249
EtherCatHardware		
Low level Ethernet hardware interface	252
EtherCatSettings		
Configuration object used to customize global settings for the EtherCAT network	253
Event		
Events are a generic mechanism used to wait on some condition	254
EventAll		
This is an event that matches if all of a group of bits are set in the EventMap mask	258
EventAny		
This is an event that matches if any of a group of bits are set in the EventMap mask	260
EventAnyClear		
This is an event that matches if any of a group of bits are clear in the EventMap mask	261
EventError		
This class represents error conditions related to the Event object	264
EventMap		
An event map is a mechanism that allows one or more threads to wait on some pre-defined event, or group of events	265
EventNone		
This is an event that matches if none of a group of bits are set in the EventMap mask	269
Filter		
Generic filter structure	271
Firmware		
Copley Controls amplifier firmware object	272
FirmwareError		
This class represents error conditions that can occur while accessing a Copley Controls amplifier firmware object	273
FPRD		
Read by assigned node ID (Configured Address Physical Read) The master assigns each node a unique 16-bit address at startup	275
FPWR		
Write by assigned node ID (Configured Address Physical Write)	276
FuncGenConfig		
Configuration parameters for amplifier's internal function generator	277
GainScheduling		
Configuration structure used to set up the Gain Scheduling	278
HomeConfig		
Homing parameter structure	279
InputShaper		
Generic input shaper structure	280
IOError		
I/O module errors	281
IOFileError		
This class represents error conditions that can occur when loading IO module data from a data file	283
IOModule		
Standard CANopen I/O module	284

IOModuleSettings	Standard CANopen I/O module settings	354
IxxatCAN	Ixxat specific CAN interface	356
IxxatCANV3	Ixxat specific CAN interface	362
KvaserCAN	Kvaser specific CAN interface	366
Linkage	Linkage object, used for controlling a group of coordinated amplifiers	370
LinkError	This class represents error conditions that can occur in the Linkage class	381
LinkSettings	Linkage object settings	384
LinkTrajectory	Linkage trajectory	385
LinkTrjScurve	Multi-axis s-curve profile	388
LinuxEcatHardware	This class provides an interface to the Ethernet ports on a linux system	391
LSS	CANopen Layer Setting Services object	392
MtrInfo	Motor information structure	398
Mutex	This class represents an object that can be used by multiple threads to gain safe access to a shared resource	401
MutexLocker	This is a utility class that locks a mutex in it's constructor, and unlocks it in it's destructor	402
Network	Abstract network class	403
NetworkError	This class holds the error codes that describe various Network error conditions	406
NetworkNodeInfo	Private data owned by the network object attached to every node	407
NetworkOptions	Configuration structure used to configure the amplifiers network support	407
Node	Node class	408
NodeError	This class represents node errors	421
NodeIdentity	CANopen identity object	422
Path	Multi-axis complex trajectory path	423
PathError	This class represents errors returned by the path Path object	429
PcapEcatHardware	This class provides an interface to the Ethernet ports on a Windows system using the winpcap library	431
PDO	PDO (Process Data Object) base class	433
PDO_Error	This class represents error conditions related to PDOs	438

Pmap	This class allows variables to be mapped into a PDO	439
Pmap16	This is a PDO variable mapping class that extends the virtual Pmap class to handle 16-bit integers	442
Pmap24	This is a PDO variable mapping class that extends the virtual Pmap class to handle 24-bit integers	444
Pmap32	This is a PDO variable mapping class that extends the virtual Pmap class to handle 32-bit integers	447
Pmap8	This is a PDO variable mapping class that extends the virtual Pmap class to handle 8-bit integers	451
PmapRaw	This is the most generic PDO variable mapping class	453
Point< N >	Template used for N dimensional objects	455
PointN	An N axis point	457
PosLoopConfig	This structure holds the position loop configuration parameters specific to the Copley amplifier	459
ProfileConfig	Amplifier profile parameters	460
ProfileConfigScurve	S-curve profile parameters	461
ProfileConfigTrap	Trapezoidal profile parameters	462
ProfileConfigVel	Velocity profile parameters	464
PvtSegCache	PVT trajectory segment cache object	465
PwmInConfig	PWM or Pulse/Direction input configuration	466
Receiver	CANopen receiver object	468
RefObj	This class is used to track object references in the CML library	469
RefObjLocker< RefClass >	This is a utility class that locks a reference in it's constructor, and unlocks it in it's destructor	474
RegenConfig	Configuration structure used to set up the amplifier regeneration resistor	475
RPDO	Receive PDO (received by node, transmitted by this software)	477
RPDO_LinkCtrl	Receive PDO used to update the control word of all amplifiers in the linkage	480
ScurveError	This class represents error conditions that can occur in the TrjScurve class	482
SDO	CANopen Service Data Object (SDO)	484
SDO_Error	This class represents SDO errors	496
Semaphore	Generic semaphore class	498
ServoLoopConfig	This structure holds configuration info about specific parts of the velocity and position loops	500
SoftPosLimit	Software limit switch configuration	500

Thread	Virtual class which provides multi-tasking	502
ThreadError	Errors related to the multi-threaded libraries	505
TPDO	Transmit PDO (transmitted by node, received by this software)	506
TrackingWindows	Position and velocity error windows	508
Trajectory	Trajectory information class	510
TrjError	This class represents error conditions reported by the trajectory classes	513
TrjScurve	Asymmetric S-curve profile generator	514
UstepConfig	Configuration structure used to set up the microstepper	518
VelLoopConfig	This structure holds the velocity loop configuration parameters specific to the Copley amplifier	519
WinUdpEcatHardware	This class provides an interface to the Ethernet ports on a windows system	521

Chapter 4

File Index

4.1 File List

Here is a list of all documented files with brief descriptions:

Amp.cpp	This file provides most of the implementation for the Copley Amplifier object	525
AmpFile.cpp	This file contains code used to read a CME-2 .ccx amplifier file	525
AmpFW.cpp	This file contains code used to update an amplifier's firmware over the CANopen network	526
AmpParam.cpp	This file contains the AMP object methods used to upload / download various amplifier parameters	527
AmpPDO.cpp	This file contains code that implements PDO objects used by the Copley Controls amplifier object	527
AmpPVT.cpp	This file contains the code used by the Amp object to stream PVT trajectory profiles over the CANopen network	528
AmpStruct.cpp	This file contains the AMP object methods used to upload / download structures containing groups of amplifier parameters	528
AmpUnits.cpp	This file contains the AMP object methods used to handle unit conversions	529
AmpVersion.cpp	This file contains some rules used by the Amp object to determine if certain features are supported by the amplifier based on it's model number and firmware version number	529
Can.cpp	This file handles the initialization of the static variables (error codes) used by the CanError and CanInterface classes	530
can_copley.h	CAN hardware interface for the Copley Controls CAN card	530
can_ixxat.h	CAN hardware interface for the Ixxat CAN driver	532
can_ixxat_v3.h	CAN hardware interface for the Ixxat CAN driver	533
can_kvaser.h	CAN hardware interface for the Kvaser CAN driver	534
CanOpen.cpp	This file holds code for the top level CANopen class	536

CML.cpp	
CML object definition	536
CML.h	
Top level include file for the CML libraries	537
CML_Amp.h	
This file defines the Copley Amplifier object	538
CML_AmpDef.h	540
CML_AmpStruct.h	
This file contains a number of structures used to pass configuration parameters to an Amp object	563
CML_Array.h	
This file implements a simple dynamic array template used in CML	566
CML_Can.h	
This file contains the base classes used to define the low level interface to the CAN network hardware	567
CML_CanOpen.h	
This header file defines the classes used for the top level of the CANopen network	569
CML_Copley.h	
This header file defines a generic Copley node type	571
CML_CopleyIO.h	
Standard CANopen I/O module support	572
CML_Error.h	
This file defines the top level error class used throughout the library	576
CML_EtherCAT.h	
This header file defines the classes used to represent the top level of the EtherCAT network interface	577
CML_EventMap.h	
This file defines the Event Map class	579
CML_File.h	
This file holds various handy functions for parsing files	581
CML_Filter.h	
This file defines the Filter object	582
CML_Firmware.h	
This file defines classes related to the Copley amplifier Firmware object	583
CML_Geometry.h	
This file contains class definitions used to define multi-axis trajectory paths	585
CML_InputShaper.h	
This file defines the InputShaper object	586
CML_IO.h	
Standard CANopen I/O module support	587
CML_Linkage.h	
This file defines the Linkage object	593
CML_Network.h	
This header file defines the classes used for the generic top level network interface	595
CML_Node.h	
This header file defines the classes that define a generic node on the network	598
CML_PDO.h	
This header file defines the classes used to communicate to CANopen nodes using Process Data Objects (PDOs)	599
CML_Reference.h	
This header file defines a set of classes used to handle reference counting within the CML library	601
CML_SDO.h	
This header file defines the classes used to communicate to CANopen nodes using Service Data Objects (SDOs)	603
CML_Settings.h	
This file provides some configuration options used to customize the Copley Motion Libraries	605

CML_Threads.h	The classes defined in this file provide an operating system independent way of accessing multi-tasking system features	609
CML_Trajectory.h	611
CML_TrjScurve.h	This file defines the TrjScurve class	612
CML_Utils.h	This file holds various handy utility types and functions	613
CopleyIO.cpp	This file contains the CopleyIO object methods used to upload / download structures containing groups of module parameters	616
CopleyNode.cpp	This file holds code to implement the CopleyNode object	616
ecatdc.cpp	This file holds some utility code used by the EtherCAT network when initializing it's distributed clock	617
Error.cpp	This file handles initializing the static data objects used by the Error class	617
EtherCAT.cpp	This file holds code for the top level EtherCAT class	618
EventMap.cpp	This file contains the implementation of the EventMap class	618
File.cpp	This file contains code used to parse CME-2 type files	619
Filter.cpp	Implementation of the Filter class	619
Firmware.cpp	621
Geometry.cpp	622
InputShaper.cpp	Implementation of the InputShaper class	622
IOmodule.cpp	I/O module object support	622
Linkage.cpp	Implementation of the Linkage class	623
Network.cpp	This file holds code for the top level CANopen class	624
Node.cpp	This file holds code to implement the CANopen node related objects	624
PDO.cpp	This file holds the code needed to implement CANopen Process Data Objects (PDOs)	625
Reference.cpp	This file holds the code needed to implement the CML reference counting objects	625
SDO.cpp	This file contains the code used to implement the CANopen SDO objects	626
Threads.cpp	This file only contains definitions for the generic thread error objects	626

Chapter 5

Class Documentation

5.1 IOModule::AlInPDO Class Reference

Transmit [PDO](#) for mapping analog inputs.

Inheritance diagram for IOModule::AlInPDO:

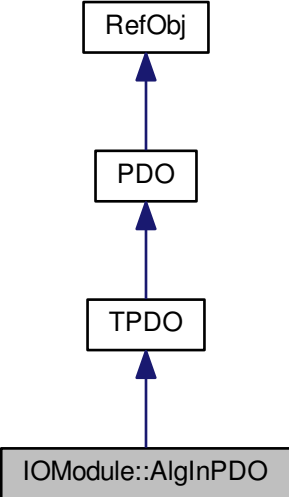

Collaboration diagram for IOModule::AlgInPDO:

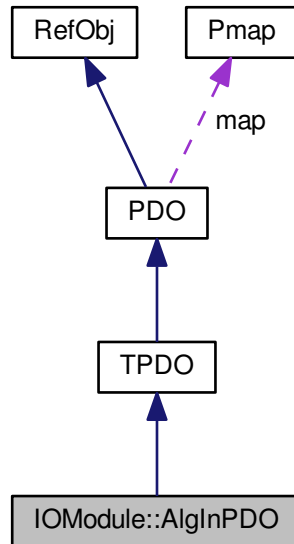

Public Member Functions

- const [Error](#) * [Init](#) (class [IOModule](#) *io, [uint32](#) cobID, [uint8](#) ct, [uint8](#) id[], [IOMODULE_EVENTS](#) event)
Initialize a analog input PDO object.
- bool [GetInVal](#) ([uint8](#) id, [int16](#) &value)
Read the specified input from the PDO's cached data.
- void [Received](#) (void)
New transmit PDO received.

Additional Inherited Members

5.1.1 Detailed Description

Transmit [PDO](#) for mapping analog inputs.

This class represents the standard transmit [PDO](#) which can be used to map up to 4 16-bit analog inputs.

5.1.2 Member Function Documentation

5.1.2.1 bool GetInVal (uint8 id, int16 & value)

Read the specified input from the [PDO](#)'s cached data.

The value returned will be the last value received via [PDO](#) for this input bank.

Parameters

<i>id</i>	The input ID to be checked.
<i>value</i>	The input value will be returned here. If the input is not mapped to this PDO , then this will not be changed.

Returns

true if the value was returned, false if the input isn't mapped to this [PDO](#).

5.1.2.2 `const Error * Init (class IOModule * io, uint32 cobID, uint8 ct, uint8 id[], IOMODULE_EVENTS event)`

Initialize a analog input [PDO](#) object.

Parameters

<i>io</i>	Pointer to the I/O module to which this PDO is assigned.
<i>cobID</i>	The CAN ID for this PDO message.
<i>ct</i>	The number of inputs to be mapped (1 to 4)
<i>id</i>	An array of ct input ID numbers. These will be mapped (in order) to the PDO .
<i>event</i>	The event bit to post when a PDO message is received.

Returns

A pointer to an error object, or NULL on success

5.1.2.3 `void Received (void) [virtual]`

New transmit [PDO](#) received.

This method is called by the CANopen reader thread when a new [PDO](#) message is received. It causes this [PDO](#) object to post it's event to the [IOModule](#) object's event map. This will cause any waiting threads to wake up.

Reimplemented from [TPDO](#).

The documentation for this class was generated from the following files:

- [CML_IO.h](#)
- [IOModule.cpp](#)

5.2 AlgoPhaseInit Struct Reference

Configuration structure used to set up algorithmic phase init.

Public Member Functions

- [AlgoPhaseInit](#) (void)

Default constructor.

Public Attributes

- [uint16 phaseInitCurrent](#)

Maximum Current to use with algorithmic phase initialization. (0.01 amp units)

- [uint16 phaseInitTime](#)

Algorithmic phase initialization timeout. (milliseconds)

- [uint16 phaseInitConfig](#)

Algorithmic Phase Initialization config.

5.2.1 Detailed Description

Configuration structure used to set up algorithmic phase init.

These settings may be up/download from the amplifier using the functions [Amp::SetAlgoPhaseInit](#) and [Amp::GetAlgoPhaseInit](#).

5.2.2 Constructor & Destructor Documentation

5.2.2.1 `AlgoPhaseInit(void)` `[inline]`

Default constructor.

Initializes all structure elements to zero.

5.2.3 Member Data Documentation

5.2.3.1 `uint16 phaseInitConfig`

Algorithmic Phase Initialization config.

Bit mapped as follows (Bit 0 If clear, use algorithmic phase initialization. If set force the phase angle to 0. bits 1 - 15 reserved)

The documentation for this struct was generated from the following file:

- [CML_AmpStruct.h](#)

5.3 IOModule::AlgOutPDO Class Reference

Receive [PDO](#) for mapping analog outputs.

Inheritance diagram for IOModule::AlgOutPDO:

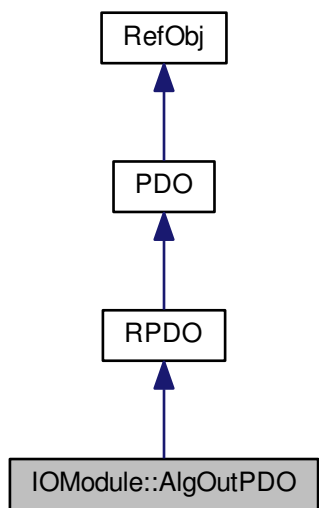

Collaboration diagram for IOModule::AlgOutPDO:

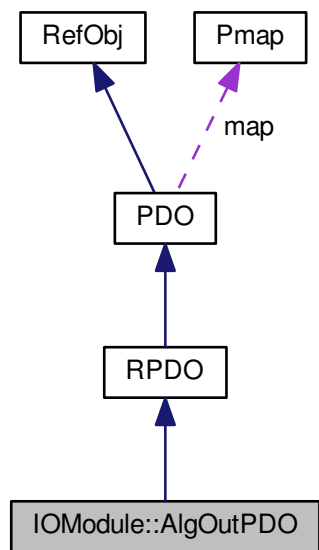

Public Member Functions

- `const Error * Init (class IOModule *io, uint32 cobID, uint8 ct, uint8 id[])`
Initialize an analog output PDO object.
- `bool Update (uint8 id, int16 value)`
Update the locally stored value of one of the 16-bit analog outputs associated with this PDO.
- `const Error * Transmit (void)`
Transmit this PDO.

Additional Inherited Members

5.3.1 Detailed Description

Receive PDO for mapping analog outputs.

This class represents the standard receive PDO which can be used to transmit up to 4 16-bit analog outputs.

5.3.2 Member Function Documentation

5.3.2.1 `const Error * Init (class IOModule * io, uint32 cobID, uint8 ct, uint8 id[])`

Initialize an analog output PDO object.

Parameters

<i>io</i>	Pointer to the I/O module to which this PDO is assigned.
<i>cobID</i>	The CAN ID for this PDO message.
<i>ct</i>	The number of outputs to be mapped (1 to 4)
<i>id</i>	An array of ct output ID numbers. These will be mapped (in order) to the PDO.

Returns

A pointer to an error object, or NULL on success

5.3.2.2 `const Error * Transmit (void)`

Transmit this PDO.

Returns

A pointer to an error object, or NULL on success

5.3.2.3 `bool Update (uint8 id, int16 value)`

Update the locally stored value of one of the 16-bit analog outputs associated with this PDO.

Parameters

<i>id</i>	The output block ID to be updated.
<i>value</i>	The new value for the output block.

Returns

true if the value was updated, false if the block isn't mapped to this [PDO](#).

The documentation for this class was generated from the following files:

- [CML_IO.h](#)
- [IOmodule.cpp](#)

5.4 Amp Class Reference

Copley Controls amplifier object.

Inheritance diagram for Amp:

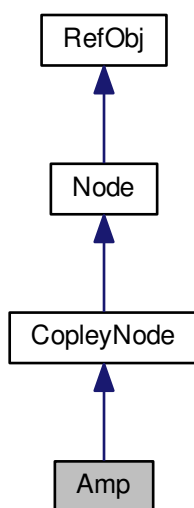

Collaboration diagram for Amp:

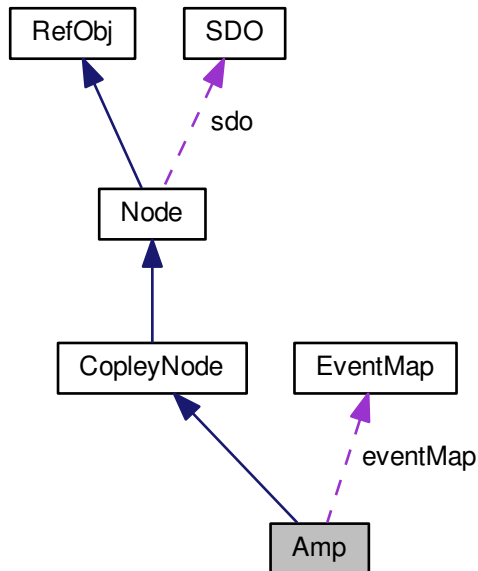

Public Member Functions

- const [Error](#) * [UpdateEvents](#) ([uint16](#) stat, [uint32](#) events, [uint16](#) inputs)
Update the amplifier's event map based on the status information received by a status [PDO](#).
- void [PvtStatusUpdate](#) ([uint32](#) status)
This function is called by the PVT status [PDO](#) receiver function.
- virtual [uint32](#) [GetNetworkRef](#) (void)
Return a reference ID to the network that this node is attached to.
- virtual [NodeState](#) [GetState](#) (void)
Returns the present state of this node.
- const [Error](#) * [GetStatusWord](#) ([uint16](#) &value)
Get the current value of the drive's status word.
- const [Error](#) * [SetControlWord](#) ([uint16](#) value)
Set the amplifier's control word.
- const [Error](#) * [GetControlWord](#) ([uint16](#) &value)
Returns the present value of the CANopen device profile control word.

Amplifier initialization

- [Amp](#) ()
Default constructor.
- [Amp](#) ([Network](#) &net, [int16](#) nodeID)
Construct and initialize an amplifier object using defaults for all amp settings.

- [Amp](#) ([Network](#) &net, [int16](#) nodeID, [AmpSettings](#) &settings)
Construct and initialize an amplifier object.
- virtual [~Amp](#) ()
Amp object destructor.
- const [Error](#) * [Init](#) ([Network](#) &net, [int16](#) nodeID)
Initialize the amplifier object using all default settings.
- const [Error](#) * [Init](#) ([Network](#) &net, [int16](#) nodeID, [AmpSettings](#) &settings)
Initialize the amplifier object with custom amp settings.
- const [Error](#) * [ReInit](#) (void)
Re-initialize an amplifier.
- const [Error](#) * [Reset](#) (void)
Reset the amplifier object.
- const [Error](#) * [InitSubAxis](#) ([Amp](#) &primary, int axis=2)
Initialize an [Amp](#) object for use with a secondary axis of a multi-axis [EtherCAT](#) amplifier.

Amplifier modes & status info

- const [Error](#) * [GetAmpName](#) (char *name)
Get the amplifier name stored in the amplifiers flash.
- const [Error](#) * [SetAmpName](#) (char *name)
Set the amplifier name stored in the amplifiers flash.
- const [Error](#) * [SetAmpMode](#) ([AMP_MODE](#) mode)
Set the amplifier mode of operation.
- const [Error](#) * [GetAmpMode](#) ([AMP_MODE](#) &mode)
Get the currently active amplifier mode of operation.
- const [Error](#) * [Disable](#) (bool wait=true)
Disable the amplifier.
- const [Error](#) * [Enable](#) (bool wait=true)
Enable the amplifier.
- bool [IsHardwareEnabled](#) (void)
Return true if the amplifier's PWM outputs are currently enabled.
- bool [IsSoftwareEnabled](#) (void)
Return true if the amplifier is being enabled by software.
- bool [IsReferenced](#) (void)
Return true if the amplifier has been successfully referenced (homed).
- const [Error](#) * [CheckStateForMove](#) (void)
Check the amplifier's state to make sure a move can be started.
- const [Error](#) * [ClearFaults](#) (void)
Clear amplifier faults.
- const [Error](#) * [GetFaults](#) ([AMP_FAULT](#) &value)
Get any active amplifier faults.
- const [Error](#) * [SetFaultMask](#) ([AMP_FAULT](#) &value)
Set the amplifier's fault mask.
- const [Error](#) * [GetFaultMask](#) ([AMP_FAULT](#) &value)
Get the current value of the amplifier's fault mask.
- const [Error](#) * [GetEventStatus](#) ([EVENT_STATUS](#) &stat)
Get the amplifier's 'event status' register.
- const [Error](#) * [GetEventSticky](#) ([EVENT_STATUS](#) &stat)
Get the amplifier's 'sticky' event status register.
- const [Error](#) * [GetEventLatch](#) ([EVENT_STATUS](#) &stat)
Get the amplifier's latched event status register.
- const [Error](#) * [SetPwmMode](#) ([AMP_PWM_MODE](#) mode)
Set the PWM output mode configuration for the amplifier.
- const [Error](#) * [GetPwmMode](#) ([AMP_PWM_MODE](#) &mode)

- Get the current PWM output mode configuration from the amplifier.*

 - const [Error](#) * [SetPhaseMode](#) ([AMP_PHASE_MODE](#) mode)

Set the phasing mode configuration for the amplifier.

 - const [Error](#) * [GetPhaseMode](#) ([AMP_PHASE_MODE](#) &mode)

Get the current phasing mode configuration from the amplifier.

Motor & Amplifier state information

- const [Error](#) * [GetPositionActual](#) (uunit &value)
 - Get the actual position used by the servo loop.*
- const [Error](#) * [SetPositionActual](#) (uunit value)
 - Set the actual position.*
- const [Error](#) * [GetPositionMotor](#) (uunit &value)
 - Get the actual motor position.*
- const [Error](#) * [SetPositionMotor](#) (uunit value)
 - Set the actual motor position.*
- const [Error](#) * [GetPositionLoad](#) (uunit &value)
 - Get the load encoder position.*
- const [Error](#) * [SetPositionLoad](#) (uunit value)
 - Set the load encoder position.*
- const [Error](#) * [GetPositionCommand](#) (uunit &value)
 - Get the instantaneous commanded position.*
- const [Error](#) * [GetPositionError](#) (uunit &value)
 - Get the position error.*
- const [Error](#) * [GetVelocityActual](#) (uunit &value)
 - Get the actual motor velocity.*
- const [Error](#) * [GetVelocityLoad](#) (uunit &value)
 - Get the load encoder velocity.*
- const [Error](#) * [GetVelocityCommand](#) (uunit &value)
 - Get the commanded velocity.*
- const [Error](#) * [GetVelocityLimited](#) (uunit &value)
 - Get the limited velocity.*
- const [Error](#) * [GetCurrentActual](#) (int16 &value)
 - Get the actual motor current.*
- const [Error](#) * [GetCurrentCommand](#) (int16 &value)
 - Get the commanded motor current.*
- const [Error](#) * [GetCurrentLimited](#) (int16 &value)
 - Get the limited motor current.*
- const [Error](#) * [GetTrajectoryVel](#) (uunit &value)
 - Get the instantaneous commanded velocity passed out of the trajectory generator.*
- const [Error](#) * [GetTrajectoryAcc](#) (uunit &value)
 - Get the instantaneous commanded acceleration passed out of the trajectory generator.*
- const [Error](#) * [GetPhaseAngle](#) (int16 &value)
 - Get the motor phase angle.*
- const [Error](#) * [GetHallState](#) (int16 &value)
 - Get the current digital hall sensor state.*
- const [Error](#) * [GetRefVoltage](#) (int16 &value)
 - Get the analog reference input voltage.*
- const [Error](#) * [GetHighVoltage](#) (int16 &value)
 - Get the high voltage bus voltage in units of 0.1 volts.*
- const [Error](#) * [GetAmpTemp](#) (int16 &value)
 - Get the current amplifier temperature (degrees C).*
- const [Error](#) * [GetAnalogEncoder](#) (int16 &sin, int16 &cos)
 - Get the raw voltage on the two analog encoder inputs (0.1 millivolt units).*
- const [Error](#) * [GetMotorCurrent](#) (int16 &u, int16 &v)

Get the actual current values read directly from the amplifier's current sensors.

Input & Output pin control

- const **Error** * **SetIoConfig** (**AmpIoCfg** &cfg)
Configure the amplifier's programmable I/O pins using the values passed in the config structure.
- const **Error** * **GetIoConfig** (**AmpIoCfg** &cfg)
Read the amplifier's programmable I/O pin configuration and return it in the passed config structure.
- const **Error** * **GetInputs** (**uint16** &value, bool viaSDO=false)
Get the present value of the general purpose input pins.
- const **Error** * **GetInputs32** (**uint32** &value)
32-bit version to Get the present value of the general purpose input pins.
- const **Error** * **WaitInputEvent** (**Event** &e, **Timeout** timeout, **uint32** &match)
Wait on the amplifier's general purpose input pins.
- const **Error** * **WaitInputHigh** (**uint32** inputs, **Timeout** timeout=-1)
Wait for any of the specified general purpose input pins to be set.
- const **Error** * **WaitInputLow** (**uint32** inputs, **Timeout** timeout=-1)
Wait for any of the specified general purpose input pins to be lowered.
- const **Error** * **SetIoPullup** (**uint16** value)
Set the current state of the input pin pull up/down resistors.
- const **Error** * **GetIoPullup** (**uint16** &value)
Get the current state of the input pin pull up/down resistors.
- const **Error** * **SetInputConfig** (**int8** pin, **INPUT_PIN_CONFIG** cfg, **uint16** axis=0)
Set the input pin configuration for the specified input pin.
- const **Error** * **GetInputConfig** (**int8** pin, **INPUT_PIN_CONFIG** &cfg)
Get the input pin configuration for the specified input pin.
- const **Error** * **GetInputConfig** (**int8** pin, **INPUT_PIN_CONFIG** &cfg, **uint16** &axis)
Get the input pin configuration for the specified input pin.
- const **Error** * **SetInputDebounce** (**int8** pin, **int16** value)
Set the input pin debounce time for the specified input pin.
- const **Error** * **GetInputDebounce** (**int8** pin, **int16** &value)
Get the input pin debounce time for the specified input pin.
- const **Error** * **SetOutputConfig** (**int8** pin, **OUTPUT_PIN_CONFIG** cfg, **uint32** mask1=0, **uint32** mask2=0, **uint16** axis=0)
Set the output pin configuration for the specified pin.
- const **Error** * **GetOutputConfig** (**int8** pin, **OUTPUT_PIN_CONFIG** &cfg)
Get the output configuration for the specified pin.
- const **Error** * **GetOutputConfig** (**int8** pin, **OUTPUT_PIN_CONFIG** &cfg, **uint16** &axis)
Get the output configuration for the specified pin.
- const **Error** * **GetOutputConfig** (**int8** pin, **OUTPUT_PIN_CONFIG** &cfg, **uint32** &mask)
Get the output pin configuration for the specified pin.
- const **Error** * **GetOutputConfig** (**int8** pin, **OUTPUT_PIN_CONFIG** &cfg, **uint32** &mask, **uint16** &axis)
Get the output pin configuration for the specified pin.
- const **Error** * **GetOutputConfig** (**int8** pin, **OUTPUT_PIN_CONFIG** &cfg, **uint32** &mask1, **uint32** &mask2)
Get the output pin configuration for the specified pin.
- const **Error** * **GetOutputConfig** (**int8** pin, **OUTPUT_PIN_CONFIG** &cfg, **uint32** &mask1, **uint32** &mask2, **uint16** &axis)
Get the output pin configuration for the specified pin.
- const **Error** * **SetOutputs** (**uint16** value)
Update the state of the manual output pins.
- const **Error** * **GetOutputs** (**uint16** &value)
Get the present value of the output pin control register.
- const **Error** * **SetIOOptions** (**int32** value)
Set the IO Options.
- const **Error** * **GetIOOptions** (**int32** &value)

Get the IO Options.

- const [Error](#) * [SetIoPullup32](#) (int32 value)
32 Bit version of SetIoPullup.
- const [Error](#) * [GetIoPullup32](#) (int32 &value)
32 Bit version of GetIoPullup.

Position capture

- const [Error](#) * [SetPosCaptureCfg](#) (POS_CAPTURE_CFG cfg)
Set the position capture configuration.
- const [Error](#) * [GetPosCaptureCfg](#) (POS_CAPTURE_CFG &cfg)
Read the current configuration of the position capture mechanism.
- const [Error](#) * [GetPosCaptureStat](#) (POS_CAPTURE_STAT &stat)
Read the current status of the position capture mechanism.
- const [Error](#) * [GetIndexCapture](#) (int32 &value)
Get the most recently captured encoder index position.
- const [Error](#) * [GetHomeCapture](#) (int32 &value)
Get the most recently captured home sensor position.

General parameter setup.

- const [Error](#) * [GetAmpConfig](#) (AmpConfig &cfg)
Read the complete amplifier configuration from the amplifier and return it in the passed structure.
- const [Error](#) * [SetAmpConfig](#) (AmpConfig &cfg)
Update an amplifier's configuration from the passed structure.
- const [Error](#) * [SaveAmpConfig](#) (AmpConfig &cfg)
Upload the passed amplifier configuration to the amplifier's workign memory, and then copy that working memory to flash.
- const [Error](#) * [SaveAmpConfig](#) (void)
Save all amplifier parameters to internal flash memory.
- const [Error](#) * [LoadFromFile](#) (const char *name, int &line)
Load the specified amplifier data file.
- const [Error](#) * [GetCanNetworkConfig](#) (CanNetworkConfig &cfg)
Get the current CANopen network configuration programmed into the amplifier.
- const [Error](#) * [SetCanNetworkConfig](#) (CanNetworkConfig &cfg)
Set the CANopen node ID and bit rate configuration.
- const [Error](#) * [GetNetworkOptions](#) (NetworkOptions &cfg)
Set the [Network Options](#) configuration.
- const [Error](#) * [SetNetworkOptions](#) (NetworkOptions &cfg)
Set the [Network Options](#) configuration.
- const [Error](#) * [GetAmpInfo](#) (AmpInfo &info)
Read the Amplifier information parameters from the drive.
- const [Error](#) * [GetMtrInfo](#) (MtrInfo &info)
Read the motor information structure from the amplifier.
- const [Error](#) * [SetMtrInfo](#) (MtrInfo &info)
Update the amplifier's motor information.
- const [Error](#) * [GetRegenConfig](#) (RegenConfig &cfg)
Upload the current configuration parameters for the power regeneration resister connected to the amplifier.
- const [Error](#) * [SetRegenConfig](#) (RegenConfig &cfg)
Download a new configuration structure for the power regeneration resister.
- const [Error](#) * [GetUstepConfig](#) (UstepConfig &cfg)
Upload the current configuration parameters for the stepper.
- const [Error](#) * [SetUstepConfig](#) (UstepConfig &cfg)
Download a new configuration structure for the microstepper.
- const [Error](#) * [GetAlgoPhaseInit](#) (AlgoPhaseInit &cfg)

- *Upload the current configuration parameters for the algorithmic phase init.*
const [Error](#) * [SetAlgoPhaseInit](#) ([AlgoPhaseInit](#) &cfg)
- *Download a new configuration structure for the algorithmic phase init.*
const [Error](#) * [GetCammingConfig](#) ([CammingConfig](#) &cfg)
- *Upload the current configuration parameters for the camming.*
const [Error](#) * [SetCammingConfig](#) ([CammingConfig](#) &cfg)
- *Download a new configuration structure for Camming.*
const [Error](#) * [GetGainScheduling](#) ([GainScheduling](#) &cfg)
- *Upload the current configuration parameters for the GainS cheduling.*
const [Error](#) * [SetGainScheduling](#) ([GainScheduling](#) &cfg)
- *Download a new configuration structure for Gain Scheduling.*
const [Error](#) * [GetDAConverterConfig](#) ([DAConfig](#) &cfg)
- *Get the configuration for the D/A converter.*
const [Error](#) * [SetDAConverterConfig](#) ([DAConfig](#) &cfg)
- *Set the D/A converter configuration.*

Low level access to CANopen objects.

- const [Error](#) * [Download](#) (int16 index, int16 sub, int32 size, byte *data)
Download data to an object in this Amps object dictionary.
- const [Error](#) * [Uplod](#) (int16 index, int16 sub, int32 &size, byte *data)
Upload data from an object in this Amps object dictionary.
- const [Error](#) * [Dnld32](#) (int16 index, int16 sub, uint32 data)
Download data to an object in this Amps object dictionary.
- const [Error](#) * [Dnld32](#) (int16 index, int16 sub, int32 data)
Download data to an object in this Amps object dictionary.
- const [Error](#) * [Upld32](#) (int16 index, int16 sub, uint32 &data)
Upload data from an object in this Amps object dictionary.
- const [Error](#) * [Upld32](#) (int16 index, int16 sub, int32 &data)
Upload data from an object in this Amps object dictionary.
- const [Error](#) * [Dnld16](#) (int16 index, int16 sub, uint16 data)
Download data to an object in this Amps object dictionary.
- const [Error](#) * [Dnld16](#) (int16 index, int16 sub, int16 data)
Download data to an object in this Amps object dictionary.
- const [Error](#) * [Upld16](#) (int16 index, int16 sub, uint16 &data)
Upload data from an object in this Amps object dictionary.
- const [Error](#) * [Upld16](#) (int16 index, int16 sub, int16 &data)
Upload data from an object in this Amps object dictionary.
- const [Error](#) * [Dnld8](#) (int16 index, int16 sub, uint8 data)
Download data to an object in this Amps object dictionary.
- const [Error](#) * [Dnld8](#) (int16 index, int16 sub, int8 data)
Download data to an object in this Amps object dictionary.
- const [Error](#) * [Upld8](#) (int16 index, int16 sub, uint8 &data)
Upload data from an object in this Amps object dictionary.
- const [Error](#) * [Upld8](#) (int16 index, int16 sub, int8 &data)
Upload data from an object in this Amps object dictionary.
- const [Error](#) * [DnldString](#) (int16 index, int16 sub, char *data)
Download data to an object in this Amps object dictionary.
- const [Error](#) * [UpldString](#) (int16 index, int16 sub, int32 &len, char *data)
Upload data from an object in this Amps object dictionary.

Control loop setup

- const [Error](#) * [GetPosLoopConfig](#) ([PosLoopConfig](#) &cfg)

- Get the configuration values of the amplifiers position loop.*
- const [Error](#) * [SetPosLoopConfig](#) ([PosLoopConfig](#) &cfg)
- Update the amplifier's position loop configuration.*
- const [Error](#) * [GetVelLoopConfig](#) ([VelLoopConfig](#) &cfg)
- Get the configuration values of the amplifiers velocity loop.*
- const [Error](#) * [SetVelLoopConfig](#) ([VelLoopConfig](#) &cfg)
- Update the amplifier's velocity loop configuration.*
- const [Error](#) * [GetCrntLoopConfig](#) ([CrntLoopConfig](#) &cfg)
- Get the configuration values of the amplifiers current loop.*
- const [Error](#) * [SetCrntLoopConfig](#) ([CrntLoopConfig](#) &cfg)
- Update the amplifier's current loop configuration.*
- const [Error](#) * [GetVloopOutputFilter](#) ([Filter](#) &f)
- Get the coefficients used in the velocity loop output filter.*
- const [Error](#) * [SetVloopOutputFilter](#) ([Filter](#) &f)
- Set new coefficients for the velocity loop output filter.*
- const [Error](#) * [GetVloopOutputFilter2](#) ([Filter](#) &f)
- Get the coefficients used in the second velocity loop output filter.*
- const [Error](#) * [SetVloopOutputFilter2](#) ([Filter](#) &f)
- Set the coefficients used in the second velocity loop output filter.*
- const [Error](#) * [GetVloopOutputFilter3](#) ([Filter](#) &f)
- Get the coefficients used in the third velocity loop output filter.*
- const [Error](#) * [SetVloopOutputFilter3](#) ([Filter](#) &f)
- Set the coefficients used in the third velocity loop output filter.*
- const [Error](#) * [GetVloopCommandFilter](#) ([Filter](#) &f)
- Get the coefficients used in the velocity loop command filter.*
- const [Error](#) * [SetVloopCommandFilter](#) ([Filter](#) &f)
- Set new coefficients for the velocity loop command filter.*
- const [Error](#) * [GetIloopCommandFilter](#) ([Filter](#) &f)
- Get the coefficients used in the current loop input filter.*
- const [Error](#) * [SetIloopCommandFilter](#) ([Filter](#) &f)
- Set the coefficients used in the current loop input filter.*
- const [Error](#) * [GetIloopCommandFilter2](#) ([Filter](#) &f)
- Get the coefficients used in the second current loop input filter.*
- const [Error](#) * [SetIloopCommandFilter2](#) ([Filter](#) &f)
- Set the coefficients used in the second current loop input filter.*
- const [Error](#) * [GetAnalogCommandFilter](#) ([Filter](#) &f)
- Get the coefficients used in the velocity loop command filter.*
- const [Error](#) * [SetAnalogCommandFilter](#) ([Filter](#) &f)
- Set new coefficients for the analog reference input filter.*
- const [Error](#) * [GetInputShapingFilter](#) ([InputShaper](#) &f)
- Get the coefficients used in the input shaping filter.*
- const [Error](#) * [SetInputShapingFilter](#) ([InputShaper](#) &f)
- Set new coefficients for the input shaping filter.*

Position and velocity windows

- const [Error](#) * [SetTrackingWindows](#) ([TrackingWindows](#) &cfg)
- Update the amplifier's tracking window configuration.*
- const [Error](#) * [GetTrackingWindows](#) ([TrackingWindows](#) &cfg)
- Get the configuration values of the amplifiers position & velocity tracking windows.*
- const [Error](#) * [SetPositionErrorWindow](#) (uunit value)
- Set the position error window.*
- const [Error](#) * [GetPositionErrorWindow](#) (uunit &value)
- Get the position error window.*
- const [Error](#) * [SetPositionWarnWindow](#) (uunit value)

- Set the position warning window.*

 - const **Error** * **GetPositionWarnWindow** (uunit &value)
- Get the position warning window.*

 - const **Error** * **SetSettlingWindow** (uunit value)
- Set the position settling window.*

 - const **Error** * **GetSettlingWindow** (uunit &value)
- Get the position window value.*

 - const **Error** * **SetSettlingTime** (uint16 value)
- Set the position window time value (milliseconds).*

 - const **Error** * **GetSettlingTime** (uint16 &value)
- Get the position window time value (milliseconds).*

 - const **Error** * **SetVelocityWarnWindow** (uunit value)
- Set the velocity warning window.*

 - const **Error** * **GetVelocityWarnWindow** (uunit &value)
- Get the velocity warning window.*

 - const **Error** * **SetVelocityWarnTime** (uint16 value)
- Set the velocity warning window time value (milliseconds).*

 - const **Error** * **GetVelocityWarnTime** (uint16 &value)
- Get the position window time value (milliseconds).*

 - const **Error** * **SetSoftLimits** (SoftPosLimit &cfg)
- Set software limit switch settings.*

 - const **Error** * **GetSoftLimits** (SoftPosLimit &cfg)
- Upload the current software limit switch settings from the amplifier.*

Homing mode.

- const **Error** * **GoHome** (void)

Execute a home move.
- const **Error** * **GoHome** (HomeConfig &cfg)

Execute a home move.
- const **Error** * **SetHomeConfig** (HomeConfig &cfg)

Configure the amplifier's homing related parameters.
- const **Error** * **GetHomeConfig** (HomeConfig &cfg)

Load a structure with all parameters related to homing the amplifier.
- const **Error** * **SetHomeMethod** (COPLY_HOME_METHOD method, uint16 extended=0)

Set the method used for homing the drive.
- const **Error** * **GetHomeMethod** (COPLY_HOME_METHOD &method, uint16 *extended=0)

Get the selected homing method.
- const **Error** * **SetHomeOffset** (uunit value)

Set the home offset value.
- const **Error** * **GetHomeOffset** (uunit &value)

Get the home offset value.
- const **Error** * **SetHomeVelFast** (uunit value)

Set the home velocity used to move to a home switch.
- const **Error** * **GetHomeVelFast** (uunit &value)

Get the home velocity used to move to a home switch.
- const **Error** * **SetHomeVelSlow** (uunit value)

Set the home velocity used to find a switch edge.
- const **Error** * **GetHomeVelSlow** (uunit &value)

Get the home velocity used to find a switch edge.
- const **Error** * **SetHomeAccel** (uunit value)

Set the home acceleration.
- const **Error** * **GetHomeAccel** (uunit &value)

Get the home acceleration.
- const **Error** * **SetHomeCurrent** (int16 value)

- Set the home current.*
 • const [Error](#) * [GetHomeCurrent](#) (int16 &value)
- Get the home current.*
 • const [Error](#) * [SetHomeDelay](#) (int16 value)
- Set the home delay.*
 • const [Error](#) * [GetHomeDelay](#) (int16 &value)
- Get the home current.*
 • const [Error](#) * [GetHomeAdjustment](#) (uunit &value)
- Get the last home adjustment amount.*

Quick stop support

- const [Error](#) * [QuickStop](#) (void)
Perform a 'quick stop' on the axis.
- const [Error](#) * [HaltMove](#) (void)
Halt the current move.
- const [Error](#) * [SetQuickStopDec](#) (uunit value)
Set the quick stop deceleration value (i.e.
- const [Error](#) * [GetQuickStopDec](#) (uunit &value)
Get the quick stop deceleration value.
- const [Error](#) * [SetHaltMode](#) (HALT_MODE mode)
Set the halt mode.
- const [Error](#) * [GetHaltMode](#) (HALT_MODE &mode)
Get the halt mode.
- const [Error](#) * [SetQuickStop](#) (QUICK_STOP_MODE mode)
Set the quick stop mode.
- const [Error](#) * [GetQuickStop](#) (QUICK_STOP_MODE &mode)
Get the quick stop mode.

Point to point move support (position profile mode)

- const [Error](#) * [SetupMove](#) (ProfileConfigTrap &cfg)
Setup a point to point move, but do not start it.
- const [Error](#) * [SetupMove](#) (ProfileConfigScurve &cfg)
Setup a point to point move, but do not start it.
- const [Error](#) * [SetupMove](#) (ProfileConfigVel &cfg)
Setup a point to point move, but do not start it.
- const [Error](#) * [DoMove](#) (ProfileConfigTrap &cfg, bool relative=false)
Perform a point to point move.
- const [Error](#) * [DoMove](#) (ProfileConfigScurve &cfg, bool relative=false)
Perform a point to point move.
- const [Error](#) * [DoMove](#) (ProfileConfigVel &cfg)
Perform a velocity profile move.
- const [Error](#) * [DoMove](#) (uunit pos, bool relative=false)
Perform a point to point move.
- const [Error](#) * [StartMove](#) (bool relative=false)
Start the move that's already been programmed.
- const [Error](#) * [MoveAbs](#) (uunit pos)
Start an absolute point to point move to the specified position.
- const [Error](#) * [MoveRel](#) (uunit dist)
Start a relative point to point move of the specified distance.
- const [Error](#) * [SetProfileConfig](#) (ProfileConfig &cfg)
Configure the amplifier's parameters related to point-to-point moves.
- const [Error](#) * [GetProfileConfig](#) (ProfileConfig &cfg)

- Load a structure with all parameters related to point-to-point moves.*

 - const **Error** * **SetProfileType** (PROFILE_TYPE type)
 - Set the motion profile type.*
 - const **Error** * **GetProfileType** (PROFILE_TYPE &type)
 - Get the currently selected motion profile type.*
 - const **Error** * **SetTargetPos** (uunit value)
 - Set the profile target position (i.e.*
 - const **Error** * **GetTargetPos** (uunit &value)
 - Get the profile target position.*
 - const **Error** * **SetProfileVel** (uunit value)
 - Set the profile velocity value (i.e.*
 - const **Error** * **GetProfileVel** (uunit &value)
 - Get the profile velocity value.*
 - const **Error** * **SetProfileAcc** (uunit value)
 - Set the profile acceleration value (i.e.*
 - const **Error** * **GetProfileAcc** (uunit &value)
 - Get the profile acceleration value.*
 - const **Error** * **SetProfileDec** (uunit value)
 - Set the profile deceleration value (i.e.*
 - const **Error** * **GetProfileDec** (uunit &value)
 - Get the profile deceleration value.*
 - const **Error** * **SetProfileJerk** (uunit value)
 - Set the jerk limit used with S-curve profiles.*
 - const **Error** * **GetProfileJerk** (uunit &value)
 - Get the currently programmed jerk limit for S-curve profiles.*

Profile velocity mode support

- const **Error** * **SetTargetVel** (uunit value)
- Set the target velocity used in profile velocity mode.*
- const **Error** * **GetTargetVel** (uunit &value)
- Get the target velocity used in profile velocity mode.*

Profile torque mode support

- const **Error** * **SetTorqueTarget** (int16 value)
- Set the amplifier target torque value.*
- const **Error** * **GetTorqueTarget** (int16 &value)
- Get the current target torque value.*
- const **Error** * **GetTorqueDemand** (int16 &value)
- Get the torque demand value.*
- const **Error** * **GetTorqueActual** (int16 &value)
- Get the actual torque being applied by the motor at the moment.*
- const **Error** * **SetTorqueSlope** (int32 value)
- Set the rate of change of torque for use in profile torque mode (AMPMODE_CAN_TORQUE).*
- const **Error** * **GetTorqueSlope** (int32 &value)
- Get the rate of change of torque for use in profile torque mode (AMPMODE_CAN_TORQUE).*
- const **Error** * **SetTorqueRated** (int32 value)
- Set the motor rated torque parameter.*
- const **Error** * **GetTorqueRated** (int32 &value)
- Get the motor rated torque parameter.*

PVT (interpolated position) trajectory support

- const [Error](#) * [SendTrajectory](#) ([Trajectory](#) &trj, bool start=true)
Upload a PVT move trajectory to the amplifier and optionally start the move.
- const [Error](#) * [StartPVT](#) (void)
Start a PVT move that has already been uploaded.
- const [Error](#) * [GetPvtBuffFree](#) (int16 &n)
Get the number of free positions in the PVT segment buffer.
- const [Error](#) * [GetPvtSegID](#) (uint16 &id)
Get the segment ID that the amplifier expects for the next PVT segment.
- const [Error](#) * [GetPvtBuffStat](#) (uint32 &stat)
Get the amplifier's PVT buffer status word.
- const [Error](#) * [GetPvtSegPos](#) (uunit &pos)
Get the starting position of the PVT segment currently active in the amplifier.

Amplifier event processing

- const [Error](#) * [WaitEvent](#) ([Event](#) &e, Timeout timeout=-1)
Wait for an amplifier event condition.
- const [Error](#) * [WaitEvent](#) ([Event](#) &e, Timeout timeout, [AMP_EVENT](#) &match)
Wait for an amplifier event condition.
- const [Error](#) * [WaitMoveDone](#) (Timeout timeout=-1)
Wait for the currently running move to finish, or for an error to occur.
- const [Error](#) * [WaitHomeDone](#) (Timeout timeout=-1)
Wait for the currently running homing move to finish, or for an error to occur.
- const [Error](#) * [ClearNodeGuardEvent](#) (void)
This function attempts to clear a node guarding event condition.
- const [Error](#) * [GetEventMask](#) ([AMP_EVENT](#) &e)
Get the current state of the amplifier's event mask.
- const [Error](#) * [GetErrorStatus](#) (bool noComm=false)
Return an error object identifying the amplifiers status.

Unit conversion functions.

If unit conversions are enabled in [CML_Settings.h](#), then these functions handle the details of converting from user position, velocity, acceleration & jerk units to the internal units used by the amplifier.

- virtual const [Error](#) * [SetCountsPerUnit](#) (uunit cts)
Configure the user programmable units.
- virtual const [Error](#) * [GetCountsPerUnit](#) (uunit &cts)
Get the number of encoder counts / user distance unit.
- virtual const [Error](#) * [SetCountsPerUnit](#) (uunit load, uunit mtr)
Configure the user programmable units for a dual encoder system.
- virtual const [Error](#) * [GetCountsPerUnit](#) (uunit &load, uunit &mtr)
Get the number of encoder counts / user distance unit for both encoders in a dual encoder system.
- virtual [int32](#) [PosUser2Mtr](#) (uunit pos)
Convert a position from user position units to internal amplifier units.
- virtual [int32](#) [VelUser2Mtr](#) (uunit vel)
Convert a velocity from user units to internal amplifier units.
- virtual [int32](#) [AccUser2Mtr](#) (uunit vel)
Convert an acceleration from user units to internal amplifier units.
- virtual [uunit](#) [PosMtr2User](#) (int32 pos)
Convert a position from internal amplifier units to user units.
- virtual [uunit](#) [VelMtr2User](#) (int32 vel)
Convert a velocity from internal amplifier units to user units.
- virtual [uunit](#) [AccMtr2User](#) (int32 vel)
Convert an acceleration from internal amplifier units to user units.

- virtual [int32 PosUser2Load](#) ([uunit](#) pos)
Convert a position from user position units to internal amplifier units.
- virtual [int32 VelUser2Load](#) ([uunit](#) vel)
Convert a velocity from user units to internal amplifier units.
- virtual [int32 AccUser2Load](#) ([uunit](#) acc)
Convert an acceleration from user units to internal amplifier units.
- virtual [int32 JrkUser2Load](#) ([uunit](#) jrk)
Convert a jerk value from user units to internal amplifier units.
- virtual [uunit PosLoad2User](#) ([int32](#) pos)
Convert a position from internal amplifier units to user units.
- virtual [uunit VelLoad2User](#) ([int32](#) vel)
Convert a velocity from internal amplifier units to user units.
- virtual [uunit AccLoad2User](#) ([int32](#) acc)
Convert an acceleration from internal amplifier units to user units.
- virtual [uunit JrkLoad2User](#) ([int32](#) jrk)
Convert a jerk value from internal amplifier units to user units.

Linkage access

Amplifier object may be attached to a [Linkage](#) object.

In this case, multi- axis moves may be easily performed through calls to the [Linkage](#) object holding the amplifiers.

- class [Linkage](#) * [GetLinkage](#) (void)
Return a pointer to the linkage that this amplifier is attached to.
- [uint32 GetLinkRef](#) (void)
Return a reference to the linkage that this amplifier is attached to.

Non standard modes of operation.

These functions are used when running in modes other than the standard CANopen position modes.

Note that at present the libraries offer only very limited support for these modes.

- const [Error](#) * [GetFuncGenConfig](#) ([FuncGenConfig](#) &cfg)
Upload the current configuration of the amplifier's internal function generator.
- const [Error](#) * [SetFuncGenConfig](#) ([FuncGenConfig](#) &cfg)
Configure the amplifier's internal function generator.
- const [Error](#) * [GetAnalogRefConfig](#) ([AnalogRefConfig](#) &cfg)
Upload the amplifier's analog reference input configuration.
- const [Error](#) * [SetAnalogRefConfig](#) ([AnalogRefConfig](#) &cfg)
Configure the amplifier's analog reference input.
- const [Error](#) * [GetPwmInConfig](#) ([PwmInConfig](#) &cfg)
Upload the amplifier's PWM input pin configuration.
- const [Error](#) * [SetPwmInConfig](#) ([PwmInConfig](#) &cfg)
Configure the amplifier's PWM input pins.
- const [Error](#) * [SetCurrentProgrammed](#) ([int16](#) crnt)
Set the programmed current value in 0.01 Amp units.
- const [Error](#) * [GetCurrentProgrammed](#) ([int16](#) &crnt)
Get the programmed current value.
- const [Error](#) * [SetVelocityProgrammed](#) ([uunit](#) vel)
Set the programmed velocity value.
- const [Error](#) * [GetVelocityProgrammed](#) ([uunit](#) &vel)
Get the programmed velocity value.
- const [Error](#) * [SetMicrostepRate](#) ([int16](#) rate)
Set the amplifier microstepping rate.
- const [Error](#) * [GetMicrostepRate](#) ([int16](#) &rate)

Get the amplifier microstepping rate.

Trace control functions

The amplifier supports an internal 'tracing' mechanism which allows certain internal variables to be sampled at a fixed rate and stored to internal memory.

This mechanism is used by the CME program to implement the oscilloscope display of internal amplifier information. The following methods are available to allow this amplifier feature to be used by CML programs.

- const [Error](#) * [GetTraceStatus](#) ([AMP_TRACE_STATUS](#) &stat, [int16](#) &samp, [int16](#) &sampMax)
Get the current status of the amplifier's trace system.
- const [Error](#) * [GetTraceRefPeriod](#) ([int32](#) &per)
Get the 'reference period' used with the amplifiers trace mechanism.
- const [Error](#) * [GetTracePeriod](#) ([int16](#) &per)
Get the period of time between trace samples.
- const [Error](#) * [SetTracePeriod](#) ([int16](#) per)
Set the period of time between trace samples.
- const [Error](#) * [GetTraceTrigger](#) ([AMP_TRACE_TRIGGER](#) &type, [uint8](#) &chan, [int32](#) &level, [int16](#) &delay)
Get the current configuration of the amplifier's trace trigger.
- const [Error](#) * [SetTraceTrigger](#) ([AMP_TRACE_TRIGGER](#) type, [uint8](#) chan=0, [int32](#) level=0, [int16](#) delay=0)
Configure the amplifier's trace trigger.
- const [Error](#) * [GetTraceMaxChannel](#) ([uint8](#) &max)
Return the maximum number of trace channels supported by the amplifier.
- const [Error](#) * [GetTraceChannel](#) ([uint8](#) ndx, [AMP_TRACE_VAR](#) &value)
Get the amplifier variable current selected on one of the trace channels.
- const [Error](#) * [SetTraceChannel](#) ([uint8](#) ndx, [AMP_TRACE_VAR](#) value)
Select an amplifier trace variable to be sampled.
- const [Error](#) * [GetTraceData](#) ([int32](#) *data, [int32](#) &max)
Upload any trace data captured in the amplifier.
- const [Error](#) * [TraceStart](#) (void)
Start collecting trace data on the amplifier.
- const [Error](#) * [TraceStop](#) (void)
Stop collecting trace data on the amplifier.

Protected Member Functions

- const [Error](#) * [ClearEventLatch](#) ([EVENT_STATUS](#) stat)
Clear the latched version of the amplifier's event status register.
- virtual void [HandleStateChange](#) ([NodeState](#) from, [NodeState](#) to)
Handle an amplifier state change.
- const [Error](#) * [FormatPosInit](#) ([int32](#) pos, [uint8](#) *data)
Format a PVT segment to set the initial 32-bit position on a drive.
- const [Error](#) * [FormatPvtSeg](#) ([int32](#) pos, [int32](#) vel, [uint8](#) time, [uint8](#) *buff)
Format a PVT trajectory segment.
- const [Error](#) * [FormatPtSeg](#) ([int32](#) pos, [uint8](#) time, [uint8](#) *buff)
Format a PT trajectory segment.
- const [Error](#) * [SetPvtInitialPos](#) ([int32](#) pos, bool viaSDO=true)
Set the initial position for a PVT trajectory.
- const [Error](#) * [PvtBufferFlush](#) (bool viaSDO=true)
Flush the amplifier's PVT trajectory buffer.
- const [Error](#) * [PvtBufferPop](#) ([uint16](#) n=1, bool viaSDO=true)
Pop the N most recently sent segments off the amplifier's PVT trajectory buffer.

- const [Error](#) * [PvtClearErrors](#) (uint8 mask, bool viaSDO=true)
Clear the specified PVT buffer errors.
- const [Error](#) * [PvtWriteBuff](#) (uint8 *buff, bool viaSDO=false)
Write to the PVT buffer on the amp.
- const [Error](#) * [PvtWriteBuff](#) (uint8 buff[][8], int ct, bool viaSDO=false)
Write multiple PVT buffers to the drive.

Protected Attributes

- [EventMap](#) eventMap
This is an event map that is used to track amplifier events and state changes.

Friends

- class [Linkage](#)

Additional Inherited Members

5.4.1 Detailed Description

Copley Controls amplifier object.

This object represents a Copley Controls amplifier on the network.

The [Amp](#) object can be used directly for fairly easy control of an amplifier on the CANopen network. The object provides easy to use methods for setting and getting amplifier parameter blocks. It also handles many of the details of both point to point moves and the transfer of complex PVT profiles.

In addition, the standard [Amp](#) object provides several virtual functions which can be used in derived classes to signal the derived object on state changes or emergency conditions.

5.4.2 Constructor & Destructor Documentation

5.4.2.1 [Amp](#) () [inline]

Default constructor.

[Init\(\)](#) must be called before the [Amp](#) object may be used.

5.4.2.2 [Amp](#) ([Network](#) & net, int16 nodeID)

Construct and initialize an amplifier object using defaults for all amp settings.

Parameters

<i>net</i>	Reference to the network object for this amp.
<i>nodeID</i>	a valid node ID for the amp. For CANopen, the node ID should range from 1 to 127. For EtherCAT , node ID's >= 0 identify the node by it's EtherCAT alias. Negative ID's identify the node by network position (-1 is the first node, -2 is the second, etc).

5.4.2.3 Amp (Network & *net*, int16 *nodeID*, AmpSettings & *settings*)

Construct and initialize an amplifier object.

Parameters

<i>net</i>	Reference to the Network for this amp.
<i>nodeID</i>	a valid node ID for the amp. For CANopen, the node ID should range from 1 to 127. For EtherCAT , node ID's ≥ 0 identify the node by it's EtherCAT alias. Negative ID's identify the node by network position (-1 is the first node, -2 is the second, etc).
<i>settings</i>	Amplifier settings to be used.

5.4.3 Member Function Documentation

5.4.3.1 `uunit AccLoad2User (int32 acc) [virtual]`

Convert an acceleration from internal amplifier units to user units.

Internal to the amplifier, all accelerations are stored in units of 10 encoder counts / second². If user units are not enabled in [CML_Settings.h](#), then user units are the same as amplifier units, and this function has no effect.

If user units are enabled, then this function converts from amplifier units to user units (defined using [Amp::SetCountsPerUnit](#)).

For dual encoder systems the unit conversion used by this function is based on the load encoder resolution. To convert motor encoder accelerations, use [Amp::AccMtr2User](#). On single encoder systems either of these functions can be used.

Parameters

<i>acc</i>	The acceleration in units of 10 encoder counts / second ²
------------	--

Returns

The acceleration in user units

5.4.3.2 `uunit AccMtr2User (int32 acc) [virtual]`

Convert an acceleration from internal amplifier units to user units.

This function converts using motor encoder units on a dual encoder system. Load encoder accelerations can be converted using [Amp::AccLoad2User](#).

Parameters

<i>acc</i>	The acceleration in units of 10 encoder counts / second ²
------------	--

Returns

The acceleration in user units

5.4.3.3 `int32 AccUser2Load (uunit acc) [virtual]`

Convert an acceleration from user units to internal amplifier units.

Internal to the amplifier, all accelerations are stored in units of 10 encoder counts / second / second. If user units are not enabled in [CML_Settings.h](#), then user units are the same as amplifier units, and this function has no effect.

If user units are enabled, then this function converts from user units (defined using [Amp::SetCountsPerUnit](#)) to these internal amplifier units.

For dual encoder systems the unit conversion used by this function is based on the load encoder resolution. To convert motor encoder accelerations, use [Amp::AccUser2Mtr](#). On single encoder systems either of these functions can be used.

Parameters

<i>acc</i>	The acceleration in user units
------------	--------------------------------

Returns

The acceleration in 10 encoder counts / second ² units

5.4.3.4 `int32 AccUser2Mtr (uunit acc) [virtual]`

Convert an acceleration from user units to internal amplifier units.

This function converts using motor encoder units on a dual encoder system. Load encoder accelerations can be converted using [Amp::AccUser2Load](#).

Parameters

<i>acc</i>	The acceleration in user units
------------	--------------------------------

Returns

The acceleration in 10 encoder counts / second ² units

5.4.3.5 `const Error * CheckStateForMove (void)`

Check the amplifier's state to make sure a move can be started.

This function is used internally by the functions that start moves & homing. It looks at the current state of the amplifier and returns an appropriate error code if something is wrong that would cause problems during a move/home.

Returns

A pointer to an error object, or NULL for no error

5.4.3.6 `const Error * ClearEventLatch (EVENT_STATUS stat) [protected]`

Clear the latched version of the amplifier's event status register.

This function is protected and generally only intended for internal use.

Parameters

<i>stat</i>	Identifies which bits to clear. Any bit set in this parameter will be cleared in the latched event status register.
-------------	---

Returns

A pointer to an error object, or NULL on success

5.4.3.7 `const Error * ClearFaults (void)`

Clear amplifier faults.

This function can be used to clear any latching faults on the amplifier (see [Amp::SetFaultMask](#) for details on latching fault conditions). It also clears tracking error conditions.

Returns

A pointer to an error object, or NULL on success

5.4.3.8 const Error * ClearNodeGuardEvent (void)

This function attempts to clear a node guarding event condition.

Node guarding events occur when the amplifier fails to respond to its heartbeat protocol for some reason. This could be caused by a network wiring problem, slow processing on the master controller (causing the amplifier guard message to be delayed or lost), or an amplifier error such as a reset or power down.

In any case, once a node guarding error is identified, the error condition must be cleared before any new moves may be performed.

This function attempts to clear the node guarding event condition, however if it determines that the amplifier has been reset then it fails and returns the error object [AmpError::Reset](#). In this case, the amplifier object must be reinitialized before it can be used. The amp may be reinitialized by calling [Amp::Init](#) or [Amp::ReInit](#).

If node guarding error become a problem, it may mean that the guard time is set too low. This can be adjusted when the amplifier object is initialized by the values in the [AmpSettings](#) object.

Returns

A pointer to an error object, or NULL on success.

5.4.3.9 const Error * Disable (bool wait = true)

Disable the amplifier.

Note that if the brake delays are in use, then the amplifier may still be enabled when this function returns success. The outputs will actually be disabled after the amplifier finishes the braking procedure.

Parameters

<i>wait</i>	Wait for confirmation from the amplifier if true (default).
-------------	---

Returns

A pointer to an error object, or NULL on success.

5.4.3.10 const Error * Dnld16 (int16 index, int16 sub, uint16 data)

Download data to an object in this Amps object dictionary.

The object number is adjusted based on the axis number if necessary.

Parameters

<i>index</i>	The index of the object to be downloaded.
<i>sub</i>	The sub-index of the object to be downloaded.

<i>data</i>	The value to be downloaded.
-------------	-----------------------------

Returns

A pointer to an error object, or NULL on success

5.4.3.11 const Error * Dnld16 (int16 index, int16 sub, int16 data)

Download data to an object in this Amps object dictionary.

The object number is adjusted based on the axis number if necessary.

Parameters

<i>index</i>	The index of the object to be downloaded.
<i>sub</i>	The sub-index of the object to be downloaded.
<i>data</i>	The value to be downloaded.

Returns

A pointer to an error object, or NULL on success

5.4.3.12 const Error * Dnld32 (int16 index, int16 sub, uint32 data)

Download data to an object in this Amps object dictionary.

The object number is adjusted based on the axis number if necessary.

Parameters

<i>index</i>	The index of the object to be downloaded.
<i>sub</i>	The sub-index of the object to be downloaded.
<i>data</i>	The value to be downloaded.

Returns

A pointer to an error object, or NULL on success

5.4.3.13 const Error * Dnld32 (int16 index, int16 sub, int32 data)

Download data to an object in this Amps object dictionary.

The object number is adjusted based on the axis number if necessary.

Parameters

<i>index</i>	The index of the object to be downloaded.
<i>sub</i>	The sub-index of the object to be downloaded.
<i>data</i>	The value to be downloaded.

Returns

A pointer to an error object, or NULL on success

5.4.3.14 `const Error * Dnld8 (int16 index, int16 sub, uint8 data)`

Download data to an object in this Aamps object dictionary.

The object number is adjusted based on the axis number if necessary.

Parameters

<i>index</i>	The index of the object to be downloaded.
<i>sub</i>	The sub-index of the object to be downloaded.
<i>data</i>	The value to be downloaded.

Returns

A pointer to an error object, or NULL on success

5.4.3.15 `const Error * Dnld8 (int16 index, int16 sub, int8 data)`

Download data to an object in this Aamps object dictionary.

The object number is adjusted based on the axis number if necessary.

Parameters

<i>index</i>	The index of the object to be downloaded.
<i>sub</i>	The sub-index of the object to be downloaded.
<i>data</i>	The value to be downloaded.

Returns

A pointer to an error object, or NULL on success

5.4.3.16 `const Error * DnldString (int16 index, int16 sub, char * data)`

Download data to an object in this Aamps object dictionary.

The object number is adjusted based on the axis number if necessary.

Parameters

<i>index</i>	The index of the object to be downloaded.
<i>sub</i>	The sub-index of the object to be downloaded.
<i>data</i>	The value to be downloaded.

Returns

A pointer to an error object, or NULL on success

5.4.3.17 `const Error * DoMove (ProfileConfigTrap & cfg, bool relative = false)`

Perform a point to point move.

The move will use the trapezoidal profile mode, and all parameters will be programmed before the move is started.

This function can also be used to update a move that is already in progress.

Parameters

<i>cfg</i>	A structure holding all the move configuration parameters.
<i>relative</i>	This will be a relative move if true, absolute if false (default)

Returns

A pointer to an error object, or NULL on success.

5.4.3.18 `const Error * DoMove (ProfileConfigScurve & cfg, bool relative = false)`

Perform a point to point move.

The move will use the S-curve profile mode, and all parameters will be programmed before the move is started.

Parameters

<i>cfg</i>	A structure holding all the move configuration parameters.
<i>relative</i>	This will be a relative move if true, absolute if false (default)

Returns

A pointer to an error object, or NULL on success.

5.4.3.19 `const Error * DoMove (ProfileConfigVel & cfg)`

Perform a velocity profile move.

All parameters will be programmed before the move is started.

This function can also be used to update a move that is already in progress.

Parameters

<i>cfg</i>	A structure holding all the move configuration parameters.
------------	--

Returns

A pointer to an error object, or NULL on success.

5.4.3.20 `const Error * DoMove (uunit pos, bool relative = false)`

Perform a point to point move.

It's assumed that the drive is already configured with the properly trajectory parameters (velocity, acceleration, deceleration, profile type, etc).

This function sets the trajectories target position to the passed value, and manipulates the control word to start the move. It can be used for either absolute moves or relative moves

Parameters

<i>pos</i>	Position to move to (absolute) or distance to move (relative).
<i>relative</i>	True if this is a relative move, false for absolute.

Returns

A pointer to an error object, or NULL on success.

5.4.3.21 `const Error * Download (int16 index, int16 sub, int32 size, byte * data)`

Download data to an object in this Amps object dictionary.

The object number is adjusted based on the axis number if necessary.

Parameters

<i>index</i>	The index of the object to be downloaded.
<i>sub</i>	The sub-index of the object to be downloaded.
<i>size</i>	The number of bytes of data to be downloaded
<i>data</i>	A character array holding the data to be downloaded.

Returns

A pointer to an error object, or NULL on success

5.4.3.22 `const Error * Enable (bool wait = true)`

Enable the amplifier.

Parameters

<i>wait</i>	If true, the function won't return until a status message from the amp is received indicating that it successfully enabled.
-------------	---

Returns

A pointer to an error object, or NULL on success.

5.4.3.23 `const Error * FormatPosnit (int32 pos, uint8 * data) [protected]`

Format a PVT segment to set the initial 32-bit position on a drive.

Parameters

<i>pos</i>	The 32-bit initial position
<i>data</i>	Buffer of at least 8 bytes where formatted data will be stored.

Returns

An error object

5.4.3.24 `const Error * FormatPtSeg (int32 pos, uint8 time, uint8 * buff)` [protected]

Format a PT trajectory segment.

The position and time information passed to the function are organized into the proper format and stored in the passed buffer. The buffer is assumed to be at least 8 bytes long.

Parameters

<i>pos</i>	Position at start of segment (encoder counts)
<i>time</i>	Time till next segment (milliseconds)
<i>buff</i>	Points to the buffer where the message will be stored.

Returns

An error object

5.4.3.25 `const Error * FormatPvtSeg (int32 pos, int32 vel, uint8 time, uint8 * buff)` [protected]

Format a PVT trajectory segment.

The position, velocity and time information passed to the function are organized into the proper format and stored in the passed buffer. The buffer is assumed to be at least 8 bytes long.

Parameters

<i>pos</i>	Position at start of segment (encoder counts)
<i>vel</i>	Velocity at start of segment (0.1 counts/sec)
<i>time</i>	Time till next segment (milliseconds)
<i>buff</i>	Points to the buffer where the message will be stored.

Returns

An error object

5.4.3.26 `const Error * GetAlgoPhaseInit (AlgoPhaseInit & cfg)`

Upload the current configuration parameters for the algorithmic phase init.

Parameters

<i>cfg</i>	A structure where the configuration parameters will be returned.
------------	--

Returns

A pointer to an error object, or NULL on success

5.4.3.27 `const Error * GetAmpConfig (AmpConfig & cfg)`

Read the complete amplifier configuration from the amplifier and return it in the passed structure.

This structure holds every amplifier parameter that can be stored to the amplifier's internal flash memory. The contents of the structure represent the complete amplifier configuration.

Parameters

<i>cfg</i>	The structure which will hold the uploaded configuration.
------------	---

Returns

A pointer to an error object, or NULL on success

5.4.3.28 `const Error * GetAmpInfo (AmpInfo & info)`

Read the Amplifier information parameters from the drive.

These parameters describe the amplifiers capabilities. They are read only.

Parameters

<i>info</i>	A structure that will be filled with the amplifier info
-------------	---

Returns

A pointer to an error object, or NULL on success

5.4.3.29 `const Error * GetAmpMode (AMP_MODE & mode)`

Get the currently active amplifier mode of operation.

Parameters

<i>mode</i>	The active mode of operation is returned here
-------------	---

Returns

A pointer to an error object, or NULL on success.

5.4.3.30 `const Error * GetAmpName (char * name)`

Get the amplifier name stored in the amplifiers flash.

Parameters

<i>name</i>	The name of the drive is returned here. This buffer should be at least 50 bytes long to avoid overflow.
-------------	---

Returns

A pointer to an error object, or NULL on success

5.4.3.31 `const Error * GetAmpTemp (int16 & value)`

Get the current amplifier temperature (degrees C).

Parameters

<i>value</i>	The value will be returned in this variable
--------------	---

Returns

A pointer to an error object, or NULL on success

5.4.3.32 `const Error * GetAnalogCommandFilter (Filter & f)`

Get the coefficients used in the velocity loop command filter.

Parameters

<i>f</i>	A structure where the filter coefficients will be returned
----------	--

Returns

A pointer to an error object, or NULL on success

5.4.3.33 `const Error * GetAnalogEncoder (int16 & sin, int16 & cos)`

Get the raw voltage on the two analog encoder inputs (0.1 millivolt units).

If the amplifier has analog encoder inputs, then they will be read and returned.

Parameters

<i>sin</i>	The sine input of the analog encoder will be returned here.
<i>cos</i>	The cosine input of the analog encoder will be returned here.

Returns

A pointer to an error object, or NULL on success

5.4.3.34 `const Error * GetAnalogRefConfig (AnalogRefConfig & cfg)`

Upload the amplifier's analog reference input configuration.

Parameters

<i>cfg</i>	A structure where the configuration parameters will be returned.
------------	--

Returns

A pointer to an error object, or NULL on success

5.4.3.35 `const Error * GetCammingConfig (CammingConfig & cfg)`

Upload the current configuration parameters for the camming.

Parameters

<i>cfg</i>	A structure where the configuration parameters will be returned.
------------	--

Returns

A pointer to an error object, or NULL on success

5.4.3.36 `const Error * GetCanNetworkConfig (CanNetworkConfig & cfg)`

Get the current CANopen network configuration programmed into the amplifier.

Parameters

<i>cfg</i>	A structure where the configuration parameters will be returned.
------------	--

Returns

A pointer to an error object, or NULL on success

5.4.3.37 `const Error * GetControlWord (uint16 & value)`

Returns the present value of the CANopen device profile control word.

Parameters

<i>value</i>	Returns the control word value
--------------	--------------------------------

Returns

A pointer to an error object, or NULL on success

5.4.3.38 `const Error * GetCountsPerUnit (uunit & cts) [virtual]`

Get the number of encoder counts / user distance unit.

This function is only available when user units are selected in [CML_Settings.h](#).

This value defaults to 1.0 (i.e. user distance units are in encoder counts). It can be adjusted if some other distance unit is desired.

This value controls velocity, acceleration, and jerk units also. These units are always based on a time interval of seconds.

Parameters

<i>cts</i>	The count value will be returned here
------------	---------------------------------------

Returns

A pointer to an error object, or NULL on success

5.4.3.39 `const Error * GetCountsPerUnit (uunit & load, uunit & mtr) [virtual]`

Get the number of encoder counts / user distance unit for both encoders in a dual encoder system.

This function is only available when user units are selected in [CML_Settings.h](#).

These values default to 1.0 (i.e. user distance units are in encoder counts). It can be adjusted if some other distance unit is desired.

These values control velocity, acceleration, and jerk units also. These units are always based on a time interval of seconds.

Parameters

<i>load</i>	The load encoder scaling factor will be returned here
<i>mtr</i>	The motor encoder scaling factor will be returned here

Returns

A pointer to an error object, or NULL on success

5.4.3.40 `const Error * GetCrntLoopConfig (CrntLoopConfig & cfg)`

Get the configuration values of the amplifiers current loop.

Parameters

<i>cfg</i>	A structure that will be filled with the config info.
------------	---

Returns

A pointer to an error object, or NULL on success

5.4.3.41 `const Error * GetCurrentActual (int16 & value)`

Get the actual motor current.

This current is based on the amplifiers current sensors, and indicates the portion of current that is being used to generate torque in the motor.

The current is returned in units of 0.01 amps.

Parameters

<i>value</i>	A variable that will store the returned value.
--------------	--

Returns

A pointer to an error object, or NULL on success

5.4.3.42 `const Error * GetCurrentCommand (int16 & value)`

Get the commanded motor current.

This current is the input to the current limiter. This value is also the output of the velocity loop when the motor is in either position or velocity control mode. When in current control mode, the commanded current is derived from the control source (analog input, PWM input, function generator, etc).

The current is returned in units of 0.01 amps.

Parameters

<i>value</i>	A variable that will store the returned value.
--------------	--

Returns

A pointer to an error object, or NULL on success

5.4.3.43 `const Error * GetCurrentLimited (int16 & value)`

Get the limited motor current.

The commanded current (GetCurrentCommand) is passed to a current limiter. The output of the current limiter is the limited current which is passed as an input to the current loop.

The current is returned in units of 0.01 amps.

Parameters

<i>value</i>	A variable that will store the returned value.
--------------	--

Returns

A pointer to an error object, or NULL on success

5.4.3.44 `const Error * GetCurrentProgrammed (int16 & crnt)`

Get the programmed current value.

This parameter is the current that the amplifier will attempt to maintain when set to the mode AMPMODE_PROG_CRNT.

Parameters

<i>crnt</i>	The current will be returned here (0.01 Amp units).
-------------	---

Returns

A pointer to an error object, or NULL on success

5.4.3.45 `const Error * GetDAConverterConfig (DACConfig & cfg)`

Get the configuration for the D/A converter.

Parameters

<i>cfg</i>	A structure where the configuration will be returned
------------	--

Returns

A pointer to an error object, or NULL on success

5.4.3.46 `const Error * GetErrorStatus (bool noComm = false)`

Return an error object identifying the amplifiers status.

This function causes the amplifier object to examine it's event mask and return an error object corresponding to the most serious error present.

Parameters

<i>noComm</i>	If true, then no CAN message communications will be performed by this function. This is useful if the function is being called from a CAN message handler which can't perform SDO communications. If false (default), then the amplifier may be queried for more detailed error information.
---------------	--

Returns

A pointer to an error object, or NULL if no errors are present

5.4.3.47 `const Error * GetEventLatch (EVENT_STATUS & stat)`

Get the amplifier's latched event status register.

This register is a copy of the normal event status register in which bits are latched, i.e. they are set bit not cleared. Bits in this register are only cleared in response to a [Amp::ClearEventLatch](#) function call (which is protected by the [Amp](#) object). This register is primarily used internally by the [Amp](#) object to detect reset conditions on the amplifier.

Parameters

<i>stat</i>	The register status is returned here.
-------------	---------------------------------------

Returns

A pointer to an error object, or NULL on success

5.4.3.48 `const Error * GetEventMask (AMP_EVENT & e)`

Get the current state of the amplifier's event mask.

The event mask is a bit-mapped variable identifies many interesting elements of the amplifiers state. The contents of this variable are built up from several different amplifier status words which are constantly updated over the CANopen network.

When the event mask is read using this function, no new messages are passed over the network. The current value of the event mask is simply returned. Any time the amplifier's state changes, it sends a message over the CANopen network which is used to update this mask.

It is also possible to wait on a particular value for this mask. See [Amp::WaitEvent](#) for details.

Parameters

<i>e</i>	The amplifier's event mask is returned here
----------	---

Returns

A pointer to an error object, or NULL on success.

5.4.3.49 `const Error * GetEventStatus (EVENT_STATUS & stat)`

Get the amplifier's 'event status' register.

This is the main register used internal to the amplifier to describe it's current state.

Parameters

<i>stat</i>	The register status is returned here.
-------------	---------------------------------------

Returns

A pointer to an error object, or NULL on success

5.4.3.50 `const Error * GetEventSticky (EVENT_STATUS & stat)`

Get the amplifier's 'sticky' event status register.

This register is a copy of the amplifiers event status register in which bits are set normally, but only cleared when the register is read (i.e. the bits are 'sticky'). It's useful for checking for transitory events which might be missed by reading the standard event status register.

Parameters

<i>stat</i>	The register status is returned here.
-------------	---------------------------------------

Returns

A pointer to an error object, or NULL on success

5.4.3.51 `const Error * GetFaultMask (AMP_FAULT & value)`

Get the current value of the amplifier's fault mask.

This mask identifies which error conditions will be treated as latching faults by the amplifier.

Parameters

<i>value</i>	The fault mask will be returned here
--------------	--------------------------------------

Returns

A pointer to an error object, or NULL on success

5.4.3.52 `const Error * GetFaults (AMP_FAULT & value)`

Get any active amplifier faults.

Parameters

<i>value</i>	A bit mask identifying the active faults will be returned here.
--------------	---

Returns

A pointer to an error object, or NULL on success

5.4.3.53 `const Error * GetFuncGenConfig (FuncGenConfig & cfg)`

Upload the current configuration of the amplifier's internal function generator.

Parameters

<i>cfg</i>	A structure where the configuration will be returned.
------------	---

Returns

A pointer to an error object, or NULL on success

5.4.3.54 `const Error * GetGainScheduling (GainScheduling & cfg)`

Upload the current configuration parameters for the GainS scheduling.

Parameters

<i>cfg</i>	A structure where the configuration parameters will be returned.
------------	--

Returns

A pointer to an error object, or NULL on success

5.4.3.55 `const Error * GetHallState (int16 & value)`

Get the current digital hall sensor state.

The hall state is the value of the hall sensors after any adjustments have been made to them based on the hallWiring parameter of the [MtrInfo](#) structure.

Parameters

<i>value</i>	variable that will store the returned value
--------------	---

Returns

A pointer to an error object, or NULL on success

5.4.3.56 `const Error * GetHaltMode (HALT_MODE & mode)`

Get the halt mode.

This mode defines what happens when a halt command is issued to the amplifier.

Parameters

<i>mode</i>	The mode will be returned here.
-------------	---------------------------------

Returns

A pointer to an error object, or NULL on success

5.4.3.57 `const Error * GetHighVoltage (int16 & value)`

Get the high voltage bus voltage in units of 0.1 volts.

Parameters

<i>value</i>	The value will be returned in this variable
--------------	---

Returns

A pointer to an error object, or NULL on success

5.4.3.58 `const Error * GetHomeAccel (uunit & value)`

Get the home acceleration.

This parameter is specified in "user units". See [Amp::SetCountsPerUnit](#) for details.

Parameters

<i>value</i>	variable that will store the returned value
--------------	---

Returns

A pointer to an error object, or NULL on success

5.4.3.59 `const Error * GetHomeAdjustment (uunit & value)`

Get the last home adjustment amount.

The value returned is distance that the home position was adjusted by on the last successful home operation.

This parameter is specified in "user units". See [Amp::SetCountsPerUnit](#) for details.

Parameters

<i>value</i>	variable that will store the returned value
--------------	---

Returns

A pointer to an error object, or NULL on success

5.4.3.60 `const Error * GetHomeCapture (int32 & value)`

Get the most recently captured home sensor position.

Parameters

<i>value</i>	The captured position is returned here in units of encoder counts.
--------------	--

Returns

A pointer to an error object, or NULL on success

5.4.3.61 `const Error * GetHomeConfig (HomeConfig & cfg)`

Load a structure with all parameters related to homing the amplifier.

Parameters

<i>cfg</i>	A structure where the configuration parameters will be returned.
------------	--

Returns

A pointer to an error object, or NULL on success

5.4.3.62 `const Error * GetHomeCurrent (int16 & value)`

Get the home current.

The homing current is returned in 0.01 [Amp](#) units (i.e. a value of 123 would be 1.23 Amps).

Parameters

<i>value</i>	variable that will store the returned value
--------------	---

Returns

A pointer to an error object, or NULL on success

5.4.3.63 `const Error * GetHomeDelay (int16 & value)`

Get the home current.

The homing delay is returned in units of milliseconds.

Parameters

<i>value</i>	variable that will store the returned value
--------------	---

Returns

A pointer to an error object, or NULL on success

5.4.3.64 `const Error * GetHomeMethod (COPLEY_HOME_METHOD & method, uint16 * extended = 0)`

Get the selected homing method.

Parameters

<i>method</i>	The home method will be returned here.
<i>extended</i>	If this pointer is non-null, then the extended homing method value will be returned here. If this pointer is null, then it will be ignored.

Returns

A pointer to an error object, or NULL on success

5.4.3.65 `const Error * GetHomeOffset (uint & value)`

Get the home offset value.

This parameter is specified in "user units". See [Amp::SetCountsPerUnit](#) for details.

Parameters

<i>value</i>	variable that will store the returned value
--------------	---

Returns

A pointer to an error object, or NULL on success

5.4.3.66 **const Error * GetHomeVelFast (uunit & value)**

Get the home velocity used to move to a home switch.

This velocity is used for any home moves that may be made at a high velocity without effecting the quality of the home sensor detection.

This parameter is specified in "user units". See [Amp::SetCountsPerUnit](#) for details.

Parameters

<i>value</i>	variable that will store the returned value
--------------	---

Returns

A pointer to an error object, or NULL on success

5.4.3.67 **const Error * GetHomeVelSlow (uunit & value)**

Get the home velocity used to find a switch edge.

This parameter is specified in "user units". See [Amp::SetCountsPerUnit](#) for details.

Parameters

<i>value</i>	variable that will store the returned value
--------------	---

Returns

A pointer to an error object, or NULL on success

5.4.3.68 **const Error * GetloopCommandFilter (Filter & f)**

Get the coefficients used in the current loop input filter.

Parameters

<i>f</i>	A structure where the filter coefficients will be returned
----------	--

Returns

A pointer to an error object, or NULL on success

5.4.3.69 **const Error * GetloopCommandFilter2 (Filter & f)**

Get the coefficients used in the second current loop input filter.

Parameters

<i>f</i>	A structure where the filter coefficients will be returned
----------	--

Returns

A pointer to an error object, or NULL on success

5.4.3.70 `const Error * GetIndexCapture (int32 & value)`

Get the most recently captured encoder index position.

Parameters

<i>value</i>	The captured position is returned here in units of encoder counts.
--------------	--

Returns

A pointer to an error object, or NULL on success

5.4.3.71 `const Error * GetInputConfig (int8 pin, INPUT_PIN_CONFIG & cfg)`

Get the input pin configuration for the specified input pin.

Each of the amplifier input pins can be configured to perform some function. This function configures the specified input to perform the specified function.

Parameters

<i>pin</i>	The input pin to check. Input pins are numbered starting from 0. Check the amplifier datasheet for the number of input pins available.
<i>cfg</i>	The input pin function will be returned in this variable.

Returns

A pointer to an error object, or NULL on success

5.4.3.72 `const Error * GetInputConfig (int8 pin, INPUT_PIN_CONFIG & cfg, uint16 & axis)`

Get the input pin configuration for the specified input pin.

Each of the amplifier input pins can be configured to perform some function. This function configures the specified input to perform the specified function.

Parameters

<i>pin</i>	The input pin to check. Input pins are numbered starting from 0. Check the amplifier datasheet for the number of input pins available.
------------	--

<i>cfg</i>	The input pin function will be returned in this variable.
<i>axis</i>	The axis number that this input pin is configured for

Returns

A pointer to an error object, or NULL on success

5.4.3.73 `const Error * GetInputDebounce (int8 pin, int16 & value)`

Get the input pin debounce time for the specified input pin.

Parameters

<i>pin</i>	The input pin to configure. Input pins are numbered starting from 0. Check the amplifier datasheet for the number of input pins available.
<i>value</i>	The pins debounce time (milliseconds) is returned here.

Returns

A pointer to an error object, or NULL on success

5.4.3.74 `const Error * GetInputs (uint16 & value, bool viaSDO = false)`

Get the present value of the general purpose input pins.

The input pin values are returned one per bit. The value of input pin 1 will be returned in bit 0 (1 if high, 0 if low), pin 2 will be in bit 1, etc.

Parameters

<i>value</i>	variable that will store the returned value
<i>viaSDO</i>	If true, an SDO will be used to read the input pins. If false (default), the most recent input value received from the amplifier via PDO will be returned.

Returns

A pointer to an error object, or NULL on success

5.4.3.75 `const Error * GetInputs32 (uint32 & value)`

32-bit version to Get the present value of the general purpose input pins.

Note that only the lower 16 input pins are [PDO](#) mapped, so this function will always use an [SDO](#) access to read the full set of inputs. If the input of interest is one of the lower 16 pins, then the method [Amp::GetInputs\(\)](#) is generally a much faster way to read the pin's state.

The input pin values are returned one per bit. The value of input pin 1 will be returned in bit 0 (1 if high, 0 if low), pin 2 will be in bit 1, etc.

Parameters

<i>value</i>	variable that will store the returned value
--------------	---

Returns

A pointer to an error object, or NULL on success

5.4.3.76 `const Error * GetInputShapingFilter (InputShaper & f)`

Get the coefficients used in the input shaping filter.

Parameters

<i>f</i>	A structure where the filter coefficients will be returned
----------	--

Returns

A pointer to an error object, or NULL on success

5.4.3.77 `const Error * GetIoConfig (AmpIoCfg & cfg)`

Read the amplifier's programmable I/O pin configuration and return it in the passed config structure.

Parameters

<i>cfg</i>	A structure that holds the configuration settings.
------------	--

Returns

A pointer to an error object, or NULL on success

5.4.3.78 `const Error * GetIOOptions (int32 & value)`

Get the IO Options.

See the [Amp::SetIOOptions](#) method for description.

Parameters

<i>value</i>	variable that will store the returned value
--------------	---

Returns

A pointer to an error object, or NULL on success

5.4.3.79 `const Error * GetIoPullup (uint16 & value)`

Get the current state of the input pin pull up/down resistors.

Pull up/down resistors control how an undriven input pin will be interpreted by the amplifier. Depending on the model of amplifier being controlled, there may be zero or more groups of pull up/down resistors attached to some the input pins.

Each bit of this register is used to control one group of pull up/down resistors. Bit 0 controls group 0, etc.

Please refer to the amplifier data sheet for details on the number of groups of pull up/down resistors, and which input pins are included in each group.

Parameters

<i>value</i>	variable that will store the returned value
--------------	---

Returns

A pointer to an error object, or NULL on success

5.4.3.80 `const Error * GetloPullup32 (int32 & value)`

32 Bit version of GetloPullup.

This is useful on drives that support more than 16 pull up/down resistors. Please see [Amp::GetloPullup\(\)](#) for more details.

Parameters

<i>value</i>	variable that will store the returned value.
--------------	--

Returns

A pointer to an error object, or NULL on success

5.4.3.81 `Linkage * GetLinkage (void)`

Return a pointer to the linkage that this amplifier is attached to.

WARNING - this function is dangerous as the pointer is not locked. Use [Amp::GetLinkRef](#) instead!

Returns

The linkage pointer, or NULL if the [Amp](#) is not attached to any linkage object.

5.4.3.82 `uint32 GetLinkRef (void)`

Return a reference to the linkage that this amplifier is attached to.

Returns

The linkage reference, or 0 if the [Amp](#) is not attached to any linkage object.

5.4.3.83 `const Error * GetMicrostepRate (int16 & rate)`

Get the amplifier microstepping rate.

This parameter is only used in the diagnostic microstepping mode (AMPMODE_DIAG_USTEP).

Parameters

<i>rate</i>	The microstepping rate will be returned here (degrees / second).
-------------	--

Returns

A pointer to an error object, or NULL on success

5.4.3.84 `const Error * GetMotorCurrent (int16 & u, int16 & v)`

Get the actual current values read directly from the amplifier's current sensors.

Note that if the motor wiring is being swapped in software, the U and V reading will be swapped.

Parameters

<i>u</i>	The U winding current will be returned here.
<i>v</i>	The V winding current will be returned here.

Returns

A pointer to an error object, or NULL on success

5.4.3.85 `const Error * GetMtrInfo (MtrInfo & info)`

Read the motor information structure from the amplifier.

Parameters

<i>info</i>	A structure that will be filled with the motor info
-------------	---

Returns

A pointer to an error object, or NULL on success

5.4.3.86 `const Error * GetNetworkOptions (NetworkOptions & cfg)`

Set the [Network](#) Options configuration.

Parameters

<i>cfg</i>	Reference to the NetworkOptions structure where the configuration data will be returned.
------------	--

Returns

A pointer to an error object, or NULL on success

5.4.3.87 `uint32 GetNetworkRef (void) [virtual]`

Return a reference ID to the network that this node is attached to.

Returns

The reference ID or 0 if the node isn't attached to any network.

Reimplemented from [Node](#).

5.4.3.88 `const Error * GetOutputConfig (int8 pin, OUTPUT_PIN_CONFIG & cfg)`

Get the output configuration for the specified pin.

Parameters

<i>pin</i>	The output pin to check.
<i>cfg</i>	The pin configuration value will be returned here.

Returns

A pointer to an error object, or NULL on success

5.4.3.89 `const Error * GetOutputConfig (int8 pin, OUTPUT_PIN_CONFIG & cfg, uint16 & axis)`

Get the output configuration for the specified pin.

Parameters

<i>pin</i>	The output pin to check.
<i>cfg</i>	The pin configuration value will be returned here.
<i>axis</i>	On multi-axis drives the axis number that this output pin is configured for will be returned here.

Returns

A pointer to an error object, or NULL on success

5.4.3.90 `const Error * GetOutputConfig (int8 pin, OUTPUT_PIN_CONFIG & cfg, uint32 & mask)`

Get the output pin configuration for the specified pin.

Parameters

<i>pin</i>	The output pin to check.
<i>cfg</i>	The pin configuration value will be returned here.
<i>mask</i>	The pin's status bit selection mask will be returned here.

Returns

A pointer to an error object, or NULL on success

5.4.3.91 `const Error * GetOutputConfig (int8 pin, OUTPUT_PIN_CONFIG & cfg, uint32 & mask, uint16 & axis)`

Get the output pin configuration for the specified pin.

Parameters

<i>pin</i>	The output pin to check.
<i>cfg</i>	The pin configuration value will be returned here.
<i>mask</i>	The pin's status bit selection mask will be returned here.
<i>axis</i>	On multi-axis drives the axis number that this output pin is configured for will be returned here

Returns

A pointer to an error object, or NULL on success

5.4.3.92 `const Error * GetOutputConfig (int8 pin, OUTPUT_PIN_CONFIG & cfg, uint32 & param1, uint32 & param2)`

Get the output pin configuration for the specified pin.

This function supports output pin configurations that require two 32-bit parameters.

Parameters

<i>pin</i>	The output pin to check.
<i>cfg</i>	The pin configuration value will be returned here.
<i>param1</i>	The pin's first 32-bit parameter will be returned here
<i>param2</i>	The pin's second 32-bit parameter will be returned here

Returns

A pointer to an error object, or NULL on success

5.4.3.93 `const Error * GetOutputConfig (int8 pin, OUTPUT_PIN_CONFIG & cfg, uint32 & param1, uint32 & param2, uint16 & axis)`

Get the output pin configuration for the specified pin.

This function supports output pin configurations that require two 32-bit parameters.

Parameters

<i>pin</i>	The output pin to check.
<i>cfg</i>	The pin configuration value will be returned here.
<i>param1</i>	The pin's first 32-bit parameter will be returned here
<i>param2</i>	The pin's second 32-bit parameter will be returned here
<i>axis</i>	On multi-axis drives the axis number that this pin is configured for will be returned here

Returns

A pointer to an error object, or NULL on success

5.4.3.94 `const Error * GetOutputs (uint16 & value)`

Get the present value of the output pin control register.

This register shows the current state of all digital output pins. For each pin, the corresponding bit in the register will be 1 if the pin is active, and 0 if the pin is inactive. Bit 0 follows output pin 0, bit 1 follows pin 1, etc.

Parameters

<i>value</i>	variable that will store the returned value
--------------	---

Returns

A pointer to an error object, or NULL on success

5.4.3.95 `const Error * GetPhaseAngle (int16 & value)`

Get the motor phase angle.

The phase angle describes the motor's electrical position with respect to its windings. It's an internal parameter used by the amplifier to commutate a brushless motor.

The angle is returned in degrees.

Parameters

<i>value</i>	variable that will store the returned value
--------------	---

Returns

A pointer to an error object, or NULL on success

5.4.3.96 `const Error * GetPhaseMode (AMP_PHASE_MODE & mode)`

Get the current phasing mode configuration from the amplifier.

Parameters

<i>mode</i>	The mode information will be returned here.
-------------	---

Returns

A pointer to an error object, or NULL on success

5.4.3.97 `const Error * GetPosCaptureCfg (POS_CAPTURE_CFG & cfg)`

Read the current configuration of the position capture mechanism.

Parameters

<i>cfg</i>	The position capture configuration value is returned here.
------------	--

Returns

A pointer to an error object, or NULL on success

5.4.3.98 `const Error * GetPosCaptureStat (POS_CAPTURE_STAT & stat)`

Read the current status of the position capture mechanism.

Parameters

<i>stat</i>	The position capture status value is returned here.
-------------	---

Returns

A pointer to an error object, or NULL on success

5.4.3.99 `const Error * GetPositionActual (uunit & value)`

Get the actual position used by the servo loop.

For dual encoder systems, this will be the load encoder position. To get the motor encoder position on such a system, use [Amp::GetPositionMotor](#).

This parameter is specified in "user units". See [Amp::SetCountsPerUnit](#) for details.

Parameters

<i>value</i>	variable that will store the returned value
--------------	---

Returns

A pointer to an error object, or NULL on success

5.4.3.100 `const Error * GetPositionCommand (uunit & value)`

Get the instantaneous commanded position.

This position is the command input to the servo loop. The commanded position is calculated by the trajectory generator and updated every servo cycle.

This parameter is specified in "user units". See [Amp::SetCountsPerUnit](#) for details.

Parameters

<i>value</i>	variable that will store the returned value
--------------	---

Returns

A pointer to an error object, or NULL on success

5.4.3.101 `const Error * GetPositionError (uunit & value)`

Get the position error.

This is the difference between the instantaneous commanded position and the actual position.

This parameter is specified in "user units". See [Amp::SetCountsPerUnit](#) for details.

Parameters

<i>value</i>	variable that will store the returned value
--------------	---

Returns

A pointer to an error object, or NULL on success

5.4.3.102 `const Error * GetPositionErrorWindow (uunit & value)`

Get the position error window.

This parameter is specified in "user units". See [Amp::SetCountsPerUnit](#) for details.

Parameters

<i>value</i>	The position error window value will be returned here.
--------------	--

Returns

A pointer to an error object, or NULL on success

5.4.3.103 const Error * GetPositionLoad (uunit & value)

Get the load encoder position.

For single encoder systems, this value is NOT USED.

For dual encoder systems, this function returns the load encoder position and is identical to the value returned by [Amp::GetPositionActual](#). This is also the passive load position when the load encoder is configured to be in passive mode.

Parameters

<i>value</i>	variable that will store the returned value
--------------	---

Returns

A pointer to an error object, or NULL on success

5.4.3.104 const Error * GetPositionMotor (uunit & value)

Get the actual motor position.

For single encoder systems, this value is identical to the value returned by [Amp::GetPositionActual](#).

For dual encoder systems, this function returns the actual motor position and [Amp::GetPositionActual](#) may be used to get the load encoder position.

Parameters

<i>value</i>	variable that will store the returned value
--------------	---

Returns

A pointer to an error object, or NULL on success

5.4.3.105 const Error * GetPositionWarnWindow (uunit & value)

Get the position warning window.

This parameter is specified in "user units". See [Amp::SetCountsPerUnit](#) for details.

Parameters

<i>value</i>	variable that will store the returned value
--------------	---

Returns

A pointer to an error object, or NULL on success

5.4.3.106 const Error * GetPosLoopConfig (PosLoopConfig & cfg)

Get the configuration values of the amplifiers position loop.

Parameters

<i>cfg</i>	A structure that will be filled with the config info.
------------	---

Returns

A pointer to an error object, or NULL on success

5.4.3.107 **const Error * GetProfileAcc (uunit & value)**

Get the profile acceleration value.

This parameter is specified in "user units". See [Amp::SetCountsPerUnit](#) for details.

Parameters

<i>value</i>	variable that will store the returned value
--------------	---

Returns

A pointer to an error object, or NULL on success

5.4.3.108 **const Error * GetProfileConfig (ProfileConfig & cfg)**

Load a structure with all parameters related to point-to-point moves.

Parameters

<i>cfg</i>	A structure where the configuration parameters will be returned.
------------	--

Returns

A pointer to an error object, or NULL on success

5.4.3.109 **const Error * GetProfileDec (uunit & value)**

Get the profile deceleration value.

This parameter is specified in "user units". See [Amp::SetCountsPerUnit](#) for details.

Parameters

<i>value</i>	variable that will store the returned value
--------------	---

Returns

A pointer to an error object, or NULL on success

5.4.3.110 **const Error * GetProfileJerk (uunit & value)**

Get the currently programmed jerk limit for S-curve profiles.

This parameter is specified in "user units". See [Amp::SetCountsPerUnit](#) for details.

Parameters

<i>value</i>	The location in which the jerk value will be returned.
--------------	--

Returns

A pointer to an error object, or NULL on success

5.4.3.111 `const Error * GetProfileType (PROFILE_TYPE & type)`

Get the currently selected motion profile type.

This profile type is used for point to point moves in which the amplifier calculates it's own trajectory.

Parameters

<i>type</i>	variable that will store the returned value
-------------	---

Returns

A pointer to an error object, or NULL on success

5.4.3.112 `const Error * GetProfileVel (uunit & value)`

Get the profile velocity value.

This parameter is specified in "user units". See [Amp::SetCountsPerUnit](#) for details.

Parameters

<i>value</i>	variable that will store the returned value
--------------	---

Returns

A pointer to an error object, or NULL on success

5.4.3.113 `const Error * GetPvtBuffFree (int16 & n)`

Get the number of free positions in the PVT segment buffer.

Parameters

<i>n</i>	A reference used to return the number of free positions
----------	---

Returns

A pointer to an error object, or NULL on success

5.4.3.114 `const Error * GetPvtBuffStat (uint32 & stat)`

Get the amplifier's PVT buffer status word.

Parameters

<i>stat</i>	A reference to a variable where the status will be returned
-------------	---

Returns

A pointer to an error object, or NULL on success

5.4.3.115 `const Error * GetPvtSegID (uint16 & id)`

Get the segment ID that the amplifier expects for the next PVT segment.

This starts at zero when the amp is reset, and is increased for every segment received.

Parameters

<i>id</i>	A reference to the variable where the ID will be written
-----------	--

Returns

A pointer to an error object, or NULL on success

5.4.3.116 `const Error * GetPvtSegPos (uint & pos)`

Get the starting position of the PVT segment currently active in the amplifier.

When running in PVT mode, this allows an approximation of the amplifier position to be retrieved without adding any additional overhead to the CANopen network.

The position returned by this function is only valid when running in PVT mode.

Parameters

<i>pos</i>	The position is returned here.
------------	--------------------------------

Returns

A pointer to an error object, or NULL on success.

5.4.3.117 `const Error * GetPwmInConfig (PwmInConfig & cfg)`

Upload the amplifier's PWM input pin configuration.

Parameters

<i>cfg</i>	A structure where the configuration parameters will be returned.
------------	--

Returns

A pointer to an error object, or NULL on success

5.4.3.118 `const Error * GetPwmMode (AMP_PWM_MODE & mode)`

Get the current PWM output mode configuration from the amplifier.

Parameters

<i>mode</i>	The mode information will be returned here.
-------------	---

Returns

A pointer to an error object, or NULL on success

5.4.3.119 `const Error * GetQuickStop (QUICK_STOP_MODE & mode)`

Get the quick stop mode.

This mode defines what happens when a quick stop command is issued to the amplifier.

Parameters

<i>mode</i>	The mode will be returned here.
-------------	---------------------------------

Returns

A pointer to an error object, or NULL on success

5.4.3.120 `const Error * GetQuickStopDec (uunit & value)`

Get the quick stop deceleration value.

This parameter is specified in "user units". See [Amp::SetCountsPerUnit](#) for details.

Parameters

<i>value</i>	variable that will store the returned value
--------------	---

Returns

A pointer to an error object, or NULL on success

5.4.3.121 `const Error * GetRefVoltage (int16 & value)`

Get the analog reference input voltage.

If the amplifier has an analog reference input, it's value will be returned in millivolts.

Parameters

<i>value</i>	The value will be returned in this variable
--------------	---

Returns

A pointer to an error object, or NULL on success

5.4.3.122 `const Error * GetRegenConfig (RegenConfig & cfg)`

Upload the current configuration parameters for the power regeneration resistor connected to the amplifier.

Note that not all amplifiers support a regen resistor. Please see the amplifier datasheet to determine if this feature is available for the amplifier being used.

Parameters

<i>cfg</i>	A structure where the configuration parameters will be returned.
------------	--

Returns

A pointer to an error object, or NULL on success

5.4.3.123 `const Error * GetSettlingTime (uint16 & value)`

Get the position window time value (milliseconds).

This timeout is used in conjunction with the position window value to identify when a motor has come to rest at the desired position.

Parameters

<i>value</i>	variable that will store the returned value
--------------	---

Returns

A pointer to an error object, or NULL on success

5.4.3.124 `const Error * GetSettlingWindow (uint & value)`

Get the position window value.

This window, along with the position window time value, is used to identify when the motor has come to rest at the desired position.

This parameter is specified in "user units". See [Amp::SetCountsPerUnit](#) for details.

Parameters

<i>value</i>	variable that will store the returned value
--------------	---

Returns

A pointer to an error object, or NULL on success

5.4.3.125 `const Error * GetSoftLimits (SoftPosLimit & cfg)`

Upload the current software limit switch settings from the amplifier.

Parameters

<i>cfg</i>	The limit switch settings will be returned in this structure.
------------	---

Returns

A pointer to an error object, or NULL on success.

5.4.3.126 NodeState GetState (void) [virtual]

Returns the present state of this node.

Note that this requires node guarding or heartbeats to be enabled.

Returns

The present node state.

Reimplemented from [Node](#).

5.4.3.127 const Error * GetStatusWord (uint16 & value)

Get the current value of the drive's status word.

The drive status word indicates the drives current state in it's internal state machine. The drives state in turn identifies if the drive is enabled / disabled, whether a fault is present on the drive, whether it is in motion, etc.

This status word is part of the CANopen device profile (DSP-402). It's used internally by the amplifier object.

Parameters

<i>value</i>	Returns the current status word value
--------------	---------------------------------------

Returns

A pointer to an error object, or NULL on success

5.4.3.128 const Error * GetTargetPos (uunit & value)

Get the profile target position.

This parameter is specified in "user units". See [Amp::SetCountsPerUnit](#) for details.

Parameters

<i>value</i>	variable that will store the returned value
--------------	---

Returns

A pointer to an error object, or NULL on success

5.4.3.129 const Error * GetTargetVel (uunit & value)

Get the target velocity used in profile velocity mode.

This parameter is specified in "user units". See [Amp::SetCountsPerUnit](#) for details.

Parameters

<i>value</i>	variable that will store the returned value
--------------	---

Returns

A pointer to an error object, or NULL on success

5.4.3.130 const Error * GetTorqueActual (int16 & value)

Get the actual torque being applied by the motor at the moment.

Parameters

<i>value</i>	The torque value is returned here. This is specified in thousandths of the motor rated torque (see Amp::SetTorqueTarget more more info).
--------------	--

Returns

A pointer to an error object, or NULL on success

5.4.3.131 const Error * GetTorqueDemand (int16 & value)

Get the torque demand value.

This is the torque that the amplifier is attempting to apply at the moment.

Parameters

<i>value</i>	The torque value is returned here. This is specified in thousandths of the motor rated torque (see Amp::SetTorqueTarget more more info).
--------------	--

Returns

A pointer to an error object, or NULL on success

5.4.3.132 const Error * GetTorqueRated (int32 & value)

Get the motor rated torque parameter.

The motor's rated torque is the amount of torque that the motor can continuously output without damage.

Parameters

<i>value</i>	The motor's rated torque in 0.001 Nm units. For linear motors the units are 0.001 N.
--------------	--

Returns

A pointer to an error object, or NULL on success

5.4.3.133 const Error * GetTorqueSlope (int32 & value)

Get the rate of change of torque for use in profile torque mode (AMPMODE_CAN_TORQUE).

Parameters

<i>value</i>	The rate of change specified in thousandths of the total rated torque per second.
--------------	---

Returns

A pointer to an error object, or NULL on success

5.4.3.134 `const Error * GetTorqueTarget (int16 & value)`

Get the current target torque value.

This parameter is used in profile torque mode (AMPMODE_CAN_TORQUE) to specify the torque that should be applied by the motor.

Parameters

<i>value</i>	The torque value is returned here. This is specified in thousandths of the motor rated torque (see Amp::SetTorqueTarget more more info).
--------------	--

Returns

A pointer to an error object, or NULL on success

5.4.3.135 `const Error * GetTraceChannel (uint8 ndx, AMP_TRACE_VAR & value)`

Get the amplifier variable current selected on one of the trace channels.

Parameters

<i>ndx</i>	The trace channel to get
<i>value</i>	The trace variable assigned to this channel will be returned here.

Returns

A pointer to an error object, or NULL on success

5.4.3.136 `const Error * GetTraceData (int32 * data, int32 & max)`

Upload any trace data captured in the amplifier.

Trace data should only be uploaded when the traces are stopped. Uploading data while it is currently being collected in the amplifier can cause corrupt data to be uploaded.

The trace data is returned as an array of 32-bit integer values. If there are N currently active trace channels, and M samples of data have been collected, then a total of N x M integer values will be returned. In this case, the samples for channel n (0 <= n < N) will be located at position n + m*N for 0 <= m < M.

Parameters

<i>data</i>	An array where the trace data will be returned.
<i>max</i>	On entry to this call, this parameter must hold the maximum number of 32-bit integer values to upload. On successful return this parameter will be filled with the total number of integers uploaded.

Returns

A pointer to an error object, or NULL on success

5.4.3.137 const Error * GetTraceMaxChannel (uint8 & max)

Return the maximum number of trace channels supported by the amplifier.

Parameters

<i>max</i>	The number of channels is returned here.
------------	--

Returns

A pointer to an error object, or NULL on success

5.4.3.138 const Error * GetTracePeriod (int16 & per)

Get the period of time between trace samples.

When the trace system is running, the amplifier will sample and store it's internal variables this often.

Note that this parameter specifies time in units of the amplifier's 'reference period'. See [Amp::GetTraceRefPeriod](#) for more information.

Parameters

<i>per</i>	The trace period is returned here.
------------	------------------------------------

Returns

A pointer to an error object, or NULL on success

5.4.3.139 const Error * GetTraceRefPeriod (int32 & per)

Get the 'reference period' used with the amplifiers trace mechanism.

The amplifier internally samples it's trace channels at integer multiples of this time.

For example, if the amplifier's reference period is 100,000 nanoseconds, then setting the trace period to 12 would indicate that the amplifier should sample it's internal variables every 1.2 milliseconds.

Parameters

<i>per</i>	The reference period is returned here in units of nanoseconds.
------------	--

Returns

A pointer to an error object, or NULL on success

5.4.3.140 `const Error * GetTraceStatus (AMP_TRACE_STATUS & stat, int16 & samp, int16 & sampMax)`

Get the current status of the amplifier's trace system.

Parameters

<i>stat</i>	Information on whether the trace is currently running is returned in this parameter.
<i>samp</i>	The total number of trace samples collected is returned here.
<i>sampMax</i>	The maximum number of trace samples that will fit in the internal buffer is returned here. This value will change depending on how many trace channels are active and which variables are selected.

Returns

A pointer to an error object, or NULL on success

5.4.3.141 `const Error * GetTraceTrigger (AMP_TRACE_TRIGGER & type, uint8 & chan, int32 & level, int16 & delay)`

Get the current configuration of the amplifier's trace trigger.

See [Amp::SetTraceTrigger](#) for more information about the trigger.

Parameters

<i>type</i>	The type of trigger to be used.
<i>chan</i>	Which trace channel to trigger off of.
<i>level</i>	The trigger level
<i>delay</i>	The delay between the occurrence of the trigger and the start of data collection.

Returns

A pointer to an error object, or NULL on success

5.4.3.142 `const Error * GetTrackingWindows (TrackingWindows & cfg)`

Get the configuration values of the amplifiers position & velocity tracking windows.

This function allows all tracking window paramters to be read from the amplifier as a group.

Parameters

<i>cfg</i>	A structure that will be filled with the config info.
------------	---

Returns

A pointer to an error object, or NULL on success

5.4.3.143 `const Error * GetTrajectoryAcc (uunit & value)`

Get the instantaneous commanded acceleration passed out of the trajectory generator.

This acceleration is used by the position loop to calculate it's acceleration feed forward term.

This parameter is specified in "user units". See [Amp::SetCountsPerUnit](#) for details.

Parameters

<i>value</i>	variable that will store the returned value
--------------	---

Returns

A pointer to an error object, or NULL on success

5.4.3.144 `const Error * GetTrajectoryVel (uunit & value)`

Get the instantaneous commanded velocity passed out of the trajectory generator. This velocity is used by the position loop to calculate it's velocity feed forward term. This parameter is specified in "user units". See [Amp::SetCountsPerUnit](#) for details.

Parameters

<i>value</i>	variable that will store the returned value
--------------	---

Returns

A pointer to an error object, or NULL on success

5.4.3.145 `const Error * GetUstepConfig (UstepConfig & cfg)`

Upload the current configuration parameters for the stepper.

Parameters

<i>cfg</i>	A structure where the configuration parameters will be returned.
------------	--

Returns

A pointer to an error object, or NULL on success

5.4.3.146 `const Error * GetVelLoopConfig (VelLoopConfig & cfg)`

Get the configuration values of the amplifiers velocity loop.

Parameters

<i>cfg</i>	A structure that will be filled with the config info.
------------	---

Returns

A pointer to an error object, or NULL on success

viDrain only in some firmware versions

5.4.3.147 `const Error * GetVelocityActual (uunit & value)`

Get the actual motor velocity.

The motor velocity is estimated by the amplifier based on the change in position seen at the encoder. For dual encoder systems, the load encoder velocity can be queried using the function [Amp::GetVelocityLoad](#).

This parameter is specified in "user units". See [Amp::SetCountsPerUnit](#) for details.

Parameters

<i>value</i>	variable that will store the returned value
--------------	---

Returns

A pointer to an error object, or NULL on success

5.4.3.148 `const Error * GetVelocityCommand (uunit & value)`

Get the commanded velocity.

The commanded velocity is the velocity value that is passed to the velocity limiter, and from there to the velocity control loop. If the amplifier is in position mode (i.e. the position loop is active), then this velocity is the output of the position control loop.

This parameter is specified in "user units". See [Amp::SetCountsPerUnit](#) for details.

Parameters

<i>value</i>	variable that will store the returned value
--------------	---

Returns

A pointer to an error object, or NULL on success

5.4.3.149 `const Error * GetVelocityLimited (uunit & value)`

Get the limited velocity.

This velocity is the result of applying the velocity limiter to the commanded velocity (see [GetVelocityCommand](#)).

When the velocity loop is being driven by the position loop, the velocity limiter consists of a maximum velocity value only. When some other source is driving the velocity loop, the limiter also includes a maximum acceleration and deceleration value.

This parameter is specified in "user units". See [Amp::SetCountsPerUnit](#) for details.

Parameters

<i>value</i>	variable that will store the returned value
--------------	---

Returns

A pointer to an error object, or NULL on success

5.4.3.150 `const Error * GetVelocityLoad (uunit & value)`

Get the load encoder velocity.

The load velocity is estimated by the amplifier based on the change in position seen at the load encoder. For dual encoder systems, the motor encoder velocity can be queried using the function [Amp::GetVelocityActual](#).

This parameter is specified in "user units". See [Amp::SetCountsPerUnit](#) for details.

Parameters

<i>value</i>	variable that will store the returned value
--------------	---

Returns

A pointer to an error object, or NULL on success

5.4.3.151 `const Error * GetVelocityProgrammed (uunit & vel)`

Get the programmed velocity value.

This parameter is the velocity that the amplifier will attempt to maintain when set to the mode AMPMODE_PROG_VEL.

Parameters

<i>vel</i>	The velocity will be returned here.
------------	-------------------------------------

Returns

A pointer to an error object, or NULL on success

5.4.3.152 `const Error * GetVelocityWarnTime (uint16 & value)`

Get the position window time value (milliseconds).

Parameters

<i>value</i>	variable that will store the returned value
--------------	---

Returns

A pointer to an error object, or NULL on success

5.4.3.153 `const Error * GetVelocityWarnWindow (uunit & value)`

Get the velocity warning window.

This parameter is specified in "user units". See [Amp::SetCountsPerUnit](#) for details.

Parameters

<i>value</i>	variable that will store the returned value
--------------	---

Returns

A pointer to an error object, or NULL on success

5.4.3.154 `const Error * GetVloopCommandFilter (Filter & f)`

Get the coefficients used in the velocity loop command filter.

Parameters

<i>f</i>	A structure where the filter coefficients will be returned
----------	--

Returns

A pointer to an error object, or NULL on success

5.4.3.155 `const Error * GetVloopOutputFilter (Filter & f)`

Get the coefficients used in the velocity loop output filter.

Parameters

<i>f</i>	A structure where the filter coefficients will be returned
----------	--

Returns

A pointer to an error object, or NULL on success

5.4.3.156 `const Error * GetVloopOutputFilter2 (Filter & f)`

Get the coefficients used in the second velocity loop output filter.

Parameters

<i>f</i>	A structure where the filter coefficients will be returned
----------	--

Returns

A pointer to an error object, or NULL on success

5.4.3.157 `const Error * GetVloopOutputFilter3 (Filter & f)`

Get the coefficients used in the third velocity loop output filter.

Parameters

<i>f</i>	A structure where the filter coefficients will be returned
----------	--

Returns

A pointer to an error object, or NULL on success

5.4.3.158 `const Error * GoHome (void)`

Execute a home move.

The various homing parameters (method, velocity, etc) are assumed to have already be configured.

Returns

A pointer to an error object, or NULL on success.

5.4.3.159 `const Error * GoHome (HomeConfig & cfg)`

Execute a home move.

The various homing parameters are passed in the [HomeConfig](#) structure.

This function simply programs all the homing parameters passed in the structure, then calls [Amp::GoHome\(\)](#).

Parameters

<i>cfg</i>	The homing configuration parameter structure.
------------	---

Returns

A pointer to an error object, or NULL on success.

5.4.3.160 `const Error * HaltMove (void)`

Halt the current move.

The exact type of halt can be programmed using the [Amp::SetHaltMode](#) function.

Note that the halt function is only available when running in one of the standard CAN amplifier modes. If doing low level velocity or current control, then moves must be stopped externally.

Returns

A pointer to an error object, or NULL on success.

5.4.3.161 `void HandleStateChange (NodeState from, NodeState to) [protected], [virtual]`

Handle an amplifier state change.

This method wakes up any task waiting on the move done semaphore in the event of a guard error. If this feature is desired, this method should be called from any class that over rides this method.

Parameters

<i>from</i>	Previous state of the Amp before the change
<i>to</i>	New state of the Amp

Reimplemented from [Node](#).

5.4.3.162 `const Error * Init (Network & net, int16 nodeID) [virtual]`

Initialize the amplifier object using all default settings.

Parameters

<i>net</i>	Reference to the Network for this amp.
<i>nodeID</i>	a valid node ID for the amp. For CANopen, the node ID should range from 1 to 127. For EtherCAT , node ID's ≥ 0 identify the node by it's EtherCAT alias. Negative ID's identify the node by network position (-1 is the first node, -2 is the second, etc).

Returns

A pointer to an error object, or NULL on success.

Reimplemented from [Node](#).

5.4.3.163 const Error * Init (Network & net, int16 nodeID, AmpSettings & settings)

Initialize the amplifier object with custom amp settings.

Parameters

<i>net</i>	Reference to the Network for this amp.
<i>nodeID</i>	a valid node ID for the amp
<i>settings</i>	Amplifier settings to be used.

Returns

A pointer to an error object, or NULL on success.

5.4.3.164 const Error * InitSubAxis (Amp & primary, int axis = 2)

Initialize an [Amp](#) object for use with a secondary axis of a multi-axis [EtherCAT](#) amplifier.

For Copley [EtherCAT](#) multi-axis drives (such as the AE2, BE2, etc), the drive is configured as a single node on the [EtherCAT](#) network with multiple axes of motion residing at that node. To control such a drive using CML, use a separate [Amp](#) object for each axis.

The first axis of such a drive is the primary axis and should be initialized using the normal [Amp::Init\(\)](#) function call just like a single axis amp. For any additional axes, use the [Amp::InitSubAxis\(\)](#) call and pass in a reference to the primary [Amp](#) object.

Note that multi-axis CANopen drives are normally configured as multiple distinct nodes on the CANopen network. Do not use this method to initialize nodes on a multi-axis CANopen drive, instead use the [Amp::Init\(\)](#) method for each [Amp](#) object.

Parameters

<i>primary</i>	Reference to the Amp object created for the primary (first) axis of the multi-axis EtherCAT drive.
<i>axis</i>	The axis number of the axis to be initialized. The axis number passed should be greater then or equal to two. Axis one is the primary axis and should be initialized using the Amp::Init() method.

Returns

A pointer to an error object, or NULL on success.

5.4.3.165 bool IsHardwareEnabled (void)

Return true if the amplifier's PWM outputs are currently enabled.

Returns

true if the amplifier's PWM outputs are currently enabled.

5.4.3.166 bool IsReferenced (void)

Return true if the amplifier has been successfully referenced (homed).

When an amplifier is first powered up (or after a reset) it does not know the absolute position of the motor. Once the home routine has been successfully executed, the encoder zero location is known and the amplifier is considered referenced.

Once an amplifier has been referenced, it will not lose reference until it is reset, or until a new home routine is executed. During the execution of a home routine, the amplifier is considered to be unreferenced. If the home routine is completed successfully, the amplifier will then be referenced again.

Returns

true if the amplifier has been referenced. Return false if the amplifier has not been referenced if an error occurs reading this information from the amplifier.

5.4.3.167 bool IsSoftwareEnabled (void)

Return true if the amplifier is being enabled by software.

The amplifier outputs may still be disabled if this is true due to an error condition, etc.

Returns

true if the amplifier is enabled by software.

5.4.3.168 uunit JrkLoad2User (int32 *jrk*) [virtual]

Convert a jerk value from internal amplifier units to user units.

Internal to the amplifier, all jerk values are stored in units of 100 encoder counts / second³. If user units are not enabled in [CML_Settings.h](#), then user units are the same as amplifier units, and this function has no effect.

If user units are enabled, then this function converts from amplifier units to user units (defined using [Amp::SetCountsPerUnit](#)).

For dual encoder systems the unit conversion used by this function is based on the load encoder resolution.

Parameters

<i>jrk</i>	The jerk value in units of 100 encoder counts / second ³
------------	---

Returns

The jerk in user units

5.4.3.169 int32 JrkUser2Load (uunit *jrk*) [virtual]

Convert a jerk value from user units to internal amplifier units.

Internal to the amplifier, all jerk values are stored in units of 100 encoder counts / second³. If user units are not enabled in [CML_Settings.h](#), then user units are the same as amplifier units, and this function has no effect.

If user units are enabled, then this function converts from user units (defined using [Amp::SetCountsPerUnit](#)) to these internal amplifier units.

For dual encoder systems the unit conversion used by this function is based on the load encoder resolution.

Parameters

<i>jrk</i>	The jerk in user units
------------	------------------------

Returns

The jerk in 100 encoder counts / second ³ units

5.4.3.170 `const Error * LoadFromFile (const char * name, int & line)`

Load the specified amplifier data file.

This function presently supports loading *.ccx files created by the CME-2 program, version 3.1 and later.

Parameters

<i>name</i>	The name (and optionally path) of the file to load
<i>line</i>	If not NULL, the last line number read from the file is returned here. This is useful for finding file format errors.

Returns

A pointer to an error object, or NULL on success.

5.4.3.171 `const Error* MoveAbs (uunit pos) [inline]`

Start an absolute point to point move to the specified position.

This is identical to calling `Amp::DoMove(pos)`

Parameters

<i>pos</i>	The position to move to
------------	-------------------------

Returns

A pointer to an error object, or NULL on success

5.4.3.172 `const Error* MoveRel (uunit dist) [inline]`

Start a relative point to point move of the specified distance.

This is identical to calling `Amp::DoMove(dist, true)`

Parameters

<i>dist</i>	The distance to move
-------------	----------------------

Returns

A pointer to an error object, or NULL on success

5.4.3.173 uunit PosLoad2User (int32 pos) [virtual]

Convert a position from internal amplifier units to user units.

Internal to the amplifier, all positions are stored in units of encoder counts. If user units are not enabled in [CML_Settings.h](#), then user units are also in encoder counts and this function has no effect.

If user units are enabled, then this function converts from amplifier units to user units (defined using [Amp::SetCountsPerUnit](#)).

For dual encoder systems the unit conversion used by this function is based on the load encoder resolution. To convert motor encoder positions, use [Amp::PosMtr2User](#). On single encoder systems either of these functions can be used.

Parameters

<i>pos</i>	The position in encoder counts
------------	--------------------------------

Returns

The position in user units

5.4.3.174 uunit PosMtr2User (int32 pos) [virtual]

Convert a position from internal amplifier units to user units.

This function converts using motor encoder units on a dual encoder system. Load encoder positions can be converted using [Amp::PosLoad2User](#).

Parameters

<i>pos</i>	The position in encoder counts
------------	--------------------------------

Returns

The position in user units

5.4.3.175 int32 PosUser2Load (uunit pos) [virtual]

Convert a position from user position units to internal amplifier units.

Internal to the amplifier, all positions are stored in units of encoder counts. If user units are not enabled in [CML_Settings.h](#), then user units are also in encoder counts and this function has no effect.

If user units are enabled at compile time, then this function converts from user units (defined using [Amp::SetCountsPerUnit](#)) to these internal amplifier units.

For dual encoder systems the unit conversion used by this function is based on the load encoder resolution. To convert motor encoder positions, use [Amp::PosUser2Mtr](#). On single encoder systems either of these functions can be used.

Parameters

<i>pos</i>	The position in user units
------------	----------------------------

Returns

The position in encoder counts

5.4.3.176 `int32 PosUser2Mtr (uint pos) [virtual]`

Convert a position from user position units to internal amplifier units.

This function converts using motor encoder units on a dual encoder system. Load encoder positions can be converted using [Amp::PosUser2Load](#).

Parameters

<i>pos</i>	The position in user units
------------	----------------------------

Returns

The position in encoder counts

5.4.3.177 `const Error * PvtBufferFlush (bool viaSDO = true) [protected]`

Flush the amplifier's PVT trajectory buffer.

Flushing the buffer in this way will cause any running profile to be aborted.

Parameters

<i>viaSDO</i>	If true, use a SDO to download the message. If false, use a PDO . default is true.
---------------	--

Returns

An error object.

5.4.3.178 `const Error * PvtBufferPop (uint16 n = 1, bool viaSDO = true) [protected]`

Pop the N most recently sent segments off the amplifier's PVT trajectory buffer.

If there are less than N segments on the buffer, then the buffer is cleared. Any profile running on the amplifier will continue to run (is not aborted) unless a buffer underflow occurs.

Parameters

<i>n</i>	The number of segments to pop off the buffer. Defaults to 1.
<i>viaSDO</i>	If true, use a SDO to download the message. If false, use a PDO . default is true.

Returns

An error object.

5.4.3.179 `const Error * PvtClearErrors (uint8 mask, bool viaSDO = true) [protected]`

Clear the specified PVT buffer errors.

Parameters

<i>mask</i>	A bit mask representing which PVT buffer errors to clear.
<i>viaSDO</i>	If true, use a SDO to download the message. If false, use a PDO . default is true.

Returns

An error object.

5.4.3.180 void PvtStatusUpdate (uint32 status)

This function is called by the PVT status [PDO](#) receiver function.

It takes care of the gory details of streaming out a trajectory that's too big to fit in the amplifier's PVT buffer all at once.

Parameters

<i>status</i>	The amplifier status word passed in the PDO
---------------	---

5.4.3.181 const Error * PvtWriteBuff (uint8 * buff, bool viaSDO = false) [protected]

Write to the PVT buffer on the amp.

We use a [PDO](#) to do this on CANopen, but use an [SDO](#) access on [EtherCAT](#).

Parameters

<i>buff</i>	Points to a buffer of formatted data to be sent. The buffer length must be at least 8 bytes.
<i>viaSDO</i>	Only used on CANopen. If true, download using an SDO .

Returns

A pointer to an error object, or NULL on success.

5.4.3.182 const Error * PvtWriteBuff (uint8 buff[][8], int ct, bool viaSDO = false) [protected]

Write multiple PVT buffers to the drive.

Parameters

<i>buff</i>	Points to a buffer of formatted data to be sent
<i>ct</i>	Number of buffers to write;
<i>viaSDO</i>	Only used on CANopen. If true, download using an SDO .

Returns

A pointer to an error object, or NULL on success.

5.4.3.183 const Error * QuickStop (void)

Perform a 'quick stop' on the axis.

The exact meaning of a quick stop can be programmed using the [Amp::SetQuickStop](#) function. Regardless of the type of quick stop being performed, the amplifier will always end up disabled at the end of the quick stop. If disabling the amplifier is not desirable, then the [Amp::HaltMove](#) function should be used instead.

Note that the quick stop function is only available when running in one of the standard CAN amplifier modes. If doing low level velocity or current control, then moves must be stopped externally.

Returns

A pointer to an error object, or NULL on success.

5.4.3.184 `const Error * Relnit (void)`

Re-initialize an amplifier.

This function simply calls [Amp::Init](#) using the same parameters that were initially passed.

Returns

A pointer to an error object, or NULL on success.

5.4.3.185 `const Error * Reset (void)`

Reset the amplifier object.

This function should be used for [Amp](#) objects instead of [Node::ResetNode\(\)](#). It resets the amplifier and re-initializes the amplifier object.

Returns

A pointer to an error object, or NULL on success.

5.4.3.186 `const Error * SaveAmpConfig (AmpConfig & cfg)`

Upload the passed amplifier configuration to the amplifier's workign memory, and then copy that working memory to flash.

Parameters

<i>cfg</i>	The structure which holds the new configuration.
------------	--

Returns

A pointer to an error object, or NULL on success

5.4.3.187 `const Error * SaveAmpConfig (void)`

Save all amplifier parameters to internal flash memory.

Flash memory is a type of non-volatile RAM which allows amplifier parameters to be saved between power cycles. When this function is called, any amplifier parameters that may be stored to flash will be copied from their working (RAM) locations to the stored (flash) locations.

For a list of those amplifier parameters which may be saved to flash memory, see the [AmpConfig](#) structure. Every member of that structure represents an amplifier parameter that may be saved to flash.

Returns

A pointer to an error object, or NULL on success

5.4.3.188 `const Error * SendTrajectory (Trajectory & trj, bool start = true)`

Upload a PVT move trajectory to the amplifier and optionally start the move.

Parameters

<i>trj</i>	Reference to the trajectory that will be feed to the amp. A local pointer to this trajectory will be stored if the entire profile will not fit in the amplifiers on-board buffer. This pointer will be kept until the entire profile has been uploaded to the amp. It is therefore important to ensure that the trajectory object will remain valid (i.e. not be deallocated) until the amplifier object has called the Trajectory.Finish() method on it.
<i>start</i>	If true (the default), the profile will be started by this call. If false, the profile will be uploaded, but not started. Use true if this is a single axis move, false if this is part of a multi-axis move which needs to be synchronized.

Returns

An error object.

Clear the PVT segment cache

Make sure the trajectory object is ready to go

5.4.3.189 `const Error * SetAlgoPhaseInit (AlgoPhaseInit & cfg)`

Download a new configuration structure for the algorithmic phase init.

Parameters

<i>cfg</i>	A structure containing the configuration parameters to set.
------------	---

Returns

A pointer to an error object, or NULL on success

5.4.3.190 `const Error * SetAmpConfig (AmpConfig & cfg)`

Update an amplifier's configuration from the passed structure.

The [AmpConfig](#) structure holds all amplifier parameters that may be stored in the amplifier's non-volatile flash memory. This function may be used to update all of these parameters in a single call.

Note that this function updates the copies of these variables in working RAM, not directly in the amplifier flash memory. To copy these parameters to non-volatile memory, call [Amp::SaveAmpConfig](#) after updating them.

Parameters

<i>cfg</i>	The structure which holds the new configuration.
------------	--

Returns

A pointer to an error object, or NULL on success

5.4.3.191 `const Error * SetAmpMode (AMP_MODE mode)`

Set the amplifier mode of operation.

The mode of operation determines the top level control loop that will be controled (position, velocity, or current), and the source of that control (CANopen network, digital input pins, etc).

Parameters

<i>mode</i>	The mode of operation to be set
-------------	---------------------------------

Returns

A pointer to an error object, or NULL on success.

5.4.3.192 **const Error * SetAmpName (char * name)**

Set the amplifier name stored in the amplifiers flash.

Parameters

<i>name</i>	The name of the drive to be set
-------------	---------------------------------

Returns

A pointer to an error object, or NULL on success

5.4.3.193 **const Error * SetAnalogCommandFilter (Filter & f)**

Set new coefficients for the analog reference input filter.

Parameters

<i>f</i>	A structure holding the filter coefficients
----------	---

Returns

A pointer to an error object, or NULL on success

5.4.3.194 **const Error * SetAnalogRefConfig (AnalogRefConfig & cfg)**

Configure the amplifier's analog reference input.

Note that some amplifier models do not support the analog reference.

Parameters

<i>cfg</i>	A structure holding the configuration to download
------------	---

Returns

A pointer to an error object, or NULL on success

5.4.3.195 **const Error * SetCammingConfig (CammingConfig & cfg)**

Download a new configuration structure for Camming.

Parameters

<i>cfg</i>	A structure containing the configuration parameters to set.
------------	---

Returns

A pointer to an error object, or NULL on success

5.4.3.196 `const Error * SetCanNetworkConfig (CanNetworkConfig & cfg)`

Set the CANopen node ID and bit rate configuration.

Note that the amplifier only uses this parameter at startup or after a reset.

Parameters

<i>cfg</i>	Structure holding the configuration to set.
------------	---

Returns

A pointer to an error object, or NULL on success

5.4.3.197 `const Error * SetControlWord (uint16 value)`

Set the amplifier's control word.

The control word is part of the CANopen device profile (DSP-402). It's used to enable/disable the amplifier, start moves, etc. This function is used internally by the [Amp](#) object.

Parameters

<i>value</i>	The control word value to set
--------------	-------------------------------

Returns

A pointer to an error object, or NULL on success

5.4.3.198 `const Error * SetCountsPerUnit (uint cts) [virtual]`

Configure the user programmable units.

Unit conversions may be enabled or disabled at compile time through a setting in [CML_Settings.h](#). If this feature is disabled, then all position, velocity, acceleration & jerk values are passed as 32-bit integers in the amplifier's native units:

- Position: Encoder counts
- Velocity: 0.1 encoder counts / second (i.e. 100 would be 10 counts/sec)
- Acceleration: 10 counts / second ² (i.e. 100 would be 1000 counts/sec²)
- Jerk: 100 counts / second ³ (i.e. 100 would be 10000 counts/sec³).

If unit conversions are enabled in [CML_Settings.h](#), then these values are passed as double precision floating point values, and this function may be used to set a scaling factor for these units. The scaling factor is passed to this function as a number of encoder counts / user distance unit.

Velocity units are always equal to distance units / second. Likewise, acceleration and jerk units are distance units / second² and distance units / second³.

For example, if the motor in question has a 1 micron encoder, then user units of meters, meters/sec, meters/sec², etc can be selected by passing a value of 1,000,000 to this function (i.e. the number of microns/meter).

When user units are enabled at compile time, the amplifier defaults to units of encoder counts, encoder counts / second, etc.

Parameters

<i>cts</i>	The number of encoder counts / user distance unit.
------------	--

Returns

A pointer to an error object, or NULL on success. Note that if user units are disabled in [CML_Settings.h](#), then this function will return an error.

5.4.3.199 `const Error * SetCountsPerUnit (uunit load, uunit mtr) [virtual]`

Configure the user programmable units for a dual encoder system.

This method provides the same feature as the single encoder version however it takes two scaling parameters; a load encoder scaler and a motor encoder scaler. These two values are used to scale amplifier parameters based on which encoder they refer to.

Parameters

<i>load</i>	The load encoder scaling factor. This gives the number of load encoder counts / user position unit.
<i>mtr</i>	The motor encoder scaling factor. This gives the number of motor encoder counts / user position unit.

Returns

A pointer to an error object, or NULL on success.

5.4.3.200 `const Error * SetCrntLoopConfig (CrntLoopConfig & cfg)`

Update the amplifier's current loop configuration.

Parameters

<i>cfg</i>	A structure that will be filled with the config info.
------------	---

Returns

A pointer to an error object, or NULL on success

5.4.3.201 `const Error * SetCurrentProgrammed (int16 crnt)`

Set the programmed current value in 0.01 [Amp](#) units.

This parameter is only used when running in the mode `AMPMODE_PROG_CRNT`. The value programmed through this variable is the current that the amplifier will attempt to output.

Parameters

<i>crnt</i>	The current to output (0.01 Amp units).
-------------	---

Returns

A pointer to an error object, or NULL on success

5.4.3.202 `const Error * SetDAConverterConfig (DAConfig & cfg)`

Set the D/A converter configuration.

Parameters

<i>cfg</i>	A structure holding the D/A converter configuration.
------------	--

Returns

A pointer to an error object, or NULL on success

5.4.3.203 `const Error * SetFaultMask (AMP_FAULT & value)`

Set the amplifier's fault mask.

The fault mask identifies which conditions will be treated as latching faults by the amplifier. If such a condition occurs, the amplifier's output will be disabled immediately, and will not be enabled until the fault condition is cleared.

Parameters

<i>value</i>	A bit mask identifying which fault conditions to latch.
--------------	---

Returns

A pointer to an error object, or NULL on success

5.4.3.204 `const Error * SetFuncGenConfig (FuncGenConfig & cfg)`

Configure the amplifier's internal function generator.

Parameters

<i>cfg</i>	A structure holding the configuration to download
------------	---

Returns

A pointer to an error object, or NULL on success

5.4.3.205 `const Error * SetGainScheduling (GainScheduling & cfg)`

Download a new configuration structure for Gain Scheduling.

Parameters

<i>cfg</i>	A structure containing the configuration parameters to set.
------------	---

Returns

A pointer to an error object, or NULL on success

5.4.3.206 `const Error * SetHaltMode (HALT_MODE mode)`

Set the halt mode.

When the amplifier's halt command is issued ([Amp::HaltMove](#)) the amplifier will attempt to stop the move in progress using the method defined by its halt mode.

Parameters

<i>mode</i>	The mode to set
-------------	-----------------

Returns

A pointer to an error object, or NULL on success

5.4.3.207 `const Error * SetHomeAccel (uunit value)`

Set the home acceleration.

This acceleration value will be used for all moves that are part of the home routine.

This parameter is specified in "user units". See [Amp::SetCountsPerUnit](#) for details.

Parameters

<i>value</i>	the value to set
--------------	------------------

Returns

A pointer to an error object, or NULL on success

5.4.3.208 `const Error * SetHomeConfig (HomeConfig & cfg)`

Configure the amplifier's homing related parameters.

The passed structure contains all parameters related to performing a home routine.

Parameters

<i>cfg</i>	A structure holding the configuration parameters.
------------	---

Returns

A pointer to an error object, or NULL on success

5.4.3.209 const Error * SetHomeCurrent (int16 value)

Set the home current.

The home current value is only used when homing to a hard stop. This parameter is specified in units of 0.01 Amps (i.e. a value of 123 would be 1.23 Amps).

Parameters

<i>value</i>	the value to set
--------------	------------------

Returns

A pointer to an error object, or NULL on success

5.4.3.210 const Error * SetHomeDelay (int16 value)

Set the home delay.

The home delay value is only used when homing to a hard stop. This parameter is specified in units of milliseconds.

Parameters

<i>value</i>	the value to set
--------------	------------------

Returns

A pointer to an error object, or NULL on success

5.4.3.211 const Error * SetHomeMethod (COPLEY_HOME_METHOD method, uint16 extended = 0)

Set the method used for homing the drive.

Parameters

<i>method</i>	The home method to set
<i>extended</i>	If the 'method' parameter is set to CHM_EXTENDED, then this value will be written to the extended homing parameter on the amplifier. For any other homing method this parameter is ignored.

Returns

A pointer to an error object, or NULL on success

5.4.3.212 const Error * SetHomeOffset (uint value)

Set the home offset value.

This offset is the difference between the location of the homing sensor (as defined by the homing method), and the actual zero position. Once the home location has been found, the amplifier will use this offset to determine where the zero position location is.

This parameter is specified in "user units". See [Amp::SetCountsPerUnit](#) for details.

Parameters

<i>value</i>	the value to set
--------------	------------------

Returns

A pointer to an error object, or NULL on success

5.4.3.213 `const Error * SetHomeVelFast (uunit value)`

Set the home velocity used to move to a home switch.

This velocity will be used for any move in the home routine that can be done at relatively high speed. A second slower velocity can also be programed for the parts of the home routine that are speed sensitive.

This parameter is specified in "user units". See [Amp::SetCountsPerUnit](#) for details.

Parameters

<i>value</i>	the value to set
--------------	------------------

Returns

A pointer to an error object, or NULL on success

5.4.3.214 `const Error * SetHomeVelSlow (uunit value)`

Set the home velocity used to find a switch edge.

This velocity will be used for any move in the home routine which is speed sensitive. This typically is a move in which the edge of a sensor is being searched for.

This parameter is specified in "user units". See [Amp::SetCountsPerUnit](#) for details.

Parameters

<i>value</i>	the value to set
--------------	------------------

Returns

A pointer to an error object, or NULL on success

5.4.3.215 `const Error * SetloopCommandFilter (Filter & f)`

Set the coefficients used in the current loop input filter.

Parameters

<i>f</i>	A structure holding the filter coefficients
----------	---

Returns

A pointer to an error object, or NULL on success

5.4.3.216 `const Error * SetIloopCommandFilter2 (Filter & f)`

Set the coefficients used in the second current loop input filter.

Parameters

<i>f</i>	A structure holding the filter coefficients
----------	---

Returns

A pointer to an error object, or NULL on success

5.4.3.217 `const Error * SetInputConfig (int8 pin, INPUT_PIN_CONFIG cfg, uint16 axis = 0)`

Set the input pin configuration for the specified input pin.

Each of the amplifier input pins can be configured to perform some function. This method configures the specified input to perform the specified function.

Parameters

<i>pin</i>	The input pin to configure. Input pins are numbered starting from 0. Check the amplifier datasheet for the number of input pins available.
<i>cfg</i>	The input pin function to be assigned to this pin.
<i>axis</i>	The axis to apply this input configuration to. This only applies to multi-axis drives. Default is 0 (first axis/axis A).

Returns

A pointer to an error object, or NULL on success

5.4.3.218 `const Error * SetInputDebounce (int8 pin, int16 value)`

Set the input pin debounce time for the specified input pin.

Each of the amplifier input pins can be configured ignore transient states that last less then the debounce time. This function configures the debounce time for a specific pin.

Parameters

<i>pin</i>	The input pin to configure. Input pins are numbered starting from 0. Check the amplifier datasheet for the number of input pins available.
<i>value</i>	The debounce time to use (milliseconds)

Returns

A pointer to an error object, or NULL on success

5.4.3.219 `const Error * SetInputShapingFilter (InputShaper & f)`

Set new coefficients for the input shaping filter.

Parameters

<i>f</i>	A structure holding the filter coefficients
----------	---

Returns

A pointer to an error object, or NULL on success

5.4.3.220 const Error * SetIoConfig (AmploCfg & cfg)

Configure the amplifier's programmable I/O pins using the values passed in the config structure.

The inputCt and outputCt values of the config structure should indicate the total number of input & output pins to configure. If the amplifier has more pins than these values indicate, the configuration of the remaining amplifier pins will not be changed.

Parameters

<i>cfg</i>	A structure that holds the configuration settings.
------------	--

Returns

A pointer to an error object, or NULL on success

5.4.3.221 const Error * SetIOOptions (int32 value)

Set the IO Options.

This parameter is used to configure the optional features of the general purpose IO. Bits 0-3 describe whether several IO pins are used as a serial interface for expanded IO features. 0 is normal IO, 1 is AEM/APM development board LEDs and address switches. 2 is LEDs wired the same as the developers kit board, but using separate red & green LEDs for network status.

Parameters

<i>value</i>	The new value for the IOOptions configuration
--------------	---

Returns

A pointer to an error object, or NULL on success

5.4.3.222 const Error * SetIoPullup (uint16 value)

Set the current state of the input pin pull up/down resistors.

Pull up/down resistors control how an undriven input pin will be interpreted by the amplifier. Depending on the model of amplifier being controlled, there may be zero or more groups of pull up/down resistors attached to some the input pins.

Each bit of this register is used to control one group of pull up/down resistors. Bit 0 controls group 0, etc.

Please refer to the amplifier data sheet for details on the number of groups of pull up/down resistors, and which input pins are included in each group.

Parameters

<i>value</i>	The new value to write to the pull up/down control register.
--------------	--

Returns

A pointer to an error object, or NULL on success

5.4.3.223 `const Error * SetloPullup32 (int32 value)`

32 Bit version of SetloPullup.

This is useful on drives that support more than 16 pull up/down resistors. Please see [Amp::SetloPullup\(\)](#) for more details.

Parameters

<i>value</i>	The new value to write to the pull up/down control register.
--------------	--

Returns

A pointer to an error object, or NULL on success

5.4.3.224 `const Error * SetMicrostepRate (int16 rate)`

Set the amplifier microstepping rate.

This parameter is only used in the diagnostic microstepping mode (AMPMODE_DIAG_USTEP).

Parameters

<i>rate</i>	The microstepping rate in degrees / second
-------------	--

Returns

A pointer to an error object, or NULL on success

5.4.3.225 `const Error * SetMtrInfo (MtrInfo & info)`

Update the amplifier's motor information.

Parameters

<i>info</i>	A structure that contains the motor info to be downloaded.
-------------	--

Returns

A pointer to an error object, or NULL on success

5.4.3.226 `const Error * SetNetworkOptions (NetworkOptions & cfg)`

Set the [Network](#) Options configuration.

Parameters

<i>cfg</i>	Reference to the NetworkOptions structure containing the configuration data to be written to the amp.
------------	---

Returns

A pointer to an error object, or NULL on success

5.4.3.227 `const Error * SetOutputConfig (int8 pin, OUTPUT_PIN_CONFIG cfg, uint32 param1 = 0, uint32 param2 = 0, uint16 axis = 0)`

Set the output pin configuration for the specified pin.

Each of the amplifier output pins can be configured to perform some function. These functions break down into several basic modes:

- manual mode: In this mode, the output pin will be controlled through the CANopen network using the [Amp::Set-Outputs](#) function. Output pins can be configured to be either active high or active low in this mode.
- Status word tracking: In this mode, the output pin is configured to track one or more bits of one of the amplifier's internal status words. A 32-bit mask is also supplied which identifies which bits are to be tracked. If any of the selected bits are set in the status word, the output pin will go active.
- Position trigger. In this mode the output pin will be configured to go active based on the position of the motor. In some cases the output will go active between two programmed positions. In other cases the output will be triggered by crossing a position and will stay active for a programmed duration.

Parameters

<i>pin</i>	The output pin to configure. Output pins are numbered starting from 0. Check the amplifier datasheet for the number of output pins available.
<i>cfg</i>	The pin function to be assigned to this pin.
<i>param1</i>	A 32-bit parameter used in conjunction with the output pin configuration to define the pin behavior. For most simple output pin modes this parameter is a bitmask that selects bits in a status register that the output should track. If the output pin is being configured for manual mode, then the mask is not used and does not need to be specified.
<i>param2</i>	A second 32-bit parameter used in a few output pin configurations.
<i>axis</i>	On multi-axis drives this is used to configure which axis this output pin is configured for.

Returns

A pointer to an error object, or NULL on success

5.4.3.228 `const Error * SetOutputs (uint16 value)`

Update the state of the manual output pins.

The passed value will be written to the output pin control register. Any of the output pins that have been configured as manual outputs will be updated based on the value of this register.

Bit 0 controls output pin 0, bit 1 sets output pin 1, etc.

Note that only those output pins that have been configured as manual outputs are effected by this command. Output pins that are configured to perform some other function (such as tracking bits in the event status register) are not effected. See [Amp::SetOutputConfig](#) for details on configuring the amplifier output pins.

Also note that this pin controls the active/inactive state of the outputs, not the high/low state. Each output pin can be individually configured as active high or active low. Setting a bit in the register to 1 sets the corresponding output pin active. Active high/low configuration is set using [Amp::SetOutputConfig](#).

Parameters

<i>value</i>	The new value to write to the output pin control register.
--------------	--

Returns

A pointer to an error object, or NULL on success

5.4.3.229 `const Error * SetPhaseMode (AMP_PHASE_MODE mode)`

Set the phasing mode configuration for the amplifier.

Parameters

<i>mode</i>	The phasing mode to set
-------------	-------------------------

Returns

A pointer to an error object, or NULL on success

5.4.3.230 `const Error * SetPosCaptureCfg (POS_CAPTURE_CFG cfg)`

Set the position capture configuration.

The position capture mechanism in the amplifier allows the motor position to be captured by some event. The position can be captured by a transition on the encoder index signal, or by a transition on a general purpose input pin which has been configured as a 'home' input.

Parameters

<i>cfg</i>	The position capture configuration value is passed here.
------------	--

Returns

A pointer to an error object, or NULL on success

5.4.3.231 `const Error * SetPositionActual (uunit value)`

Set the actual position.

On dual encoder systems, this will set the load encoder position. [Amp::SetPositionMotor](#) may be used to set the motor position on such systems.

This parameter is specified in "user units". See [Amp::SetCountsPerUnit](#) for details.

Parameters

<i>value</i>	The actual position of the motor.
--------------	-----------------------------------

Returns

A pointer to an error object, or NULL on success

5.4.3.232 `const Error * SetPositionErrorWindow (uunit value)`

Set the position error window.

If the absolute value of the motor's position error ever exceeds this value, then a tracking error will occur.

A tracking error causes the amplifier to abort any move in progress, and attempt to bring the motor to a stop using its velocity loop. The commanded velocity input to the velocity loop will be driven to zero, subject to the velocity loop acceleration and deceleration limits.

This parameter is specified in "user units". See [Amp::SetCountsPerUnit](#) for details.

Parameters

<i>value</i>	The value to use for the position error window.
--------------	---

Returns

A pointer to an error object, or NULL on success

5.4.3.233 `const Error * SetPositionLoad (uunit value)`

Set the load encoder position.

On single encoder systems, this value is NOT USED.

For dual encoder systems, this will set the load encoder position. This is also the passive load position when the load encoder is configured to be in passive mode.

This parameter is specified in "user units". See [Amp::SetCountsPerUnit](#) for details.

Parameters

<i>value</i>	The actual position of the motor.
--------------	-----------------------------------

Returns

A pointer to an error object, or NULL on success

5.4.3.234 `const Error * SetPositionMotor (uunit value)`

Set the actual motor position.

On dual encoder systems, this will set the motor encoder position. [Amp::SetPositionActual](#) may be used to set the load position on such systems.

Parameters

<i>value</i>	The actual position of the motor.
--------------	-----------------------------------

Returns

A pointer to an error object, or NULL on success

5.4.3.235 `const Error * SetPositionWarnWindow (uunit value)`

Set the position warning window.

If the absolute value of the position error ever exceeds this value, then a tracking warning will result. A tracking warning causes a bit in the drives status to be set.

This parameter is specified in "user units". See [Amp::SetCountsPerUnit](#) for details.

Parameters

<i>value</i>	the value to set
--------------	------------------

Returns

A pointer to an error object, or NULL on success

5.4.3.236 `const Error * SetPosLoopConfig (PosLoopConfig & cfg)`

Update the amplifier's position loop configuration.

Parameters

<i>cfg</i>	A structure that will be filled with the config info.
------------	---

Returns

A pointer to an error object, or NULL on success

5.4.3.237 `const Error * SetProfileAcc (uunit value)`

Set the profile acceleration value (i.e.

the acceleration that the motor will normally attain when starting the move).

This parameter is specified in "user units". See [Amp::SetCountsPerUnit](#) for details.

Parameters

<i>value</i>	The value to set.
--------------	-------------------

Returns

A pointer to an error object, or NULL on success

5.4.3.238 `const Error * SetProfileConfig (ProfileConfig & cfg)`

Configure the amplifier's parameters related to point-to-point moves.

Parameters

<i>cfg</i>	A structure holding the configuration parameters.
------------	---

Returns

A pointer to an error object, or NULL on success

5.4.3.239 **const Error * SetProfileDec (uunit value)**

Set the profile deceleration value (i.e.

the acceleration that the motor will normally attain when ending the move).

Note that S-curve profiles don't use a separate deceleration value. For S-curve moves, the value programmed in SetProfileAcc is also used for the deceleration segment at the end of the move.

This parameter is specified in "user units". See [Amp::SetCountsPerUnit](#) for details.

Parameters

<i>value</i>	The value to set.
--------------	-------------------

Returns

A pointer to an error object, or NULL on success

5.4.3.240 **const Error * SetProfileJerk (uunit value)**

Set the jerk limit used with S-curve profiles.

Jerk is the rate of change of acceleration.

Note that this value is only used with S-curve profiles. Trapezoidal profiles do not limit jerk (i.e. they allow instantaneous changes in acceleration).

This parameter is specified in "user units". See [Amp::SetCountsPerUnit](#) for details.

Parameters

<i>value</i>	The jerk value to set
--------------	-----------------------

Returns

A pointer to an error object, or NULL on success

5.4.3.241 **const Error * SetProfileType (PROFILE_TYPE type)**

Set the motion profile type.

The motion profile type is only used when running in 'position profile' mode. In this mode, the drive performs point to point moves using it's internal trajectory generator.

The motion profile type defines the type of trajectory profile that the drive will generate.

Parameters

<i>type</i>	The profile type to use
-------------	-------------------------

Returns

A pointer to an error object, or NULL on success

5.4.3.242 `const Error * SetProfileVel (uunit value)`

Set the profile velocity value (i.e. the velocity that the motor will normally attain during the move).

This parameter is specified in "user units". See [Amp::SetCountsPerUnit](#) for details.

Parameters

<i>value</i>	The value to set.
--------------	-------------------

Returns

A pointer to an error object, or NULL on success

5.4.3.243 `const Error * SetPvtInitialPos (int32 pos, bool viaSDO =true) [protected]`

Set the initial position for a PVT trajectory.

This function sends a full 32-bit position value which can be used to start a PVT move beyond the 24-bit limit of normal segments. It's normally used at the beginning of a PVT trajectory when the starting position is greater than 24-bits and the commanded position at the time of the move's start is not obvious.

Parameters

<i>pos</i>	The 32-bit initial position
<i>viaSDO</i>	If true, use a SDO to download the message. If false, use a PDO . default is true.

Returns

An error object

5.4.3.244 `const Error * SetPwmInConfig (PwmInConfig & cfg)`

Configure the amplifier's PWM input pins.

Note that these settings are only used when the amplifier is controlled by its PWM (or pulse/direction) input pins, i.e. not in CANopen mode.

Parameters

<i>cfg</i>	A structure holding the configuration to download
------------	---

Returns

A pointer to an error object, or NULL on success

5.4.3.245 const Error * SetPwmMode (AMP_PWM_MODE mode)

Set the PWM output mode configuration for the amplifier.

Parameters

<i>mode</i>	The PWM output mode to set
-------------	----------------------------

Returns

A pointer to an error object, or NULL on success

5.4.3.246 const Error * SetQuickStop (QUICK_STOP_MODE mode)

Set the quick stop mode.

When the amplifier's quick stop command is issued ([Amp::QuickStop](#)), the amplifier will attempt to stop the move in progress using the method defined by its quick stop mode.

Parameters

<i>mode</i>	The mode to set
-------------	-----------------

Returns

A pointer to an error object, or NULL on success

5.4.3.247 const Error * SetQuickStopDec (uunit value)

Set the quick stop deceleration value (i.e.

the acceleration that the motor will use when doing a quick stop).

This parameter is specified in "user units". See [Amp::SetCountsPerUnit](#) for details.

Parameters

<i>value</i>	The value to set.
--------------	-------------------

Returns

A pointer to an error object, or NULL on success

5.4.3.248 const Error * SetRegenConfig (RegenConfig & cfg)

Download a new configuration structure for the power regeneration resistor.

Note that not all amplifiers support a regen resistor. Please see the amplifier datasheet to determine if this feature is available for the amplifier being used.

Parameters

<i>cfg</i>	A structure containing the configuration parameters to set.
------------	---

Returns

A pointer to an error object, or NULL on success

5.4.3.249 **const Error * SetSettlingTime (uint16 value)**

Set the position window time value (milliseconds).

The drive will be considered to be settled in position after a move when it's absolute position error value has been within the position window for an amount of time greater then the position window time value.

Parameters

<i>value</i>	the value to set
--------------	------------------

Returns

A pointer to an error object, or NULL on success

5.4.3.250 **const Error * SetSettlingWindow (uint value)**

Set the position settling window.

The drive will be considered to be settled in position after a move when it's absolute position error value has been within the position window for an amount of time greater then the position window time value.

This parameter is specified in "user units". See [Amp::SetCountsPerUnit](#) for details.

Parameters

<i>value</i>	the value to set
--------------	------------------

Returns

A pointer to an error object, or NULL on success

5.4.3.251 **const Error * SetSoftLimits (SoftPosLimit & cfg)**

Set software limit switch settings.

The amplifier's software limit settings consist of a positive and negative absolute position. Any time the motors actual position is greater then the positive limit, or less then the negative limit, a limit event occurs. Software limit events are treated by the amplifier in the same way that physical limit switches are, no current will be output in the direction of the limit switch, and any running trajectory will be aborted.

Software limit switches are not used until the amplifier has been homed. Also, if the positive software limit is set to a value greater then or equal to the negative software limit, then the limits are disabled.

Parameters

<i>cfg</i>	The limit switch settings to use
------------	----------------------------------

Returns

A pointer to an error object, or NULL on success.

5.4.3.252 **const Error * SetTargetPos (uunit value)**

Set the profile target position (i.e. the position to which the motor should move).

For relative moves, this function sets the distance to move.

This parameter is specified in "user units". See [Amp::SetCountsPerUnit](#) for details.

Parameters

<i>value</i>	The position to move to
--------------	-------------------------

Returns

A pointer to an error object, or NULL on success

5.4.3.253 **const Error * SetTargetVel (uunit value)**

Set the target velocity used in profile velocity mode.

This parameter is only used when the amplifier is set to profile velocity mode (AMPMODE_CAN_VELOCITY). When in this mode, this parameter defines the target velocity for motion.

This parameter is specified in "user units". See [Amp::SetCountsPerUnit](#) for details.

Parameters

<i>value</i>	The new target velocity.
--------------	--------------------------

Returns

A pointer to an error object, or NULL on success

5.4.3.254 **const Error * SetTorqueRated (int32 value)**

Set the motor rated torque parameter.

The motor's rated torque is the amount of torque that the motor can continuously output without damage.

Parameters

<i>value</i>	The motor's rated torque in 0.001 Nm units. For linear motors the units are 0.001 N.
--------------	--

Returns

A pointer to an error object, or NULL on success

5.4.3.255 const Error * SetTorqueSlope (int32 value)

Set the rate of change of torque for use in profile torque mode (AMPMODE_CAN_TORQUE).

Setting this parameter to zero will cause the rate of change to be unlimited.

Parameters

<i>value</i>	The rate of change specified in thousandths of the total rated torque per second. For example, setting to 1000 would specify a slope of the full rated torque of the motor every second.
--------------	--

Returns

A pointer to an error object, or NULL on success

5.4.3.256 const Error * SetTorqueTarget (int16 value)

Set the amplifier target torque value.

This parameter is used in profile torque mode (AMPMODE_CAN_TORQUE) to specify the desired target torque value. The actual torque commanded by the amplifier will ramp up/down to this value based on the programmed torque slope (see [Amp::SetTorqueSlope](#)).

The units used for this object are based on the CANopen DS402 specification. An applications note is available on Copley's web site which gives more information on exactly how to convert between these torque units and the commanded current in the drive. <http://www.copleycontrols.com/Motion/pdf/Current-Scaling.pdf>

Parameters

<i>value</i>	The torque value to be set. This is specified in thousandths of the motor rated torque.
--------------	---

Returns

A pointer to an error object, or NULL on success

5.4.3.257 const Error * SetTraceChannel (uint8 ndx, AMP_TRACE_VAR value)

Select an amplifier trace variable to be sampled.

Parameters

<i>ndx</i>	The trace channel that the variable will be assigned to.
<i>value</i>	The trace variable to sample.

Returns

A pointer to an error object, or NULL on success

5.4.3.258 `const Error * SetTracePeriod (int16 per)`

Set the period of time between trace samples.

When the trace system is running, the amplifier will sample and store it's internal variables this often.

Note that this parameter specifies time in units of the amplifier's 'reference period'. See [Amp::GetTraceRefPeriod](#) for more information.

Parameters

<i>per</i>	The trace period to be set.
------------	-----------------------------

Returns

A pointer to an error object, or NULL on success

5.4.3.259 `const Error * SetTraceTrigger (AMP_TRACE_TRIGGER type, uint8 chan = 0, int32 level = 0, int16 delay = 0)`

Configure the amplifier's trace trigger.

The trigger acts something like the trigger on an oscilloscope. It allows some event to be specified which will cause the trace subsystem to start collecting data. Most trigger types watch one of the trace channels and constantly compare it's value to a level. The type of comparison made will depend on the type of trigger. For example, the trace can be triggered on the rising edge of a signal, on the falling edge, etc.

The trigger also allows a delay value to be specified. Trace data will start to be collected N trace periods after the trigger, where N is the delay value. The delay can also be negative, in which case the data will start to be collected before the trigger event.

Parameters

<i>type</i>	The trigger type.
<i>chan</i>	The trace channel to watch. This parameter defaults to 0 if not specified.
<i>level</i>	The trigger level. This parameter defaults to 0 if not specified.
<i>delay</i>	The trigger delay in trace sample periods. Defaults to 0 if not specified.

Returns

A pointer to an error object, or NULL on success

5.4.3.260 `const Error * SetTrackingWindows (TrackingWindows & cfg)`

Update the amplifier's tracking window configuration.

This function allows all tracking window parameters to be configured with one function call.

Parameters

<i>cfg</i>	A structure that holds the configuration settings.
------------	--

Returns

A pointer to an error object, or NULL on success

5.4.3.261 const Error * SetupMove (ProfileConfigTrap & cfg)

Setup a point to point move, but do not start it.

The move may be subsequently started using [Amp::StartMove\(\)](#).

The move will use the trapezoidal profile mode, and all parameters will be programmed based on the values passed in the `cfg` structure.

Parameters

<i>cfg</i>	A structure holding all the move configuration parameters.
------------	--

Returns

A pointer to an error object, or NULL on success.

5.4.3.262 const Error * SetupMove (ProfileConfigScurve & cfg)

Setup a point to point move, but do not start it.

The move may be subsequently started using [Amp::StartMove\(\)](#).

The move will use the S-curve profile mode, and all parameters will be programmed based on the values passed in the `cfg` structure.

Parameters

<i>cfg</i>	A structure holding all the move configuration parameters.
------------	--

Returns

A pointer to an error object, or NULL on success.

5.4.3.263 const Error * SetupMove (ProfileConfigVel & cfg)

Setup a point to point move, but do not start it.

The move may be subsequently started using [Amp::StartMove\(\)](#).

The move will use the velocity profile mode, and all parameters will be programmed based on the values passed in the `cfg` structure.

Parameters

<i>cfg</i>	A structure holding all the move configuration parameters.
------------	--

Returns

A pointer to an error object, or NULL on success.

5.4.3.264 const Error * SetUstepConfig (UstepConfig & cfg)

Download a new configuration structure for the microstepper.

Parameters

<i>cfg</i>	A structure containing the configuration parameters to set.
------------	---

Returns

A pointer to an error object, or NULL on success

5.4.3.265 **const Error * SetVelLoopConfig (VelLoopConfig & *cfg*)**

Update the amplifier's velocity loop configuration.

Parameters

<i>cfg</i>	A structure that will be filled with the config info.
------------	---

Returns

A pointer to an error object, or NULL on success

viDrain only in some firmware versions

5.4.3.266 **const Error * SetVelocityProgrammed (*uunit vel*)**

Set the programmed velocity value.

This parameter is only used when running in the mode AMPMODE_PROG_VEL. The value programmed through this variable is the velocity that the amplifier will attempt to output.

Parameters

<i>vel</i>	The velocity to output.
------------	-------------------------

Returns

A pointer to an error object, or NULL on success

5.4.3.267 **const Error * SetVelocityWarnTime (*uint16 value*)**

Set the velocity warning window time value (milliseconds).

If the velocity error exceeds the velocity warning window, then a bit will be set in the amplifier status word. This bit will not be cleared until the velocity error has been within the warning window for at least this long.

Parameters

<i>value</i>	the value to set
--------------	------------------

Returns

A pointer to an error object, or NULL on success

5.4.3.268 `const Error * SetVelocityWarnWindow (uunit value)`

Set the velocity warning window.

If the absolute value of the velocity error exceeds this value, then a velocity warning will result. A velocity warning causes a bit in the drives status to be set.

This parameter is specified in "user units". See [Amp::SetCountsPerUnit](#) for details.

Parameters

<i>value</i>	the value to set
--------------	------------------

Returns

A pointer to an error object, or NULL on success

5.4.3.269 `const Error * SetVloopCommandFilter (Filter & f)`

Set new coefficients for the velocity loop command filter.

Parameters

<i>f</i>	A structure holding the filter coefficients
----------	---

Returns

A pointer to an error object, or NULL on success

5.4.3.270 `const Error * SetVloopOutputFilter (Filter & f)`

Set new coefficients for the velocity loop output filter.

Parameters

<i>f</i>	A structure holding the filter coefficients
----------	---

Returns

A pointer to an error object, or NULL on success

5.4.3.271 `const Error * SetVloopOutputFilter2 (Filter & f)`

Set the coefficients used in the second velocity loop output filter.

Parameters

<i>f</i>	A structure holding the filter coefficients
----------	---

Returns

A pointer to an error object, or NULL on success

5.4.3.272 `const Error * SetVloopOutputFilter3 (Filter & f)`

Set the coefficients used in the third velocity loop output filter.

Parameters

<i>f</i>	A structure holding the filter coefficients
----------	---

Returns

A pointer to an error object, or NULL on success

5.4.3.273 `const Error * StartMove (bool relative = false)`

Start the move that's already been programmed.

This function is primarily intended for internal use, and is called by DoMove and SendTrajectory. Note that the amplifier mode must have already been setup when this function is called. The mode should be either AMPMODE_CAN_PROFILE, or AMPMODE_CAN_PVT. This function is not used to start a homing move.

Parameters

<i>relative</i>	If true, start a relative move. If false, start an absolute move. Note that this is only used with point to point moves, interpolated moves should always set relative to false.
-----------------	--

Returns

A pointer to an error object, or NULL on success.

5.4.3.274 `const Error * StartPVT (void)`

Start a PVT move that has already been uploaded.

Returns

A pointer to an error object, or NULL on success.

5.4.3.275 `const Error * TraceStart (void)`

Start collecting trace data on the amplifier.

The trace will automatically stop once the amplifier's internal trace buffer fills up.

Returns

A pointer to an error object, or NULL on success

5.4.3.276 `const Error * TraceStop (void)`

Stop collecting trace data on the amplifier.

Returns

A pointer to an error object, or NULL on success

5.4.3.277 `const Error * UpdateEvents (uint16 stat, uint32 events, uint16 inputs)`

Update the amplifier's event map based on the status information received by a status [PDO](#).

This function is intended for internal use and shouldn't generally be called by user code.

Parameters

<i>stat</i>	The CANopen status word
<i>events</i>	The Event status word
<i>inputs</i>	The current state of the first 16 input pins

Returns

Null on success, or an error object on failure

5.4.3.278 `const Error * Upld16 (int16 index, int16 sub, uint16 & data)`

Upload data from an object in this Amps object dictionary.

The object number is adjusted based on the axis number if necessary.

Parameters

<i>index</i>	The index of the object to be downloaded.
<i>sub</i>	The sub-index of the object to be downloaded.
<i>data</i>	The uploaded data will be returned here.

Returns

A pointer to an error object, or NULL on success

5.4.3.279 `const Error * Upld16 (int16 index, int16 sub, int16 & data)`

Upload data from an object in this Amps object dictionary.

The object number is adjusted based on the axis number if necessary.

Parameters

<i>index</i>	The index of the object to be downloaded.
<i>sub</i>	The sub-index of the object to be downloaded.
<i>data</i>	The uploaded data will be returned here.

Returns

A pointer to an error object, or NULL on success

5.4.3.280 `const Error * Upld32 (int16 index, int16 sub, uint32 & data)`

Upload data from an object in this Amps object dictionary.

The object number is adjusted based on the axis number if necessary.

Parameters

<i>index</i>	The index of the object to be downloaded.
<i>sub</i>	The sub-index of the object to be downloaded.
<i>data</i>	The uploaded data will be returned here.

Returns

A pointer to an error object, or NULL on success

5.4.3.281 const Error * Upld32 (int16 index, int16 sub, int32 & data)

Upload data from an object in this Amps object dictionary.

The object number is adjusted based on the axis number if necessary.

Parameters

<i>index</i>	The index of the object to be downloaded.
<i>sub</i>	The sub-index of the object to be downloaded.
<i>data</i>	The uploaded data will be returned here.

Returns

A pointer to an error object, or NULL on success

5.4.3.282 const Error * Upld8 (int16 index, int16 sub, uint8 & data)

Upload data from an object in this Amps object dictionary.

The object number is adjusted based on the axis number if necessary.

Parameters

<i>index</i>	The index of the object to be downloaded.
<i>sub</i>	The sub-index of the object to be downloaded.
<i>data</i>	The uploaded data will be returned here.

Returns

A pointer to an error object, or NULL on success

5.4.3.283 const Error * Upld8 (int16 index, int16 sub, int8 & data)

Upload data from an object in this Amps object dictionary.

The object number is adjusted based on the axis number if necessary.

Parameters

<i>index</i>	The index of the object to be downloaded.
--------------	---

<i>sub</i>	The sub-index of the object to be downloaded.
<i>data</i>	The uploaded data will be returned here.

Returns

A pointer to an error object, or NULL on success

5.4.3.284 const Error * UpldString (int16 index, int16 sub, int32 & len, char * data)

Upload data from an object in this Amps object dictionary.

The object number is adjusted based on the axis number if necessary.

Parameters

<i>index</i>	The index of the object to be downloaded.
<i>sub</i>	The sub-index of the object to be downloaded.
<i>len</i>	Holds the size of the buffer on entry, and the length of the downloaded data on return.
<i>data</i>	The uploaded data will be returned here.

Returns

A pointer to an error object, or NULL on success

5.4.3.285 const Error * Upload (int16 index, int16 sub, int32 & size, byte * data)

Upload data from an object in this Amps object dictionary.

The object number is adjusted based on the axis number if necessary.

Parameters

<i>index</i>	The index of the object to be downloaded.
<i>sub</i>	The sub-index of the object to be downloaded.
<i>size</i>	On entry, this gives the maximum number of bytes of data to be uploaded. On successful return, it gives the actual number of bytes received.
<i>data</i>	A character array which will store the uploaded data.

Returns

A pointer to an error object, or NULL on success

5.4.3.286 uunit VelLoad2User (int32 vel) [virtual]

Convert a velocity from internal amplifier units to user units.

Internal to the amplifier, all velocities are stored in units of 0.1 encoder counts / second. If user units are not enabled in [CML_Settings.h](#), then user units are the same as amplifier units, and this function has no effect.

If user units are enabled, then this function converts from amplifier units to user units (defined using [Amp::SetCountsPerUnit](#)).

For dual encoder systems the unit conversion used by this function is based on the load encoder resolution. To convert motor encoder velocities, use [Amp::VelMtr2User](#). On single encoder systems either of these functions can be used.

Parameters

<i>vel</i>	The velocity in 0.1 encoder counts / second
------------	---

Returns

The velocity in user units

5.4.3.287 uunit VelMtr2User (int32 *vel*) [virtual]

Convert a velocity from internal amplifier units to user units.

This function converts using motor encoder units on a dual encoder system. Load encoder velocities can be converted using [Amp::VelLoad2User](#).

Parameters

<i>vel</i>	The velocity in 0.1 encoder counts / second
------------	---

Returns

The velocity in user units

5.4.3.288 int32 VelUser2Load (uunit *vel*) [virtual]

Convert a velocity from user units to internal amplifier units.

Internal to the amplifier, all velocities are stored in units of 0.1 encoder counts / second. If user units are not enabled in [CML_Settings.h](#), then user units are the same as amplifier units, and this function has no effect.

If user units are enabled, then this function converts from user units (defined using [Amp::SetCountsPerUnit](#)) to these internal amplifier units.

For dual encoder systems the unit conversion used by this function is based on the load encoder resolution. To convert motor encoder velocities, use [Amp::VelUser2Mtr](#). On single encoder systems either of these functions can be used.

Parameters

<i>vel</i>	The velocity in user units
------------	----------------------------

Returns

The velocity in 0.1 encoder counts / second

5.4.3.289 int32 VelUser2Mtr (uunit *vel*) [virtual]

Convert a velocity from user units to internal amplifier units.

This function converts using motor encoder units on a dual encoder system. Load encoder velocities can be converted using [Amp::VelUser2Load](#).

Parameters

<i>vel</i>	The velocity in user units
------------	----------------------------

Returns

The velocity in 0.1 encoder counts / second

5.4.3.290 `const Error * WaitEvent (Event & e, Timeout timeout = -1)`

Wait for an amplifier event condition.

This function can be used to wait on any generic event associated with the amplifier.

Parameters

<i>e</i>	The event to wait on.
<i>timeout</i>	The timeout for the wait (milliseconds). If < 0, then wait forever (default).

Returns

A pointer to an error object, or NULL on success.

5.4.3.291 `const Error * WaitEvent (Event & e, Timeout timeout, AMP_EVENT & match)`

Wait for an amplifier event condition.

This function can be used to wait on any generic event associated with the amplifier.

Parameters

<i>e</i>	The event to wait on.
<i>timeout</i>	The timeout for the wait (milliseconds). If < 0, then wait forever.
<i>match</i>	Returns the matching event condition.

Returns

A pointer to an error object, or NULL on success.

5.4.3.292 `const Error * WaitHomeDone (Timeout timeout = -1)`

Wait for the currently running homing move to finish, or for an error to occur.

This is similar to the [Amp::WaitMoveDone](#) method, except it does some additional checks after the move finishes to ensure that the homing operation was successful. This function will fail immediately if the amp is not currently in homing mode.

Parameters

<i>timeout</i>	The maximum time to wait (milliseconds)
----------------	---

Returns

A pointer to an error object, or NULL on success.

5.4.3.293 `const Error * WaitInputEvent (Event & e, Timeout timeout, uint32 & match)`

Wait on the amplifier's general purpose input pins.

The amplifier object maintains an [EventMap](#) object which reflects the state of the amplifier's general purpose input pins. Each bit of this [EventMap](#) corresponds to one input pin; bit 0 for input 0, bit 1 for input 1, etc. The bit in the event map is set when the corresponding input pin is high, and cleared when the input pin is low.

This function provides a very flexible method for waiting on a particular state on the input pins. [Event](#) objects may be created to define a specific state of one or more pins, and these objects may be used in conjunction with this function to wait for that state to occur.

In addition to this function, two simpler functions are also provided. These functions ([WaitInputHigh](#) and [WaitInputLow](#)) allow the user to wait on one or more input pins to go high or low respectively. Internally, these function call [WaitInputEvent](#) for their implementation.

Parameters

<i>e</i>	An Event object describing the input pin state to wait on.
<i>timeout</i>	The timeout for the wait (milliseconds). If < 0, then wait forever.
<i>match</i>	On success, the state of the input pins which caused the match to occur will be returned here.

Returns

A pointer to an error object, or NULL on success.

5.4.3.294 `const Error * WaitInputHigh (uint32 inputs, Timeout timeout = -1)`

Wait for any of the specified general purpose input pins to be set.

The inputs parameter specifies which input(s) to wait on using a bit mask. Bit 0 should be set for input 0, bit 1 for input 1, etc. The function will return when any of the specified input pins goes high.

Parameters

<i>inputs</i>	Specifies which input pin(s) to wait on.
<i>timeout</i>	The timeout for the wait (milliseconds). If < 0, then wait forever. If not specified, the timeout defaults to -1

Returns

A pointer to an error object, or NULL on success.

5.4.3.295 `const Error * WaitInputLow (uint32 inputs, Timeout timeout = -1)`

Wait for any of the specified general purpose input pins to be lowered.

The inputs parameter specifies which input(s) to wait on using a bit mask. Bit 0 should be set for input 0, bit 1 for input 1, etc. The function will return when any of the specified input pins goes low.

Parameters

<i>inputs</i>	Specifies which input pin(s) to wait on.
<i>timeout</i>	The timeout for the wait (milliseconds). If < 0, then wait forever. If not specified, the timeout defaults to -1

Returns

A pointer to an error object, or NULL on success.

5.4.3.296 `const Error * WaitMoveDone (Timeout timeout = -1)`

Wait for the currently running move to finish, or for an error to occur.

Parameters

<i>timeout</i>	The maximum time to wait (milliseconds)
----------------	---

Returns

A pointer to an error object, or NULL on success.

The documentation for this class was generated from the following files:

- [CML_Amp.h](#)
- [Amp.cpp](#)
- [AmpFile.cpp](#)
- [AmpParam.cpp](#)
- [AmpPDO.cpp](#)
- [AmpPVT.cpp](#)
- [AmpStruct.cpp](#)
- [AmpUnits.cpp](#)
- [AmpVersion.cpp](#)

5.5 AmpConfig Struct Reference

Amplifier configuration structure.

Collaboration diagram for AmpConfig:

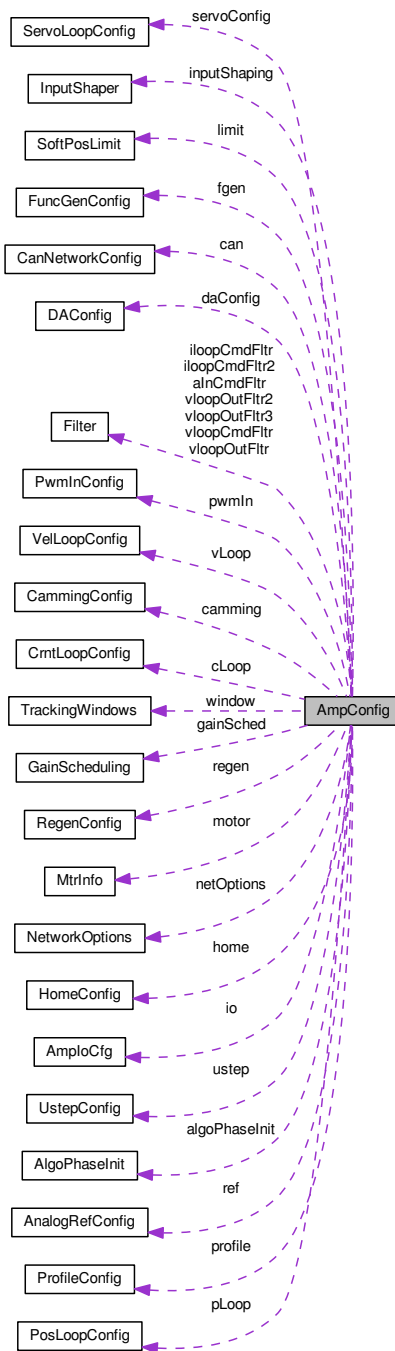

Public Member Functions

- [AmpConfig](#) ()

Default constructor. Simply sets all members to zero.

Public Attributes

- char [name](#) [COPLY_MAX_STRING]
Amplifier axis name.
- [AMP_MODE](#) [controlMode](#)
Amplifier default mode of operation.
- [AMP_PHASE_MODE](#) [phaseMode](#)
Amplifier phasing mode.
- [AMP_PWM_MODE](#) [pwmMode](#)
PWM output mode.
- char [CME_Config](#) [COPLY_MAX_STRING]
String used by CME to save state information This string is reserved and should not be modified.
- [AMP_FAULT](#) [faultMask](#)
Amplifier fault mask register.
- [uunit](#) [progVel](#)
Programmed velocity value.
- [int16](#) [progCrnt](#)
Programmed current value (0.01 amp units).
- [uint32](#) [options](#)
Amplifier options.
- [int16](#) [stepRate](#)
Diagnostic microstepping rate.
- [uint16](#) [capCtrl](#)
Index capture configuration.
- [EVENT_STATUS](#) [limitBitMask](#)
One bit of a standard CANopen status word is user programmable using this setting.
- [uint16](#) [encoderOutCfg](#)
Some amplifier models provide a secondary encoder connected which can be configured as either an input or output.
- [CanNetworkConfig](#) [can](#)
CANopen network configuration.
- [PosLoopConfig](#) [pLoop](#)
Position loop configuration.
- [VelLoopConfig](#) [vLoop](#)
Velocity loop configuration.
- [CrntLoopConfig](#) [cLoop](#)
Current loop configuration.
- [MtrlInfo](#) [motor](#)
Motor information.
- [TrackingWindows](#) [window](#)
Tracking window settings.
- [SoftPosLimit](#) [limit](#)
Software position limits.
- [AmpIoCfg](#) [io](#)
General purpose I/O pin configuration.
- [HomeConfig](#) [home](#)

- Homing mode configuration.*
- [ProfileConfig profile](#)
 - Trajectory profile settings.*
- [AnalogRefConfig ref](#)
 - Analog reference input settings.*
- [PwmInConfig pwmIn](#)
 - PWM input configuration.*
- [FuncGenConfig fgen](#)
 - Internal function generator settings.*
- [RegenConfig regen](#)
 - Regeneration resistor configuration.*
- [Filter vloopOutFtr](#)
 - Velocity loop output filter settings.*
- [Filter vloopCmdFtr](#)
 - Velocity loop command filter settings.*
- [Filter alnCmdFtr](#)
 - Analog command filter settings.*
- [InputShaper inputShaping](#)
 - Input shaping filter.*
- [UstepConfig ustep](#)
 - Stepper configuration.*
- [AlgoPhaseInit algoPhaseInit](#)
 - Algorithmic Phase Initialization.*
- [CammingConfig camming](#)
 - Camming Configuration.*
- [GainScheduling gainSched](#)
 - Gain Scheduling Configuration.*
- [NetworkOptions netOptions](#)
 - Can Bus network support.*
- [DAConfig daConfig](#)
 - D/A converter configuration.*
- [ServoLoopConfig servoConfig](#)
 - Configure various parts of the amps servo loops.*

5.5.1 Detailed Description

Amplifier configuration structure.

This structure contains all user configurable parameters used by an amplifier which may be stored in non-volatile memory.

5.5.2 Member Data Documentation

5.5.2.1 uint16 capCtrl

Index capture configuration.

This parameter is not normally used in CANopen mode and is included here for completeness only.

5.5.2.2 char CME_Config[COPLEY_MAX_STRING]

String used by CME to save state information This string is reserved and should not be modified.

5.5.2.3 uint16 encoderOutCfg

Some amplifier models provide a secondary encoder connected which can be configured as either an input or output. This parameter is used to configure this hardware.

5.5.2.4 EVENT_STATUS limitBitMask

One bit of a standard CANopen status word is user programmable using this setting. This feature is not used by CML and is only included here for completeness.

5.5.2.5 uint32 options

Amplifier options.
This parameter is reserved for future use.

5.5.2.6 AMP_PHASE_MODE phaseMode

Amplifier phasing mode.
This parameter controls the type of commutation used by the amplifier.

5.5.2.7 int16 progCrnt

Programmed current value (0.01 amp units).
This parameter is only used in [Amp](#) mode AMPMODE_PROG_CRNT.

5.5.2.8 uint progVel

Programmed velocity value.
This parameter is only used in [Amp](#) mode AMPMODE_PROG_VEL.

5.5.2.9 AMP_PWM_MODE pwmMode

PWM output mode.
This parameter can be used to configure the pwm output section of the amplifier.

5.5.2.10 int16 stepRate

Diagnostic microstepping rate.
This parameter gives the microstep rate (degrees / second) for use in a special diagnostic microstepping mode. The parameter is not used in normal CANopen modes, and is only include here for completeness.

The documentation for this struct was generated from the following file:

- [CML_AmpStruct.h](#)

5.6 AmpError Class Reference

This class represents error conditions that can occur in the Copley Amplifier object.

Inheritance diagram for AmpError:

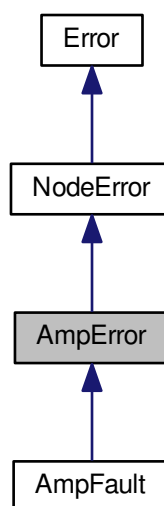

Collaboration diagram for AmpError:

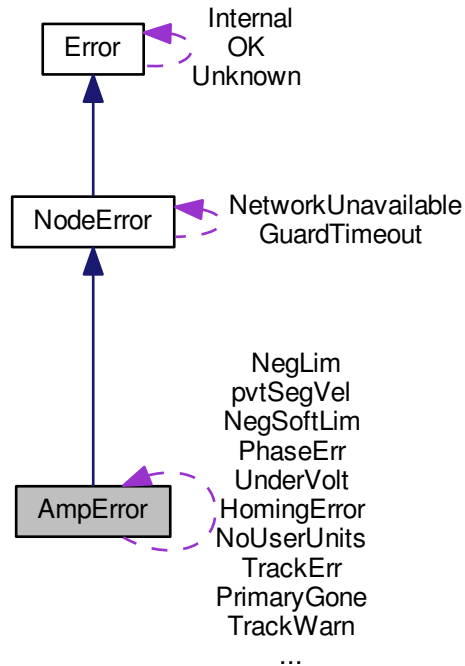

Static Public Member Functions

- static const [AmpError](#) * [DecodeStatus](#) ([EVENT_STATUS](#) stat)
Decode the passed event status word and return an appropriate error object.

Static Public Attributes

- static const [AmpError](#) [Fault](#)
Latching fault is active.
- static const [AmpError](#) [ShortCircuit](#)
Short circuit detected.
- static const [AmpError](#) [AmpTemp](#)
Amplifier over temp.
- static const [AmpError](#) [OverVolt](#)
Amplifier over voltage.
- static const [AmpError](#) [UnderVolt](#)
Amplifier under voltage.
- static const [AmpError](#) [MotorTemp](#)
Motor over temp.

- static const [AmpError EncoderPower](#)
Encoder power error.
- static const [AmpError PhaseErr](#)
Motor phasing error.
- static const [AmpError TrackErr](#)
Position tracking error.
- static const [AmpError NodeState](#)
The drive's state is inappropriate for the requested operation.
- static const [AmpError pvtSegPos](#)
PVT segment position value over 24-bits.
- static const [AmpError pvtSegVel](#)
PVT segment velocity value too large.
- static const [AmpError pvtBufferFull](#)
PVT trajectory buffer full.
- static const [AmpError badDeviceID](#)
Unknown device identity.
- static const [AmpError badHomeParam](#)
Bad parameter specified to home command.
- static const [AmpError badMoveParam](#)
Bad parameter specified to move command.
- static const [AmpError InMotion](#)
Amplifier is currently in motion.
- static const [AmpError GuardError](#)
The amplifier's heartbeat message timed out.
- static const [AmpError PosLim](#)
Positive limit switch is active.
- static const [AmpError NegLim](#)
Negative limit switch is active.
- static const [AmpError PosSoftLim](#)
Positive software limit is active.
- static const [AmpError NegSoftLim](#)
Negative software limit is active.
- static const [AmpError TrackWarn](#)
Position tracking warning.
- static const [AmpError Unknown](#)
An error occurred, but went away before it could be decoded.
- static const [AmpError Reset](#)
The amplifier has been reset.
- static const [AmpError Disabled](#)
The amplifier is disabled.
- static const [AmpError QuickStopMode](#)
The amplifier is doing a quick stop.
- static const [AmpError NoUserUnits](#)
User units are not available (see [CML_Settings.h](#))
- static const [AmpError Abort](#)
Last trajectory aborted.
- static const [AmpError pvtPosUnavail](#)

The PVT segment position is not available.

- static const [AmpError VelWin](#)

Velocity tracking window exceeded.

- static const [AmpError PhaseInit](#)

Amplifier is currently performing a phase initialization.

- static const [AmpError NotHoming](#)

The amplifier is not currently configured for homing mode.

- static const [AmpError HomingError](#)

The amplifier did not complete the homing method successfully.

- static const [AmpError BadAxis](#)

Illegal axis number specified.

- static const [AmpError PrimaryGone](#)

Primary axis [Amp](#) object no longer available.

- static const [AmpError NotInit](#)

[Amp](#) object not properly initialized.

Protected Member Functions

- [AmpError](#) (uint16 id, const char *desc)

Standard protected constructor.

Additional Inherited Members

5.6.1 Detailed Description

This class represents error conditions that can occur in the Copley Amplifier object.

5.6.2 Member Function Documentation

5.6.2.1 const [AmpError](#) * DecodeStatus ([EVENT_STATUS](#) *stat*) [static]

Decode the passed event status word and return an appropriate error object.

Parameters

<i>stat</i>	The amplifier event status register
-------------	-------------------------------------

Returns

A pointer to an error object, or NULL if there is no error.

The documentation for this class was generated from the following files:

- [CML_Amp.h](#)
- [Amp.cpp](#)

5.7 AmpFault Class Reference

This class represents latching amplifier fault conditions.

Inheritance diagram for AmpFault:

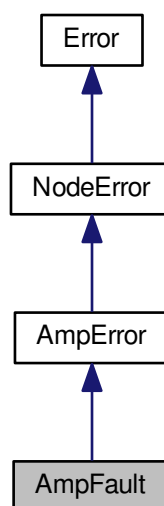

Collaboration diagram for AmpFault:

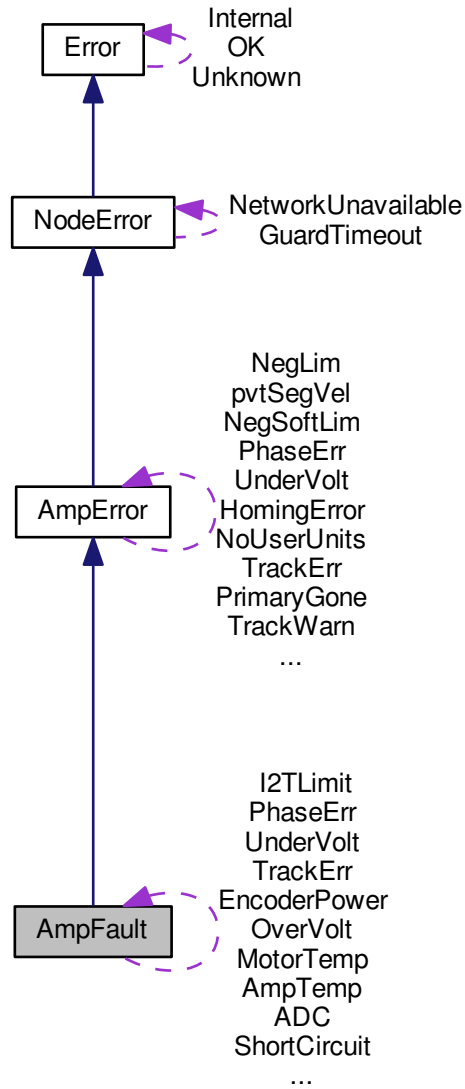

Static Public Member Functions

- static const [AmpFault](#) * [DecodeFault](#) ([AMP_FAULT](#) f)
Return an appropriate fault object based on the amplifier fault mask.

Static Public Attributes

- static const [AmpFault](#) [Memory](#)

- Fatal hardware error: the flash data is corrupt.*

 - static const [AmpFault ADC](#)
- Fatal hardware error: An A/D offset error has occurred.*

 - static const [AmpFault ShortCircuit](#)
- The amplifier detected a short circuit condition.*

 - static const [AmpFault AmpTemp](#)
- The amplifier is over temperature.*

 - static const [AmpFault MotorTemp](#)
- A motor temperature error was detected.*

 - static const [AmpFault OverVolt](#)
- The amplifier bus voltage is over the acceptable limit.*

 - static const [AmpFault UnderVolt](#)
- The amplifier bus voltage is below the acceptable limit.*

 - static const [AmpFault EncoderPower](#)
- Over current on the encoder power supply.*

 - static const [AmpFault PhaseErr](#)
- Amplifier phasing error.*

 - static const [AmpFault TrackErr](#)
- Tracking error, the position error is too large.*

 - static const [AmpFault I2TLimit](#)
- Current limited by I^2 algorithm.*

 - static const [AmpFault Unknown](#)
- Some unknown amplifier fault has occurred.*

Protected Member Functions

- [AmpFault](#) (uint16 id, const char *desc)
- Standard protected constructor.*

Additional Inherited Members

5.7.1 Detailed Description

This class represents latching amplifier fault conditions.

5.7.2 Member Function Documentation

5.7.2.1 const [AmpFault](#) * DecodeFault ([AMP_FAULT](#) fault) [static]

Return an appropriate fault object based on the amplifier fault mask.

Parameters

<i>fault</i>	The amplifier fault mask.
--------------	---------------------------

Returns

A pointer to the fault object, NULL if there is no fault.

The documentation for this class was generated from the following files:

- [CML_Amp.h](#)
- [Amp.cpp](#)

5.8 AmpFileError Class Reference

This class represents error conditions that can occur when loading amplifier data from a data file.

Inheritance diagram for AmpFileError:

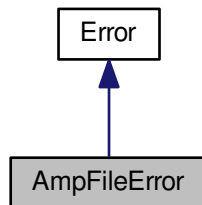

Collaboration diagram for AmpFileError:

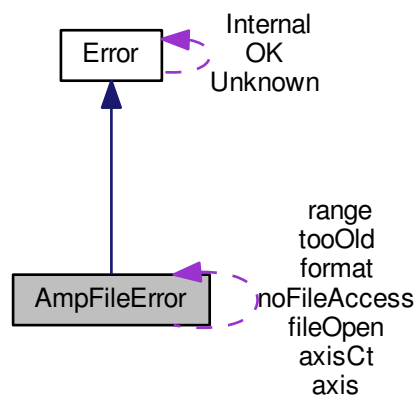

Static Public Attributes

- static const [AmpFileError format](#)
Amplifier file format error.
- static const [AmpFileError tooOld](#)
Amplifier file format is too old, use CME version 3.1 or later.
- static const [AmpFileError noFileAccess](#)
File access was not enabled at compile time. See [CML_Settings.h](#).
- static const [AmpFileError fileOpen](#)
Error opening amplifier file.
- static const [AmpFileError range](#)
A parameter in the amplifier file is out of range.
- static const [AmpFileError axis](#)
Amplifier file is for multi axis, not supported.
- static const [AmpFileError axisCt](#)
Amplifier requested an axis that is not present in the ccx file or vice versa.

Protected Member Functions

- [AmpFileError](#) (uint16 id, const char *desc)
Standard protected constructor.

Additional Inherited Members

5.8.1 Detailed Description

This class represents error conditions that can occur when loading amplifier data from a data file.

The documentation for this class was generated from the following file:

- [CML_AmpStruct.h](#)

5.9 AmpInfo Struct Reference

Amplifier characteristics data structure.

Public Attributes

- char [model](#) [COPLY_MAX_STRING]
Model number string.
- char [mfgName](#) [COPLY_MAX_STRING]
Name of the amplifier manufacturer.
- char [mfgWeb](#) [COPLY_MAX_STRING]
Web address of the manufacturer.
- char [mfgInfo](#) [COPLY_MAX_STRING]
Amplifier's manufacturing information string.
- char [swVer](#) [COPLY_MAX_STRING]

- *Software version number.*
- [uint16 swVerNum](#)
Version number represented as an integer.
- [uint32 serial](#)
Serial number.
- [uint32 modes](#)
Supported modes of operation (see DSP402 spec)
- [uint16 crntPeak](#)
Peak current rating (10 milliamp units)
- [uint16 crntCont](#)
Continuous current rating (10 milliamp units)
- [uint16 crntTime](#)
Time at peak current (milliseconds)
- [uint16 voltMax](#)
Max bus voltage (100 millivolt units)
- [uint16 voltMin](#)
Min bus voltage (100 millivolt units)
- [uint16 voltHyst](#)
Bus voltage hysteresis for over voltage shutdown (100 millivolt units)
- [uint16 tempMax](#)
Max temperature (deg C)
- [uint16 tempHyst](#)
Temperature hysteresis for over temp shutdown (deg C)
- [uint16 pwmPeriod](#)
PWM period (10 nanosecond units)
- [uint16 servoPeriod](#)
Servo period (multiples of PWM period)
- [int16 crntScale](#)
Current scaling factor.
- [int16 voltScale](#)
Voltage scaling factor.
- [int16 refScale](#)
Reference scaling factor.
- [int16 aencScale](#)
Analog encoder scaling factor.
- [int16 type](#)
Amp type.
- [int16 pwm_off](#)
PWM off time.
- [int16 pwm_dbzero](#)
PWM deadband @ zero current.
- [int16 pwm_dbcont](#)
PWM deadband @ continuous current.
- [int16 regenPeak](#)
Internal regen resister peak limit.
- [int16 regenCont](#)
Internal regen resister continuous limit.
- [int16 regenTime](#)
Internal regen resister peak time.

5.9.1 Detailed Description

Amplifier characteristics data structure.

This structure is used to hold information about the amplifier such as it's model number, serial number, peak current rating, etc.

The amplifier characteristics defined in this structure can not be changed. They are defined by Copley Controls when the amplifier is designed and/or manufactured.

Use the [Amp::GetAmpInfo](#) method to retrieve this information from the amplifier.

The documentation for this struct was generated from the following file:

- [CML_AmpStruct.h](#)

5.10 AmploCfg Struct Reference

Programmable I/O pin configuration.

Public Member Functions

- [AmploCfg](#) (void)
Default constructor for [AmploCfg](#) structure.

Public Attributes

- [uint8 inputCt](#)
Number of programmable inputs available on this amplifier.
- [uint8 outputCt](#)
Number of programmable outputs available on this amplifier.
- [uint16 inPullUpCfg](#)
Input pin pull-up / pull-down resister configuration.
- [int32 inPullUpCfg32](#)
Input pin pull-up / pull-down resister configuration.
- [INPUT_PIN_CONFIG inCfg](#) [COPLEY_MAX_INPUTS]
Input pin configuration for each pin.
- [int16 inDebounce](#) [COPLEY_MAX_INPUTS]
Input pin debounce time (milliseconds)
- [OUTPUT_PIN_CONFIG outCfg](#) [COPLEY_MAX_OUTPUTS]
Output pin configuration for each output pin See [Amp::SetOutputConfig](#) for more information.
- [uint32 outMask](#) [COPLEY_MAX_OUTPUTS]
Output pin configuration mask for each pin.
- [uint32 outMask1](#) [COPLEY_MAX_OUTPUTS]
Output pin configuration mask for each pin.
- [int32 ioOptions](#)
IO Options, used to configure the optional features of the general purpose IO.

5.10.1 Detailed Description

Programmable I/O pin configuration.

5.10.2 Constructor & Destructor Documentation

5.10.2.1 AmploCfg (void)

Default constructor for [AmploCfg](#) structure.

This simply sets all member parameters to default values of zero.

5.10.3 Member Data Documentation

5.10.3.1 INPUT_PIN_CONFIG inCfg[COPLEY_MAX_INPUTS]

Input pin configuration for each pin.

See [Amp::SetInputConfig](#) for more information.

5.10.3.2 uint16 inPullUpCfg

Input pin pull-up / pull-down resister configuration.

See [Amp::SetIoPullup](#) for more information

5.10.3.3 int32 inPullUpCfg32

Input pin pull-up / pull-down resister configuration.

32 Bit version of paramter inPullUpCfg

5.10.3.4 uint8 inputCt

Number of programmable inputs available on this amplifier.

This is a read only parameter, writes have no effect.

5.10.3.5 uint32 outMask[COPLEY_MAX_OUTPUTS]

Output pin configuration mask for each pin.

See [Amp::SetOutputConfig](#) for more information

5.10.3.6 uint32 outMask1[COPLEY_MAX_OUTPUTS]

Output pin configuration mask for each pin.

See [Amp::SetOutputConfig](#) for more information

5.10.3.7 uint8 outputCt

Number of programmable outputs available on this amplifier.

This is a read only parameter, writes have no effect.

The documentation for this struct was generated from the following files:

- [CML_AmpStruct.h](#)
- [AmpStruct.cpp](#)

5.11 AmpSettings Class Reference

Copley amplifier settings object.

Public Member Functions

- [AmpSettings \(\)](#)
Create a settings object with all default values.

Public Attributes

- [uint32 synchPeriod](#)
Synch object period in microseconds.
- [uint32 synchID](#)
Synch object CAN message ID.
- [bool synchUseFirstAmp](#)
Use first initialized amplifier as synch producer.
- [bool synchProducer](#)
Synch producer (true/false) If true, this node will produce synch messages.
- [uint32 timeStampID](#)
High resolution time stamp CAN ID.
- [uint16 heartbeatPeriod](#)
The CANopen heartbeat protocol is one of two standard methods used to constantly watch for network or device problems.
- [uint16 heartbeatTimeout](#)
Additional time to wait before generating a heartbeat error (milliseconds) If the heartbeat protocol is used, then this value, combined with the heartbeatTime will determine how long the network master waits for the node's heartbeat message before it generates a heartbeat error.
- [uint16 guardTime](#)
Node guarding guard time (milliseconds)
- [uint8 lifeFactor](#)
Node guarding life time factor.
- [bool enableOnInit](#)
Enable amplifier at init time.
- [AMP_MODE initialMode](#)
Initial mode of operation.
- [bool resetOnInit](#)
Reset the amplifier on init.
- [uint8 maxPvtSendCt](#)
Max PVT segments to send in response to a PVT status update.

5.11.1 Detailed Description

Copley amplifier settings object.

This object is passed to the Init() method of the Copley amp. It holds the various customizable settings used by the amplifier.

5.11.2 Constructor & Destructor Documentation

5.11.2.1 AmpSettings (void)

Create a settings object with all default values.

Default constructor for amplifier settings object.

The default values for each member of this class are defined below.

This constructor sets all the settings to the default values.

5.11.3 Member Data Documentation

5.11.3.1 bool enableOnInit

Enable amplifier at init time.

If this is true, then the amplifier will be enabled at the end of a successful init(). If false, the amplifier will be disabled when init() returns.

Default: true

5.11.3.2 uint16 guardTime

[Node](#) guarding guard time (milliseconds)

The CANopen node guarding protocol is a second method (the first being the heartbeat protocol) for devices on the network to watch for network problems. In this protocol, the master controller sends a request message out to the slave device at a specified interval. The slave device responds to this request with a message indicating its state.

The main difference between this protocol and the heartbeat protocol is that both the slave node and the master are able to recognize network errors. With the heartbeat protocol only the network master is able to identify network problems.

Note that only one of these two protocols can be active in a node device at any time. If the heartbeat period is non-zero, then the heartbeat protocol will be used.

This parameter gives the node guarding period for use with this node. This is the period between node guarding request messages sent by the master controller.

Note that both this parameter, and the life time factor must be non-zero for node guarding to be used.

For [EtherCAT](#) networks, this parameter specifies the process data heartbeat timeout. This is similar to the CANopen node guarding timeout. If the drive is operational, and goes this long without receiving process data from the master, then it will identify a timeout condition.

Default 200 (ms)

5.11.3.3 uint16 heartbeatPeriod

The CANopen heartbeat protocol is one of two standard methods used to constantly watch for network or device problems.

When the heartbeat protocol is used, each device on the CANopen network transmits a 'heartbeat' message at a specified interval. The network master watches for these messages, and is able to detect a device error if its heartbeat message is not received within the expected time.

This parameter configures the heartbeat period (milliseconds) that will be used by this amplifier to transmit its heartbeat message.

If this parameter is set to zero, then the heartbeat protocol is disabled on this node.

This setting is not used on [EtherCAT](#) networks.

Default: zero (not used)

5.11.3.4 uint16 heartbeatTimeout

Additional time to wait before generating a heartbeat error (milliseconds) If the heartbeat protocol is used, then this value, combined with the heartbeatTime will determine how long the network master waits for the node's heartbeat message before it generates a heartbeat error.

Note that setting this to zero does not disable the heartbeat protocol. set the heartbeatPeriod value to zero to disable heartbeat.

This setting is not used on [EtherCAT](#) networks.

Default 200 (ms)

5.11.3.5 AMP_MODE initialMode

Initial mode of operation.

This defines the mode of operation that the amplifier will be placed in when it is initialized.

Default: AMPMODE_CAN_HOMING

5.11.3.6 uint8 lifeFactor

[Node](#) guarding life time factor.

When the node guarding protocol is used, this parameter is used by the slave device to determine how long to wait for a node guarding request from the master controller before signaling an error condition.

The life time factor is treated as a multiple of the guard time.

If this parameter and the node guard time are both non-zero, and the heartbeatTime is zero, then node guarding will be setup for the amplifier.

This setting is not used on [EtherCAT](#) networks.

Default 3 (multiples of the guard time)

5.11.3.7 uint8 maxPvtSendCt

Max PVT segments to send in response to a PVT status update.

This parameter may be used to limit the number of new PVT segments to send in response to a PVT status update. Normally, this parameter may be safely left at its default setting.

Default 6

5.11.3.8 bool resetOnInit

Reset the amplifier on init.

If true, the amplifier will be reset when it is initialized.

Note that resetting nodes on an [EtherCAT](#) network will make it impossible to access anything on the network while the reset is occurring. Resetting [EtherCAT](#) nodes is therefore not recommended.

Default: false

5.11.3.9 uint32 synchID

Synch object CAN message ID.

This is the message ID used for the synch message. Default is 0x00000080

5.11.3.10 uint32 synchPeriod

Synch object period in microseconds.

The synch object is a message that is transmitted by one node on a CANopen network at a fixed interval. This message is used to synchronize the devices on the network.

Default is 10,000 (10 ms).

5.11.3.11 bool synchProducer

Synch producer (true/false) If true, this node will produce synch messages.

Default: false

Note: If the 'synchUseFirstAmp' setting of this object is true, then the passed value of this settings will not be used, and will be overwritten during initialization.

Note: There should be exactly one synch producer on every network.

5.11.3.12 bool synchUseFirstAmp

Use first initialized amplifier as synch producer.

If this setting is true (default), then the first amplifier to be initialized will be set as the synch producer, and all other amplifier's will be setup as synch consumers. This causes the value of the 'synchProducer' setting to be updated during init to indicate whether the amp is producing synch messages or not.

By default, this setting is true

5.11.3.13 uint32 timeStampID

High resolution time stamp CAN ID.

The high resolution time stamp is a [PDO](#) that is generated by the synch producer and consumed by the other amplifiers on the network. It is used to synchronize the clocks of the amplifiers. This parameter defines the CAN ID that will be used for this message. Setting to zero will disable the time stamp message. Default 0x0180

The documentation for this class was generated from the following files:

- [CML_Amp.h](#)
- [Amp.cpp](#)

5.12 AnalogRefConfig Struct Reference

Analog input configuration.

Public Member Functions

- [AnalogRefConfig](#) (void)
Default constructor. Simply sets all members to zero.

Public Attributes

- [int16 calibration](#)
Calibration offset.
- [int16 offset](#)
Offset in millivolts.
- [int16 deadband](#)
Deadband in millivolts.
- [int32 scale](#)
Scaling factor.

5.12.1 Detailed Description

Analog input configuration.

These parameters are used when the amplifier is being driven from its analog reference input pin. Note that not all amplifiers have an analog input reference, and that this is not a standard CANopen mode of operation.

5.12.2 Member Data Documentation

5.12.2.1 int16 calibration

Calibration offset.

This offset is set at the factory and should normally not be modified. Units are millivolts

5.12.2.2 int16 deadband

Deadband in millivolts.

The analog input will be treated as zero when its absolute value is less than this.

5.12.2.3 int32 scale

Scaling factor.

Units are dependent on the mode of operation: 0.01 Amp when driving current. 0.1 Encoder counts/second when driving velocity

The documentation for this struct was generated from the following file:

- [CML_AmpStruct.h](#)

5.13 APRD Struct Reference

Read by position in network (aka Auto Increment Physical Read) The read is performed on the node who's position matches the passed address.

Inheritance diagram for APRD:

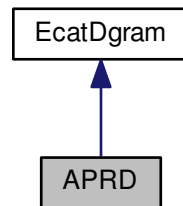

Collaboration diagram for APRD:

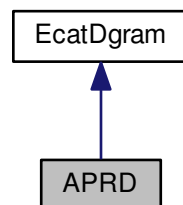

Additional Inherited Members

5.13.1 Detailed Description

Read by position in network (aka Auto Increment Physical Read) The read is performed on the node who's position matches the passed address.

Pass 0 for the node closest to the master, 1 for the next node, etc. In the datagram sent out, the ADP field will hold -N for a passed address of N. Each node increments the ADP value as it passes, and the node that receives a zero responds to the read.

The documentation for this struct was generated from the following file:

- [CML_EtherCAT.h](#)

5.14 APWR Struct Reference

Write by position in network (Auto Increment Physical Write) Like the [APRD](#) datagram, but a write version.

Inheritance diagram for APWR:

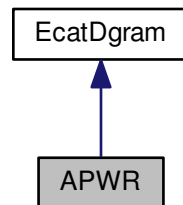

Collaboration diagram for APWR:

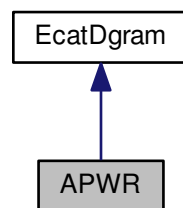

Additional Inherited Members

5.14.1 Detailed Description

Write by position in network (Auto Increment Physical Write) Like the [APRD](#) datagram, but a write version.

The documentation for this struct was generated from the following file:

- [CML_EtherCAT.h](#)

5.15 ARMW Struct Reference

Read by position in network and write to the same address of all following nodes.

Inheritance diagram for ARMW:

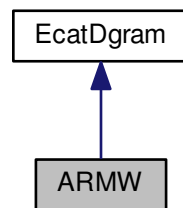

Collaboration diagram for ARMW:

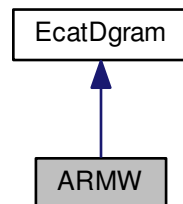

Additional Inherited Members

5.15.1 Detailed Description

Read by position in network and write to the same address of all following nodes.

The read is performed on the node who's position matches the passed address. Pass 0 for the node closest to the master, 1 for the next node, etc. All nodes after that position will have the data read from the earlier node written to the same address

The documentation for this struct was generated from the following file:

- [CML_EtherCAT.h](#)

5.16 Array< C > Class Template Reference

This class template implements a simple dynamic array of a given type.

Inheritance diagram for Array< C >:

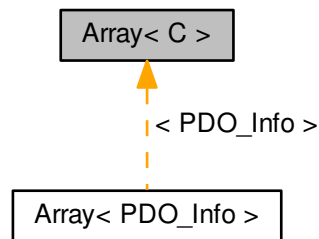

Public Member Functions

- [Array](#) (int init=32, int step=-1)
Default constructor for a dynamic array.
- virtual [~Array](#) ()
Default destructor.
- int [length](#) (void)
Returns the current number of elements currently stored in the [Array](#).
- C & [operator\[\]](#) (int ndx)
Return a reference to the item at the specified index.
- void [add](#) (C val)
Append a value to the end of the array.
- void [rem](#) (int ndx)
Remove the element at the specified index.

5.16.1 Detailed Description

```
template<class C>class Array< C >
```

This class template implements a simple dynamic array of a given type.

5.16.2 Constructor & Destructor Documentation

5.16.2.1 `Array (int init = 32, int step = -1) [inline]`

Default constructor for a dynamic array.

Parameters

<i>init</i>	Number of objects to initially allocate space for
<i>step</i>	When new data is needed, the array size will be increased by this amount. If this parameter is negative (default), then the initial value will be used. If this parameter is zero, then the array size will be doubled on each increase.

5.16.3 Member Function Documentation

5.16.3.1 `void add (C val) [inline]`

Append a value to the end of the array.

The array will grow to accommodate the new data if necessary.

Parameters

<i>val</i>	Value to append.
------------	------------------

5.16.3.2 `int length (void) [inline]`

Returns the current number of elements currently stored in the [Array](#).

Returns

Number of stored elements

5.16.3.3 `C& operator[] (int ndx) [inline]`

Return a reference to the item at the specified index.

Parameters

<i>ndx</i>	Index of the element to return
------------	--------------------------------

Returns

Reference to the data at the specified index.

5.16.3.4 `void rem (int ndx) [inline]`

Remove the element at the specified index.

The array will be compacted.

Parameters

<i>ndx</i>	The index of the value to remove
------------	----------------------------------

The documentation for this class was generated from the following file:

- [CML_Array.h](#)

5.17 BRD Struct Reference

Broadcast read.

Inheritance diagram for BRD:

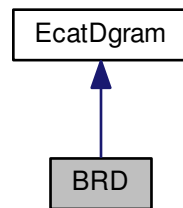

Collaboration diagram for BRD:

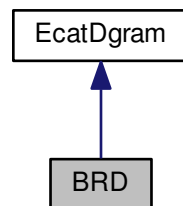

Additional Inherited Members

5.17.1 Detailed Description

Broadcast read.

This type of datagram reads data from the same location on every node in the network. Returned data is ORed, so any bit set in any node will be set in the accumulated response. The ADP address is sent out from the master as zero and incremented by every slave that responds to the read.

The documentation for this struct was generated from the following file:

- [CML_EtherCAT.h](#)

5.18 BWR Struct Reference

Broadcast write. This type of datagram writes data to the same location on every node in the network.

Inheritance diagram for BWR:

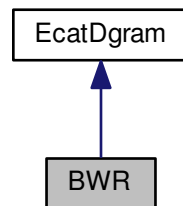

Collaboration diagram for BWR:

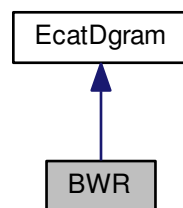

Additional Inherited Members

5.18.1 Detailed Description

Broadcast write. This type of datagram writes data to the same location on every node in the network.

The documentation for this struct was generated from the following file:

- [CML_EtherCAT.h](#)

5.19 CammingConfig Struct Reference

Configuration structure used to set up the camming.

Public Member Functions

- [CammingConfig](#) (void)
Default constructor.

Public Attributes

- [uint16 cammingModeConfig](#)
Camming Mode configuration. See documentation for details.
- [uint16 cammingDelayForward](#)
Camming delay forward.(Units:master command counts)
- [uint16 cammingDelayReverse](#)
Camming delay forward.(Units:master command counts)
- [int32 cammingMasterVel](#)
Camming master velocity.

5.19.1 Detailed Description

Configuration structure used to set up the camming.

These settings may be up/download from the amplifier using the functions [Amp::SetCammingConfig](#) and [Amp::GetCammingConfig](#).

5.19.2 Constructor & Destructor Documentation

5.19.2.1 `CammingConfig(void) [inline]`

Default constructor.

Initializes all structure elements to zero.

5.19.3 Member Data Documentation

5.19.3.1 `int32 cammingMasterVel`

Camming master velocity.

Constnat velocity of the Camming internal generator. (Units 0.1 counts/s)

The documentation for this struct was generated from the following file:

- [CML_AmpStruct.h](#)

5.20 CanError Class Reference

Class used to represent an error condition returned from a CAN interface function.

Inheritance diagram for CanError:

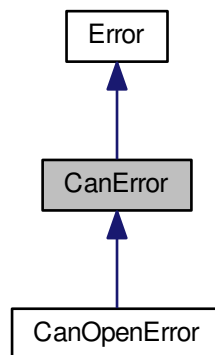

Collaboration diagram for CanError:

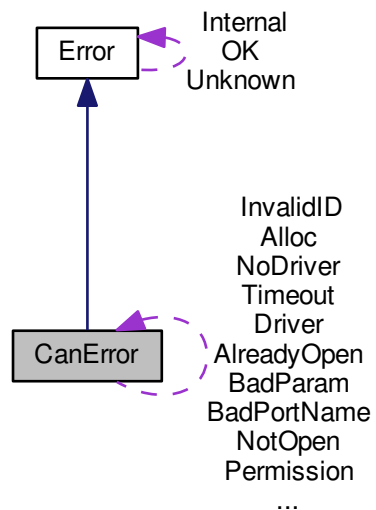

Static Public Attributes

- static const [CanError BadPortName](#)
Indicates that the specified port name is invalid.
- static const [CanError NotOpen](#)
Indicates that the CAN port is not open.
- static const [CanError AlreadyOpen](#)
Indicates an illegal attempt to open an already open port.
- static const [CanError BadParam](#)
A parameter passed to the CAN member function is not valid.
- static const [CanError Driver](#)
Generic error from the CAN driver.
- static const [CanError BadBaud](#)
Illegal baud rate specified.
- static const [CanError Timeout](#)
Timeout waiting on read/write.
- static const [CanError Overflow](#)
CAN buffer overflow.
- static const [CanError BusOff](#)
CAN bus is in the OFF state.
- static const [CanError InvalidID](#)
Indicates an invalid CAN ID passed.
- static const [CanError Unknown](#)
Unknown CAN error condition.
- static const [CanError NoDriver](#)
Unable to open CAN driver, or missing dll file.
- static const [CanError Alloc](#)
CAN driver memory allocation error.
- static const [CanError Permission](#)
Permission error opening CAN port.

Additional Inherited Members

5.20.1 Detailed Description

Class used to represent an error condition returned from a CAN interface function.

The documentation for this class was generated from the following file:

- [CML_Can.h](#)

5.21 CanFrame Struct Reference

Low level CAN data frame.

Public Attributes

- [CAN_FRAME_TYPE](#) type
Identifies the frame type.
- [int32](#) id
The CAN message ID.
- [uint32](#) timestamp
Timestamp of received frame if supported by CAN interface.
- [byte](#) length
Gives the number of bytes of data included in the frame.
- [byte](#) data [8]
Holds any data sent with the frame.

5.21.1 Detailed Description

Low level CAN data frame.

This class is used to represent the basic frame of information that is passed over the CAN network.

A frame of CAN data consists of a message ID value (either 11 or 29 bits depending on whether standard or extended frames are in use), 0 to 8 bytes of data, and some special attributes.

Frame objects are passed to the [CanInterface::Xmit\(\)](#) function, and filled in by the [CanInterface::Recv\(\)](#) function.

5.21.2 Member Data Documentation

5.21.2.1 [byte](#) data[8]

Holds any data sent with the frame.

A frame may be accompanied by 0 to 8 bytes of data.

5.21.2.2 [int32](#) id

The CAN message ID.

If bit 29 is clear, this is a standard 11 bit ID (bits 0-10 hold the ID). If bit 29 is set, this is an extended 29 bit ID (bits 0-28 hold the ID). Bits 30 and 31 are not presently used.

5.21.2.3 [byte](#) length

Gives the number of bytes of data included in the frame.

The length of a frame may range from 0 to 8 bytes

The documentation for this struct was generated from the following file:

- [CML_Can.h](#)

5.22 CanInterface Class Reference

Abstract class used for low level interaction with CAN hardware.

Inheritance diagram for CanInterface:

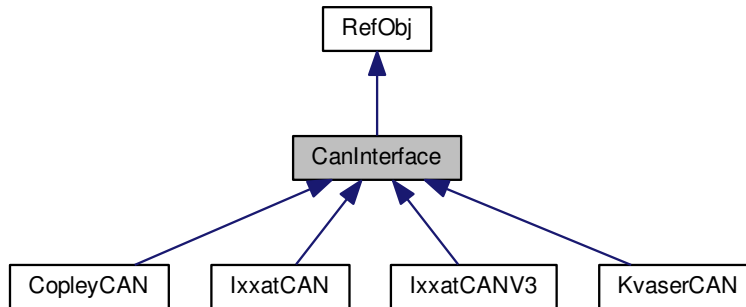

Collaboration diagram for CanInterface:

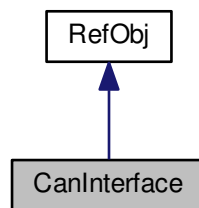

Public Member Functions

- [CanInterface](#) (void)
Default constructor for a CAN interface object.
- [CanInterface](#) (const char *port)
Standard constructor for the CAN interface object.
- virtual [~CanInterface](#) ()
Standard destructor for base [CanInterface](#) object.
- virtual const [Error](#) * [SetName](#) (const char *name)
Set the name of the port.
- virtual const [Error](#) * [Open](#) (void)

- *Open the CAN interface.*
- virtual const [Error](#) * [Close](#) (void)
 - *Close the CAN interface.*
- virtual const [Error](#) * [SetBaud](#) (int32 baud)
 - *Set the CAN interface baud rate.*
- const [Error](#) * [Recv](#) ([CanFrame](#) &frame, Timeout timeout=-1)
 - *Receive the next CAN frame.*
- const [Error](#) * [Xmit](#) ([CanFrame](#) &frame, Timeout timeout=0)
 - *Write a CAN frame to the CAN network.*
- virtual bool [SupportsTimestamps](#) (void)
 - *Return true if the CAN interface supports timestamps on received frames.*

Static Public Member Functions

- static const [Error](#) * [ChkID](#) (int32 id)
 - *Check an ID to make sure it's valid.*

Protected Member Functions

- virtual const [Error](#) * [RecvFrame](#) ([CanFrame](#) &frame, Timeout timeout)
 - *Receive the next CAN frame.*
- virtual const [Error](#) * [XmitFrame](#) ([CanFrame](#) &frame, Timeout timeout)
 - *Write a CAN frame to the CAN network.*

Protected Attributes

- char * [portName](#)
 - *This string is initialized by the default constructor.*

5.22.1 Detailed Description

Abstract class used for low level interaction with CAN hardware.

This class contains methods that are used to open and close the CAN network adapter, as well as transmit and receive frames over the CAN network.

The base [CanInterface](#) class defines a standard minimal interface to the CAN network. This base class does not actually provide support for any hardware, rather it should be extended by a class that provides access to the actual CAN network adapter being used.

5.22.2 Constructor & Destructor Documentation

5.22.2.1 [CanInterface](#) (const char * port) [inline]

Standard constructor for the CAN interface object.

The only thing that the constructor does is initialize the portName member variable to the value passed.

Parameters

<i>port</i>	A string that may be used to identify which port to open.
-------------	---

5.22.3 Member Function Documentation

5.22.3.1 static const Error* ChkID (int32 id) [inline],[static]

Check an ID to make sure it's valid.

To be valid, a message ID must either be an 11 bit standard ID, or a 28-bit extended ID. By convention, all extended ID's must have bit 29 set to identify them as such.

Parameters

<i>id</i>	The ID to be checked
-----------	----------------------

Returns

A pointer to an error object, or NULL on success.

5.22.3.2 virtual const Error* Close (void) [inline],[virtual]

Close the CAN interface.

Returns

A valid CAN error object

Reimplemented in [KvaserCAN](#), [lxxatCANV3](#), [lxxatCAN](#), and [CopleyCAN](#).

5.22.3.3 virtual const Error* Open (void) [inline],[virtual]

Open the CAN interface.

Returns

A valid CAN error object

Reimplemented in [KvaserCAN](#), [lxxatCANV3](#), [lxxatCAN](#), and [CopleyCAN](#).

5.22.3.4 const Error * Recv (CanFrame & frame, Timeout timeout = -1)

Receive the next CAN frame.

This is the public function used to read CAN messages from the network.

Parameters

<i>frame</i>	A reference to the frame object that will be filled by the read.
<i>timeout</i>	The timeout (ms) to wait for the frame. A timeout of 0 will return immediately if no data is available. A timeout of < 0 will wait forever.

Returns

A pointer to an error object, or NULL on success.

5.22.3.5 `const Error * RecvFrame (CanFrame & frame, Timeout timeout)` [protected],[virtual]

Receive the next CAN frame.

This is called by the public Recv function, and must be implemented by the actual CanInterface class. It handles the hardware specific details of reading a message from the network.

Parameters

<i>frame</i>	A reference to the frame object that will be filled by the read.
<i>timeout</i>	The timeout (ms) to wait for the frame. A timeout of 0 will return immediately if no data is available. A timeout of < 0 will wait forever.

Returns

A pointer to an error object, or NULL on success.

Reimplemented in [KvaserCAN](#), [IxxatCANV3](#), [IxxatCAN](#), and [CopleyCAN](#).

5.22.3.6 `virtual const Error* SetBaud (int32 baud)` [inline],[virtual]

Set the CAN interface baud rate.

Parameters

<i>baud</i>	In bits / second
-------------	------------------

Returns

A valid CAN error object

Reimplemented in [KvaserCAN](#), [IxxatCANV3](#), [IxxatCAN](#), and [CopleyCAN](#).

5.22.3.7 `const Error * SetName (const char * name)` [virtual]

Set the name of the port.

Parameters

<i>name</i>	The port name.
-------------	----------------

Returns

A pointer to an error object, or NULL on success.

5.22.3.8 `virtual bool SupportsTimestamps (void) [inline],[virtual]`

Return true if the CAN interface supports timestamps on received frames.

Returns

true if timestamps are supported

Reimplemented in [CopleyCAN](#).

5.22.3.9 `const Error * Xmit (CanFrame & frame, Timeout timeout = 0)`

Write a CAN frame to the CAN network.

Parameters

<i>frame</i>	A reference to the frame to write.
<i>timeout</i>	The time to wait for the frame to be successfully sent. If the timeout is 0, the frame is written to the output queue and the function returns without waiting for it to be sent. If the timeout is <0 then the function will delay forever.

Returns

A pointer to an error object, or NULL on success.

5.22.3.10 `const Error * XmitFrame (CanFrame & frame, Timeout timeout) [protected],[virtual]`

Write a CAN frame to the CAN network.

This is called by the public Xmit function, and must be implemented by the actual [CanInterface](#) class. It handles the hardware specific details of writing a message to the network.

Parameters

<i>frame</i>	A reference to the frame to write.
<i>timeout</i>	The time to wait for the frame to be successfully sent. If the timeout is 0, the frame is written to the output queue and the function returns without waiting for it to be sent. If the timeout is <0 then the function will delay forever.

Returns

A pointer to an error object, or NULL on success.

Reimplemented in [KvaserCAN](#), [IxxatCANV3](#), [IxxatCAN](#), and [CopleyCAN](#).

5.22.4 Member Data Documentation

5.22.4.1 `char* portName [protected]`

This string is initialized by the default constructor.

It may be used to identify which CAN port to open, etc.

The documentation for this class was generated from the following files:

- [CML_Can.h](#)
- [Can.cpp](#)

5.23 CanNetworkConfig Struct Reference

CANopen [Node](#) ID and bit rate configuration.

Public Member Functions

- [CanNetworkConfig](#) ()
Default constructor. Set default values.
- void [FromAmpFormat](#) (uint16 a)
Load the structure from a 16-bit word.
- [uint16 ToAmpFormat](#) (void)
Encode the contents of the structure into a 16-bit word in the format used by the amplifier.

Public Attributes

- [uint8 numInPins](#)
Number of general purpose input pins to read on startup for node ID selection.
- bool [useSwitch](#)
If true, use the CAN address switch as part of the node ID calculation.
- [uint8 offset](#)
Offset added to the value read from the input pins & address switch.
- [CAN_BIT_RATE](#) [bitRate](#)
CANopen network bit rate to use.
- [uint32 pinMapping](#)
Input pin mapping for node ID selection.
- [uint16 quickStop](#)
CANopen quick stop option code.
- [uint16 shutDownOption](#)
CANopen shutdown option code.
- [uint16 disableOption](#)
CANopen disable option code.
- [uint16 haltOption](#)
CANopen halt option code.
- [uint16 heartbeat](#)
CANopen heartbeat time.
- [uint16 nodeGuard](#)
CANopen [Node](#) Guard time.
- [uint16 nodeGuardLife](#)
CANopen [Node](#) Guarding Life time factor.

5.23.1 Detailed Description

CANopen [Node ID](#) and bit rate configuration.

The amplifier's CANopen node ID and network bit rate can be configured using the members of this structure. Note that the ID and bit rate are only set on power-up or reset, so after programming a new configuration the amplifier must be reset for the configuration to become active.

The CANopen node ID is a 7 bit number in the range 1 to 128. The value 0 is reserved and is not considered a valid node ID. Selecting a node ID of 0 will cause the amplifier to stop communicating over the CANopen network.

The node ID is calculated using a combination of any of the following:

- The CAN address switch on amplifiers which support this feature
- 0 to 7 general purpose input pins.
- A programmable offset in the range 0 to 128.

On startup, the input pins are read first. The inputs that will be used for CAN address selection are the highest numbered pins available. For example, on an amplifier with 12 input pins (0 to 11), if 3 inputs are used for CANopen node ID selection, then the pins used will be 9, 10 and 11. These three pins will result in a base node address between 0 and 7.

If the CAN address switch is being used, then the value read from the input pins will be shifted up four bits (multiplied by 16) and the value of the input switch will be added to it.

Finally, the programmed offset will be added to the value read from the input pins and address switch. The lowest 7 bits of this sum will be used as the CANopen node ID. If this value results in an ID of zero, the CANopen interface will be disabled.

For example, to program an amplifier to ignore input pins and the address switch, and just set a fixed ID of 7, set the number of input pins to zero, turn off the address switch, and set the offset to 7.

5.23.2 Member Function Documentation

5.23.2.1 void FromAmpFormat (uint16 a)

Load the structure from a 16-bit word.

Parameters

<i>a</i>	A 16-bit value encoding the network configuration. See the amplifier documentation for details on the format.
----------	---

5.23.2.2 uint16 ToAmpFormat (void)

Encode the contents of the structure into a 16-bit word in the format used by the amplifier.

See the amplifier documentation for details on this format.

Returns

A 16-bit word representing the contents of this structure.

5.23.3 Member Data Documentation

5.23.3.1 uint16 heartbeat

CANopen heartbeat time.

The frequency at which the amp will produce heartbeat messages. This parameter may be set to zero to disable heartbeat production.

5.23.3.2 uint16 nodeGuard

CANopen [Node](#) Guard time.

This parameter gives the time between nodeguarding requests that are sent from the CANopen master to this amplifier

5.23.3.3 uint16 nodeGuardLife

CANopen [Node](#) Guarding Life time factor.

This object gives a multiple of the CANopen [Node](#) Guarding Time

5.23.3.4 uint8 numInPins

Number of general purpose input pins to read on startup for node ID selection.

This parameter may be set from 0 to 7.

5.23.3.5 uint8 offset

Offset added to the value read from the input pins & address switch.

5.23.3.6 uint32 pinMapping

Input pin mapping for node ID selection.

When network node id indicates that 1 or more input pins will be used to select the node ID, this parameter is used to map input pins to ID bits. Available after 3.35 firmware. See documentation

5.23.3.7 bool useSwitch

If true, use the CAN address switch as part of the node ID calculation.

Note that on amplifiers which do not support this switch this parameter is ignored.

The documentation for this struct was generated from the following files:

- [CML_AmpStruct.h](#)
- [AmpStruct.cpp](#)

5.24 CanOpen Class Reference

The [CanOpen](#) class is the top level interface into the CANopen network.

Inheritance diagram for CanOpen:

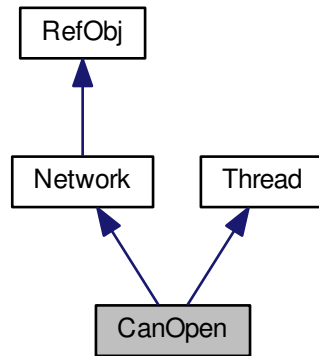

Collaboration diagram for CanOpen:

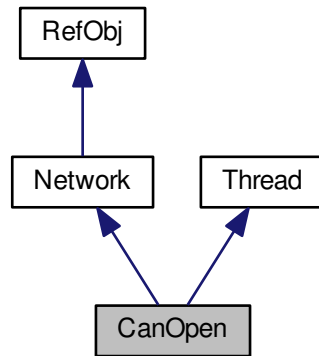

Public Member Functions

- [CanOpen](#) (void)
Default constructor.
- virtual [~CanOpen](#) (void)
CanOpen Destructor.
- const [Error](#) * [Open](#) ([CanInterface](#) &can)
Open the CANopen network.
- const [Error](#) * [Open](#) ([CanInterface](#) &can, [CanOpenSettings](#) &settings)

- Open the CANopen network.*

 - void **Close** (void)

Close the CANopen network.
- **NetworkType GetNetworkType** (void)

Return the network type.
- const **Error * AttachNode** (**Node *n**)

Attach the passed node to this network.
- const **Error * DetachNode** (**Node *n**)

Detach the passed node from this network.
- const **Error * SetNodeGuard** (**Node *n**, **GuardProtocol** type, Timeout timeout=50, **uint8** life=3)

Configure the node guarding protocol for a CANopen node.
- const **Error * ResetNode** (**Node *n**)

Send a network management message to reset the specified node.
- const **Error * ResetComm** (**Node *n**)

Send a network management message to reset the communications of the specified node.
- const **Error * PreOpNode** (**Node *n**)

Send a network management message to put the specified node in pre-operational state.
- const **Error * StartNode** (**Node *n**)

Send a network management message to start the specified node.
- const **Error * StopNode** (**Node *n**)

Send a network management message to stop the specified node.
- const **Error * BootModeNode** (**Node *n**)

For CANopen networks, this is the same as `CanOpen::StopNode()`;
- const **Error * Xmit** (**CanFrame** &frame, Timeout timeout=2000)

Transmit a frame over the CANopen network.
- const **Error * XmitSDO** (**Node *n**, **uint8** *data, **uint16** len, **uint16** *ret, Timeout timeout=2000)

Transmit an SDO message over the CANopen network and wait for a response.
- const **Error * XmitPDO** (class **PDO** *pdo, Timeout timeout=2000)

Transmit a PDO over the CANopen network.
- **int16 GetSynchProducer** (void)

Return the node ID of the synch producer for this network.
- void **SetSynchProducer** (**int16** nodeID)

Set the node ID of the synch producer for this network.
- **int32 GetErrorFrameCounter** (void)

Return the number of error frames received over then CAN network since the last time the counter was cleared.
- void **ClearErrorFrameCounter** (void)

Clear the error frame counter.
- const **Error * EnableReceiver** (**uint32** canMsgID, class **Receiver** *rcvr)

Enable reception handling of the message identified by this `Receiver` object.
- const **Error * DisableReceiver** (**uint32** canMsgID)

Disable reception handling of a particular CANopen message type.

Additional Inherited Members

5.24.1 Detailed Description

The [CanOpen](#) class is the top level interface into the CANopen network.

There should be at least one object of this class in every CANopen based application. Normally, only one object will be necessary, however if more than one independent CANopen network is in use, then more than one object will be necessary.

On startup, a low level CAN interface object should be created. This object should be passed to the CANopen object's [Open\(\)](#) method.

5.24.2 Constructor & Destructor Documentation

5.24.2.1 [CanOpen](#) (void)

Default constructor.

Simply initializes some local variables.

5.24.2.2 [~CanOpen](#) (void) [virtual]

[CanOpen](#) Destructor.

This closes the CANopen network.

5.24.3 Member Function Documentation

5.24.3.1 `const Error * AttachNode (Node * n)` [virtual]

Attach the passed node to this network.

This function is called by the node object when it's initialized. It connects the node to the CANopen network object so that messages bound for the node can be properly delivered.

Parameters

<i>n</i>	Pointer to the node to attach to the network.
----------	---

Returns

A pointer to an error object, or NULL on success.

Implements [Network](#).

5.24.3.2 `const Error * BootModeNode (Node * n)` [virtual]

For CANopen networks, this is the same as [CanOpen::StopNode\(\)](#);

Parameters

<i>n</i>	Pointer to the node to stop.
----------	------------------------------

Returns

A pointer to an error object, or NULL on success.

Implements [Network](#).

5.24.3.3 void Close (void)

Close the CANopen network.

This disables all receivers and stops the thread that listens on the CAN network.

5.24.3.4 const Error * DetachNode (Node * n) [virtual]

Detach the passed node from this network.

This function is called by the node object when it's uninitialized. It removes the connection between the node and the CANopen network object.

Parameters

<i>n</i>	Pointer to the node to detach from the network.
----------	---

Returns

A pointer to an error object, or NULL on success.

Implements [Network](#).

5.24.3.5 const Error * DisableReceiver (uint32 canMsgID)

Disable reception handling of a particular CANopen message type.

Parameters

<i>canMsgID</i>	The CAN message ID.
-----------------	---------------------

Returns

A pointer to an error object, or NULL on success.

5.24.3.6 const Error * EnableReceiver (uint32 msgID, class Receiver * rcvr)

Enable reception handling of the message identified by this [Receiver](#) object.

The receiver is enabled by adding it to a binary tree of receiver objects maintained by the [CanOpen](#) object.

Parameters

<i>msgID</i>	The CAN message ID to associate with this receiver.
<i>rcvr</i>	Pointer to the receiver to add

Returns

A pointer to an error object, or NULL on success.

5.24.3.7 `int32 GetErrorFrameCounter (void) [inline]`

Return the number of error frames received over the CAN network since the last time the counter was cleared.

Returns

The number of error frames received since the last call to [CanOpen::ClearErrorFrameCounter\(\)](#);

5.24.3.8 `NetworkType GetNetworkType (void) [inline],[virtual]`

Return the network type.

Returns

Always returns the value `NET_TYPE_CANOPEN`

Implements [Network](#).

5.24.3.9 `int16 GetSynchProducer (void) [inline]`

Return the node ID of the synch producer for this network.

Returns

The synch producer node ID, or 0 if no synch producer has been registered.

5.24.3.10 `const Error * Open (CanInterface & can)`

Open the CANopen network.

This function performs the one time initialization necessary to communication via the CANopen network. It should be the first function called for the CANopen object.

All configurable settings will be set to their defaults when the [CanOpen](#) object is opened using this method. For a list of [CanOpen](#) object settings and their default values, please see the [CanOpenSettings](#) object.

Parameters

<i>can</i>	A reference to the CAN interface object that will be used for all low level communication over the network.
------------	---

Returns

A pointer to an error object, or NULL on success.

5.24.3.11 `const Error * Open (CanInterface & ci, CanOpenSettings & settings)`

Open the CANopen network.

This function performs the one time initialization necessary to communication via the CANopen network. It should be the first function called for the CANopen object.

This version of the Open function takes a [CanOpenSettings](#) object reference as it's second parameter. The data members of the settings object may be used to configure some of the [CanOpen](#) object's behavior.

Parameters

<i>ci</i>	A reference to the CAN interface object that will be used for all low level communication over the network.
<i>settings</i>	A reference to a CanOpenSettings object. This object is used to customize the behavior of the CanOpen object.

Returns

A pointer to an error object, or NULL on success.

5.24.3.12 `const Error * PreOpNode (Node * n) [virtual]`

Send a network management message to put the specified node in pre-operational state.

Parameters

<i>n</i>	Pointer to the node.
----------	----------------------

Returns

A pointer to an error object, or NULL on success.

Implements [Network](#).

5.24.3.13 `const Error * ResetComm (Node * n) [virtual]`

Send a network management message to reset the communications of the specified node.

All nodes have their communications reset if the passed node ID is zero.

Parameters

<i>n</i>	A pointer to the node to reset
----------	--------------------------------

Returns

A pointer to an error object, or NULL on success.

Implements [Network](#).

5.24.3.14 `const Error * ResetNode (Node * n) [virtual]`

Send a network management message to reset the specified node.

All nodes are reset if the passed node ID is zero.

Parameters

<i>n</i>	A pointer to the node to reset
----------	--------------------------------

Returns

A pointer to an error object, or NULL on success.

Implements [Network](#).

5.24.3.15 `const Error * SetNodeGuard (Node * n, GuardProtocol type, Timeout to = 50, uint8 life = 3) [virtual]`

Configure the node guarding protocol for a CANopen node.

Parameters

<i>n</i>	The node to configure guarding on.
<i>type</i>	The type of node guarding to configure.
<i>to</i>	A timeout (milliseconds) to use for this node guarding protocol. If not specified, this parameter defaults to 50 milliseconds.
<i>life</i>	A life time factor for use with the node guarding protocol (default 3). Only the node guarding protocol uses this parameter, it may be omitted for other node guarding types.

Returns

A pointer to an error object, or NULL on success.

Implements [Network](#).

5.24.3.16 `void SetSynchProducer (int16 nodeID) [inline]`

Set the node ID of the synch producer for this network.

Parameters

<i>nodeID</i>	The new synch producer node ID, or 0 for none.
---------------	--

5.24.3.17 `const Error * StartNode (Node * n) [virtual]`

Send a network management message to start the specified node.

Parameters

<i>n</i>	Pointer to the node to start.
----------	-------------------------------

Returns

A pointer to an error object, or NULL on success.

Implements [Network](#).

5.24.3.18 `const Error * StopNode (Node * n) [virtual]`

Send a network management message to stop the specified node.

Parameters

<i>n</i>	Pointer to the node to stop.
----------	------------------------------

Returns

A pointer to an error object, or NULL on success.

Implements [Network](#).

5.24.3.19 `const Error * Xmit (CanFrame & frame, Timeout timeout = 2000)`

Transmit a frame over the CANopen network.

Parameters

<i>frame</i>	Reference to the frame to transmit
<i>timeout</i>	Max time to wait for the frame to be sent.

Returns

A pointer to an error object, or NULL on success.

5.24.3.20 `const Error * XmitPDO (class PDO * pdo, Timeout timeout = 2000) [virtual]`

Transmit a [PDO](#) over the CANopen network.

If the [PDO](#) is a transmit [PDO](#) (i.e. the type of [PDO](#) that's normally sent from the node and received by the master), then a remote request is sent.

Parameters

<i>pdo</i>	Pointer to the PDO to be transmitted.
<i>timeout</i>	Max time to wait for the PDO to be sent.

Returns

A pointer to an error object, or NULL on success.

Implements [Network](#).

5.24.3.21 `const Error * XmitSDO (Node * n, uint8 * buff, uint16 len, uint16 * ret, Timeout timeout = 2000) [virtual]`

Transmit an [SDO](#) message over the CANopen network and wait for a response.

The [SDO](#) should have already been formatted into the passed array. This function assigns the standard CAN message ID and transmits the resulting CAN frame.

Parameters

<i>n</i>	Pointer to the node to whom the SDO is addressed.
<i>buff</i>	Buffer containing the formatted SDO data
<i>len</i>	Length of the SDO data in bytes. Should be 8 bytes for standard CANopen SDOs.
<i>ret</i>	Pointer to a location where the number of received bytes will be stored on success.
<i>timeout</i>	Max time to wait for the PDO to be sent.

Returns

A pointer to an error object, or NULL on success.

Implements [Network](#).

The documentation for this class was generated from the following files:

- [CML_CanOpen.h](#)
- [CanOpen.cpp](#)

5.25 CanOpenError Class Reference

This class holds the error codes that describe CANopen error conditions.

Inheritance diagram for CanOpenError:

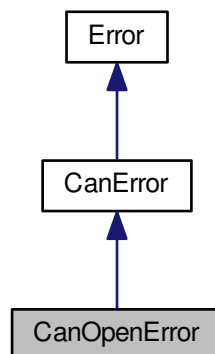

Collaboration diagram for CanOpenError:

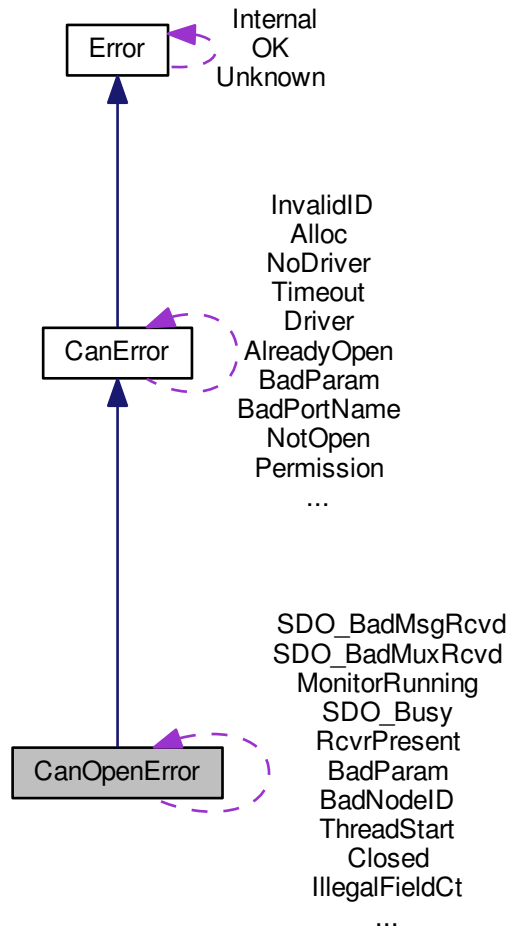

Static Public Attributes

- static const [CanOpenError ThreadStart](#)
Indicates that the specified port name is invalid.
- static const [CanOpenError BadParam](#)
One of the parameters passed to the CANopen function is invalid.
- static const [CanOpenError SDO_Busy](#)
The SDO object is busy.
- static const [CanOpenError SDO_Timeout](#)
The SDO up/download failed with a timeout.
- static const [CanOpenError SDO_Unknown](#)
Some unknown error occurred.

- static const [CanOpenError SDO_BadMuxRcvd](#)
The mux (index/sub-index) received in a SDO message is inconsistent with the object being accessed.
- static const [CanOpenError SDO_BadMsgRcvd](#)
An improperly formatted SDO message was received.
- static const [CanOpenError BadNodeID](#)
An illegal node ID was specified.
- static const [CanOpenError NotInitialized](#)
The object being used has not been initialized.
- static const [CanOpenError Initialized](#)
An attempt was made to initialize an object that has already been initialized, and doesn't allow multiple initialization.
- static const [CanOpenError NotSupported](#)
The requested feature is not supported by this node.
- static const [CanOpenError MonitorRunning](#)
Monitor already running - An attempt is made to start the heartbeat or node guarding and it's already running.
- static const [CanOpenError IllegalFieldCt](#)
The node returned an illegal field count for the object being requested in it's object dictionary.
- static const [CanOpenError RcvrNotFound](#)
An attempt was made to disable a receiver that wasn't enabled.
- static const [CanOpenError RcvrPresent](#)
An attempt was made to enable a receiver that was already enabled.
- static const [CanOpenError Closed](#)
The CANopen port is closed.

Additional Inherited Members

5.25.1 Detailed Description

This class holds the error codes that describe CANopen error conditions.

5.25.2 Member Data Documentation

5.25.2.1 const [CanOpenError IllegalFieldCt](#) [static]

The node returned an illegal field count for the object being requested in it's object dictionary.

5.25.2.2 const [CanOpenError Initialized](#) [static]

An attempt was made to initialize an object that has already been initialized, and doesn't allow multiple initialization.

5.25.2.3 const [CanOpenError MonitorRunning](#) [static]

Monitor already running - An attempt is made to start the heartbeat or node guarding and it's already running.

5.25.2.4 const [CanOpenError NotInitialized](#) [static]

The object being used has not been initialized.

This error indicates a coding error, i.e. trying to use a [Receiver](#) object without initializing it.

5.25.2.5 `const CanOpenError SDO_BadMuxRcvd [static]`

The mux (index/sub-index) received in a [SDO](#) message is inconsistent with the object being accessed.

The documentation for this class was generated from the following file:

- [CML_CanOpen.h](#)

5.26 CanOpenNodeInfo Struct Reference

The [CanOpenNodeInfo](#) structure holds some data required by the CANopen network interface which is present in every node it manages.

Inheritance diagram for CanOpenNodeInfo:

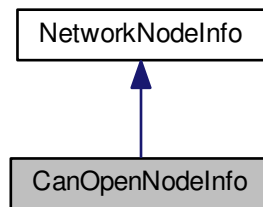

Collaboration diagram for CanOpenNodeInfo:

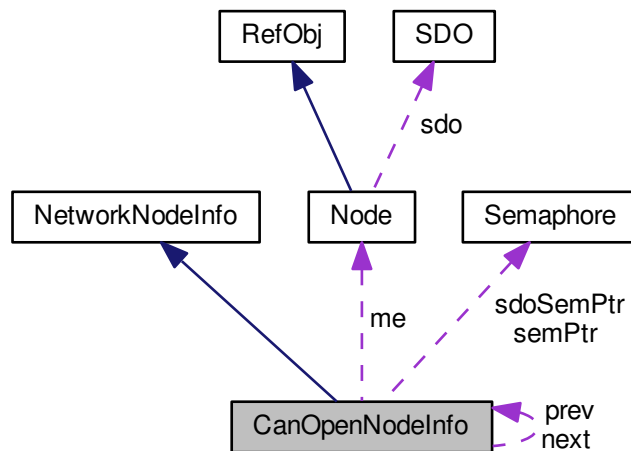

Public Attributes

- [uint32 eventTime](#)
Time (milliseconds) when next guarding event is due.
- [int16 guardToggle](#)
This value keeps track of the toggle bit used with node guarding.
- [int32 guardTimeout](#)
This variable gives the guard time in milliseconds.
- [uint8 lifeTime](#)
Max number of guard timeouts before an error is generated.
- [uint8 lifeCounter](#)
Counter used to track guard timeouts.
- [GuardProtocol guardType](#)
This variable identifies the type of guard protocol being used by this node.
- [NodeState desired](#)
State I'm waiting for.
- [Semaphore * semPtr](#)
Pointer to semaphore used when waiting for state change.
- [Semaphore * sdoSemPtr](#)
Pointer to semaphore used when waiting for an [SDO](#) response.
- [uint8 * sdoBuff](#)
Pointer to [SDO](#) data buffer.

5.26.1 Detailed Description

The [CanOpenNodeInfo](#) structure holds some data required by the CANopen network interface which is present in every node it manages.

The contents of this structure should be considered the private property of the CANopen class.

5.26.2 Member Data Documentation

5.26.2.1 [int32 guardTimeout](#)

This variable gives the guard time in milliseconds.

It's used both in heartbeat and node guarding modes.

5.26.2.2 [int16 guardToggle](#)

This value keeps track of the toggle bit used with node guarding.

It's set to -1 if the toggle bit isn't used.

5.26.2.3 [GuardProtocol guardType](#)

This variable identifies the type of guard protocol being used by this node.

The options are none, heartbeat monitor, and node guarding.

The documentation for this struct was generated from the following files:

- [CML_CanOpen.h](#)
- [CanOpen.cpp](#)

5.27 CanOpenSettings Class Reference

Configuration object used to customize global settings for the CANopen network.

Public Member Functions

- [CanOpenSettings](#) ()
Default constructor for [CanOpenSettings](#) object.

Public Attributes

- int [readThreadPriority](#)
Defines the read thread priority.
- bool [useAsTimingReference](#)
If true, the master (i.e.
- [uint32](#) [syncID](#)
CAN message ID of the SYNC message.
- [uint32](#) [timeID](#)
CAN message ID of the timestamp message.

5.27.1 Detailed Description

Configuration object used to customize global settings for the CANopen network.

An object of this type may be passed to the [CanOpen::Open\(\)](#) method when the network is first opened.

If no [CanOpenSettings](#) object is passed to the [CanOpen::Open\(\)](#) method, then the behavior is exactly the same as passing a [CanOpenSettings](#) object with the default settings.

5.27.2 Constructor & Destructor Documentation

5.27.2.1 [CanOpenSettings](#) (void)

Default constructor for [CanOpenSettings](#) object.

This constructor simply sets all the settings to their default values.

5.27.3 Member Data Documentation

5.27.3.1 int [readThreadPriority](#)

Defines the read thread priority.

The read thread is started when the [CanOpen](#) object is first opened (using [CanOpen::Open\(\)](#)). This thread is responsible for reading messages from the CANopen network and calling the message handlers associated with them. It should be run at a relatively high priority. Default: 9

5.27.3.2 uint32 syncID

CAN message ID of the SYNC message.

This is only used if the [CanOpen](#) object will act as the timing reference in the system. If so, this ID must match the corresponding value passed in the [AmpSettings](#) object. Default 0x80

5.27.3.3 uint32 timeID

CAN message ID of the timestamp message.

This is only used if the [CanOpen](#) object will act as the timing reference in the system. If so, this ID must match the corresponding value passed in the [AmpSettings](#) object. Default 0x180

5.27.3.4 bool useAsTimingReference

If true, the master (i.e.

the computer that CML is running on) will generate sync timing messages used to synchronize the clocks of the nodes on the CANopen network. This is only possible if the CAN interface being used is able to capture accurate PC timer based time stamps of the received CAN frames. Since this isn't supported by most CAN interfaces, the default setting for this is false. If false, one of the nodes on the CANopen network will generate the time stamps. Default: false

The documentation for this class was generated from the following files:

- [CML_CanOpen.h](#)
- [CanOpen.cpp](#)

5.28 CopleyCAN Class Reference

This class extends the generic [CanInterface](#) class into a working interface for the Copley can device driver.

Inheritance diagram for CopleyCAN:

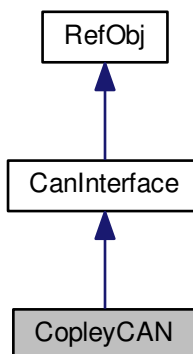

Collaboration diagram for CopleyCAN:

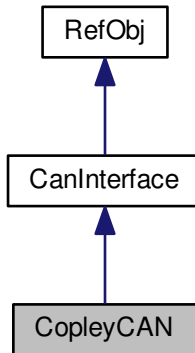

Public Member Functions

- [CopleyCAN](#) (void)
Construct a CAN object.
- [CopleyCAN](#) (const char *port)
Construct a new CAN object.
- virtual [~CopleyCAN](#) (void)
Destructor for [CopleyCAN](#) object.
- const [Error](#) * [Open](#) (void)
Open the CAN bus.
- const [Error](#) * [Close](#) (void)
Close the CAN interface.
- const [Error](#) * [SetBaud](#) (int32 baud)
Set the CAN interface baud rate.
- bool [SupportsTimestamps](#) (void)
Return true if the CAN interface supports timestamps on received frames.

Protected Member Functions

- const [Error](#) * [RecvFrame](#) ([CanFrame](#) &frame, Timeout timeout)
Receive the next CAN frame.
- const [Error](#) * [XmitFrame](#) ([CanFrame](#) &frame, Timeout timeout)
Write a CAN frame to the CAN network.

Protected Attributes

- int [open](#)
tracks the state of the interface as open or closed.
- int32 [baud](#)
Holds a copy of the last baud rate set.
- void * [local](#)
This pointer is used to keep track of private data used by the driver.

Additional Inherited Members

5.28.1 Detailed Description

This class extends the generic [CanInterface](#) class into a working interface for the Copley can device driver.

5.28.2 Member Function Documentation

5.28.2.1 `const Error * Close (void) [virtual]`

Close the CAN interface.

Returns

A CAN error object identifying the error.

Reimplemented from [CanInterface](#).

5.28.2.2 `const Error * Open (void) [virtual]`

Open the CAN bus.

Returns

A CAN error object identifying the error.

Reimplemented from [CanInterface](#).

5.28.2.3 `const Error * RecvFrame (CanFrame & frame, Timeout timeout) [protected], [virtual]`

Receive the next CAN frame.

Parameters

<i>frame</i>	A reference to the frame object that will be filled by the read.
<i>timeout</i>	The timeout (ms) to wait for the frame. A timeout of 0 will return immediately if no data is available. A timeout of < 0 will wait forever.

Returns

A CAN error object identifying the error.

Reimplemented from [CanInterface](#).

5.28.2.4 `const Error * SetBaud (int32 b) [virtual]`

Set the CAN interface baud rate.

This should be set before the CAN interface is open.

Parameters

<i>b</i>	The baud rate to set.
----------	-----------------------

Returns

A CAN error object identifying the error.

Reimplemented from [CanInterface](#).

5.28.2.5 `bool SupportsTimestamps (void) [inline],[virtual]`

Return true if the CAN interface supports timestamps on received frames.

Returns

true if timestamps are supported

Reimplemented from [CanInterface](#).

5.28.2.6 `const Error * XmitFrame (CanFrame & frame, Timeout timeout) [protected],[virtual]`

Write a CAN frame to the CAN network.

Parameters

<i>frame</i>	A reference to the frame to write.
<i>timeout</i>	The time to wait for the frame to be successfully sent. If the timeout is 0, the frame is written to the output queue and the function returns without waiting for it to be sent. If the timeout is <0 then the function will delay forever.

Returns

A CAN error object identifying the error.

Reimplemented from [CanInterface](#).

5.28.3 Member Data Documentation

5.28.3.1 `void* local [protected]`

This pointer is used to keep track of private data used by the driver.

The documentation for this class was generated from the following files:

- [can_copley.h](#)
- [can_copley.cpp](#)

5.29 CopleyIO Class Reference

This class represents a Copley CANopen I/O module.

Inheritance diagram for CopleyIO:

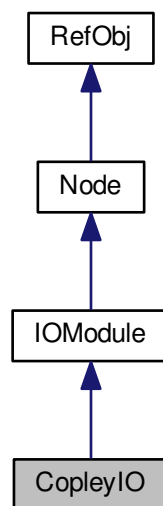

Collaboration diagram for CopleyIO:

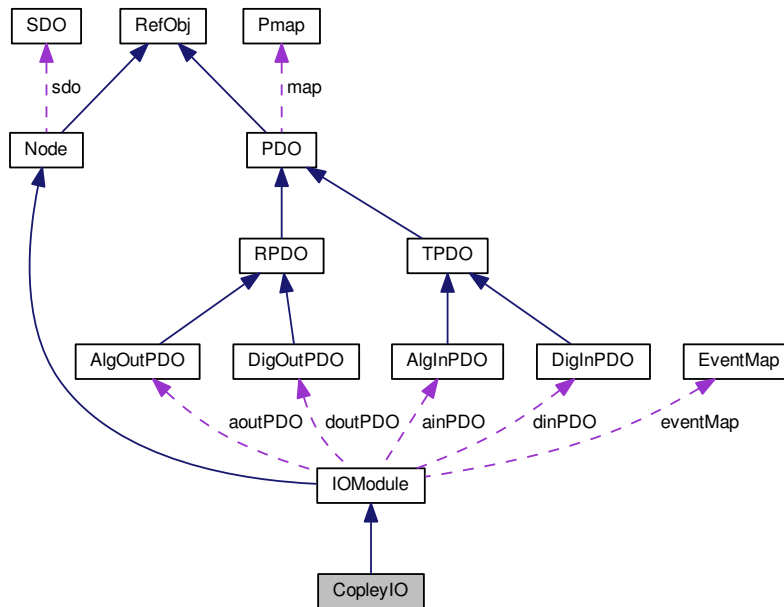

Public Member Functions

- [CopleyIO](#) (void)
Default constructor for a Copley I/O module.
- [CopleyIO](#) ([Network](#) &net, [int16](#) nodeID)
Construct a [CopleyIO](#) object and initialize it using default settings.
- [CopleyIO](#) ([Network](#) &net, [int16](#) nodeID, [IOModuleSettings](#) &settings)
Construct a [CopleyIO](#) object and initialize it using custom settings.
- virtual [~CopleyIO](#) ()
Virtual destructor for the [IOModule](#) object.
- virtual const [Error](#) * [Init](#) ([Network](#) &net, [int16](#) nodeID)
Initialize a Copley IO module using default settings.
- virtual const [Error](#) * [Init](#) ([Network](#) &net, [int16](#) nodeID, [IOModuleSettings](#) &settings)
Initialize an I/O module using custom settings.
- const [Error](#) * [GetIOInfo](#) ([CopleyIOInfo](#) &info)
Read the I/O Module information parameters from the drive.
- const [Error](#) * [GetIODigi](#) ([CopleyIODigi](#) &digi)
Read the I/O Module digital parameters from the drive.
- const [Error](#) * [GetIOAnlg](#) ([CopleyIOAnlg](#) &anlg)
Read the I/O Module analog parameters from the drive.
- const [Error](#) * [GetIOPWM](#) ([CopleyIOPWM](#) &pwm, [CopleyIOInfo](#) &info)
Read the I/O Module PWM parameters from the drive.
- const [Error](#) * [GetIOCfg](#) ([CopleyIOCfg](#) &cfg)

- Read the complete I/O configuration from the module and return it in the passed structure.*

 - const [Error](#) * [SetIOInfo](#) ([CopleyIOInfo](#) &info)

Write the I/O Module information parameters to the drive.
- const [Error](#) * [SetIODigi](#) ([CopleyIODigi](#) &digi)

Write the I/O Module digital parameters to the drive.
- const [Error](#) * [SetIOAnlg](#) ([CopleyIOAnlg](#) &anlg)

Write the I/O Module analog parameters to the drive.
- const [Error](#) * [SetIOPWM](#) ([CopleyIOPWM](#) &pwm, [CopleyIOInfo](#) &info)

Write the I/O Module PWM parameters to the drive.
- const [Error](#) * [SetIOConfig](#) ([CopleyIOCfg](#) &cfg)

Write the complete I/O configuration from the module and return it in the passed structure.
- const [Error](#) * [SaveIOConfig](#) (void)

Save all I/O parameters to internal flash memory.
- const [Error](#) * [SaveIOConfig](#) ([CopleyIOCfg](#) &cfg)

Upload the passed io module configuration to the module's working memory, and then copy that working memory to flash.
- const [Error](#) * [LoadFromFile](#) (const char *name, int &line)

Load the specified io module data file.
- const [Error](#) * [SerialCmd](#) (uint8 opcode, uint8 &ct, uint8 max, uint16 *data)

Send a serial port message to a Copley device over the CANopen network.

Additional Inherited Members

5.29.1 Detailed Description

This class represents a Copley CANopen I/O module.

It extends the standard I/O module with methods that can be used to restore from a CME generated I/O settings file.

5.29.2 Constructor & Destructor Documentation

5.29.2.1 [CopleyIO](#) ([Network](#) & net, int16 nodeID)

Construct a [CopleyIO](#) object and initialize it using default settings.

Parameters

<i>net</i>	The Network object that this module is associated with.
<i>nodeID</i>	The node ID of the module on the network.

5.29.2.2 [CopleyIO](#) ([Network](#) & net, int16 nodeID, [IOModuleSettings](#) & settings)

Construct a [CopleyIO](#) object and initialize it using custom settings.

Parameters

<i>net</i>	The Network object that this module is associated with.
------------	---

<i>nodeID</i>	The node ID of the module on the network.
<i>settings</i>	The settings to use when configuring the module

5.29.3 Member Function Documentation

5.29.3.1 `const Error * GetIOAnlg (CopleyIOAnlg & anlg)`

Read the I/O Module analog parameters from the drive.

Parameters

<i>anlg</i>	A structure that will be filled with the analog I/O values
-------------	--

Returns

A pointer to an error object, or NULL on success

5.29.3.2 `const Error * GetIOCfg (CopleyIOCfg & cfg)`

Read the complete I/O configuration from the module and return it in the passed structure.

This structure holds every module parameter that can be stored to the module's internal flash memory. The contents of the structure represent the complete I/O configuration.

Parameters

<i>cfg</i>	The structure which will hold the uploaded configuration.
------------	---

Returns

A pointer to an error object, or NULL on success

5.29.3.3 `const Error * GetIODigi (CopleyIODigi & digi)`

Read the I/O Module digital parameters from the drive.

Parameters

<i>digi</i>	A structure that will be filled with the digital I/O values
-------------	---

Returns

A pointer to an error object, or NULL on success

5.29.3.4 `const Error * GetIOInfo (CopleyIOInfo & info)`

Read the I/O Module information parameters from the drive.

Parameters

<i>info</i>	A structure that will be filled with the I/O module info
-------------	--

Returns

A pointer to an error object, or NULL on success

5.29.3.5 `const Error * GetIOPWM (CopleyIOPWM & pwm, CopleyIOInfo & info)`

Read the I/O Module PWM parameters from the drive.

Parameters

<i>pwm</i>	A structure that will be filled with the PWM I/O values
<i>info</i>	A structure containing additional information about the module.

Returns

A pointer to an error object, or NULL on success

5.29.3.6 `const Error * Init (Network & net, int16 nodeID) [virtual]`

Initialize a Copley IO module using default settings.

This function associates the object with the CANopen network it will be used on.

Parameters

<i>net</i>	The Network object that this module is associated with.
<i>nodeID</i>	The node ID of the module on the network.

Returns

A pointer to an error object, or NULL on success

Reimplemented from [IOModule](#).

5.29.3.7 `const Error * Init (Network & net, int16 nodeID, IOModuleSettings & settings) [virtual]`

Initialize an I/O module using custom settings.

This function associates the object with the CANopen network it will be used on.

Parameters

<i>net</i>	The Network object that this module is associated with.
<i>nodeID</i>	The node ID of the module on the network.
<i>settings</i>	The settings to use when configuring the module

Returns

A pointer to an error object, or NULL on success

Reimplemented from [IOModule](#).

5.29.3.8 `const Error * LoadFromFile (const char * name, int & line)`

Load the specified io module data file.

This function presently supports loading *.cci files created by the CME-2 program, version 1 and later.

Parameters

<i>name</i>	The name (and optionally path) of the file to load
<i>line</i>	If not NULL, the last line number read from the file is returned here. This is useful for finding file format errors.

Returns

A pointer to an error object, or NULL on success.

5.29.3.9 `const Error * SaveIOConfig (void)`

Save all I/O parameters to internal flash memory.

Flash memory is a type of non-volatile RAM which allows module parameters to be saved between power cycles. When this function is called, any module parameters that may be stored to flash will be copied from their working (RAM) locations to the stored (flash) locations.

For a list of those I/O parameters which may be saved to flash memory, see the IOConfig structure. Every member of that structure represents an io module parameter that may be saved to flash.

Returns

A pointer to an error object, or NULL on success

5.29.3.10 `const Error * SaveIOConfig (CopleyIOCfg & cfg)`

Upload the passed io module configuration to the module's working memory, and then copy that working memory to flash.

Parameters

<i>cfg</i>	The structure which holds the new configuration.
------------	--

Returns

A pointer to an error object, or NULL on success

5.29.3.11 `const Error * SerialCmd (uint8 opcode, uint8 & ct, uint8 max, uint16 * data)`

Send a serial port message to a Copley device over the CANopen network.

Copley devices use serial ports for some basic configuration purposes. Most of the functions available over the serial interface are also available in the CANopen object dictionary, but not everything.

This function allows a native serial port command to be sent over the CANopen network. It allows any remaining features of the device to be accessed when only a CANopen connection is available.

Parameters

<i>opcode</i>	The command code to be sent to the amplifier.
<i>ct</i>	The number of 16-bit words of data to be sent to the amplifier. On return, this parameter will hold the number of 16-bit words of response data passed back from the amplifier.
<i>max</i>	The maximum number of words of response data that the data array can hold.
<i>data</i>	An array of data to be passed to the node with the command. On return, any response data (up to max words) will be passed here. If this parameter is not specified, then no data will be passed or returned regardless of the values passed in max and ct.

Returns

An error object, or null on success.

5.29.3.12 `const Error * SetIOAnlg (CopleyIOAnlg & anlg)`

Write the I/O Module analog parameters to the drive.

Parameters

<i>anlg</i>	A structure that will be filled with the analog I/O values
-------------	--

Returns

A pointer to an error object, or NULL on success

5.29.3.13 `const Error * SetIOConfig (CopleyIOCfg & cfg)`

Write the complete I/O configuration from the module and return it in the passed structure.

This structure holds every I/O parameter that can be stored to the module's internal flash memory. The contents of the structure represent the complete I/O configuration.

Parameters

<i>cfg</i>	The structure which will hold the uploaded configuration.
------------	---

Returns

A pointer to an error object, or NULL on success

5.29.3.14 `const Error * SetIODigi (CopleyIODigi & digi)`

Write the I/O Module digital parameters to the drive.

Parameters

<i>digi</i>	A structure that will be filled with the digital I/O values
-------------	---

Returns

A pointer to an error object, or NULL on success

5.29.3.15 `const Error * SetIOInfo (CopleyIOInfo & info)`

Write the I/O Module information parameters to the drive.

Parameters

<i>info</i>	A structure that will be filled with the I/O module info
-------------	--

Returns

A pointer to an error object, or NULL on success

5.29.3.16 `const Error * SetIOPWM (CopleyIOPWM & pwm, CopleyIOInfo & info)`

Write the I/O Module PWM parameters to the drive.

Parameters

<i>pwm</i>	A structure that will be filled with the PWM I/O values
<i>info</i>	A structure containing additional information about the module.

Returns

A pointer to an error object, or NULL on success

The documentation for this class was generated from the following files:

- [CML_CopleyIO.h](#)
- [CopleyIO.cpp](#)
- [CopleyIOFile.cpp](#)

5.30 CopleyIOAnlg Struct Reference

This structure is used to return information about the analog inputs of a Copley I/O module.

Public Attributes

- [uint16 iRaw](#) [COPLEYIO_NUM_AIN]
Analog input raw value.
- [uint32 iScaled](#) [COPLEYIO_NUM_AIN]
Analog input scaled value.
- [uint32 iFactor](#) [COPLEYIO_NUM_AIN]
Analog input scaling factor.
- [uint32 iOffset](#) [COPLEYIO_NUM_AIN]
Analog input offset.
- [uint32 iUpLimit](#) [COPLEYIO_NUM_AIN]
Analog input upper limit for interrupt.
- [uint32 iLoLimit](#) [COPLEYIO_NUM_AIN]
Analog input lower limit for interrupt.
- [uint32 iAbsDelta](#) [COPLEYIO_NUM_AIN]
Analog input absolute delta value for interrupt.
- [uint32 iPosDelta](#) [COPLEYIO_NUM_AIN]
Analog input positive delta value for interrupt.

- [uint32 iNegDelta](#) [COPLEYIO_NUM_AIN]
Analog input negative delta value for interrupt.
- [uint16 iFlags](#) [COPLEYIO_NUM_AIN]
Analog input interrupt flags.
- [uint16 iMask](#) [COPLEYIO_NUM_AIN]
Analog input interrupt mask.

5.30.1 Detailed Description

This structure is used to return information about the analog inputs of a Copley I/O module.

The documentation for this struct was generated from the following file:

- [CML_CopleyIO.h](#)

5.31 CopleyIOCfg Struct Reference

IO Module configuration structure.

Collaboration diagram for CopleyIOCfg:

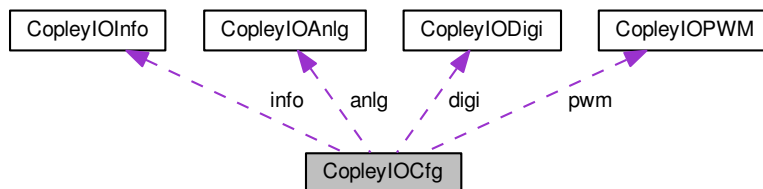

Public Attributes

- [CopleyIOInfo info](#)
Global IO Module parameters.
- [CopleyIODigi digi](#)
Digital IO parameters.
- [CopleyIOAnlg anlg](#)
Analog input parameters.
- [CopleyIOPWM pwm](#)
PWM output parameters.

5.31.1 Detailed Description

IO Module configuration structure.

This structure contains all user configurable parameters used by an IO module which may be stored in non-volatile memory.

The documentation for this struct was generated from the following file:

- [CML_CopleyIO.h](#)

5.32 CopleyIODigi Struct Reference

This structure is used to return information about the digital I/O of a Copley I/O module.

Public Attributes

- [uint16 bankMode](#) [COPLEYIO_DIO_BANKS]
Digital I/O bank mode.
- [uint16 pullupMsk](#) [COPLEYIO_DIO_BANKS]
Digital I/O pull-up resistor mask.
- [uint16 typeMsk](#) [COPLEYIO_DIO_BANKS]
Digital I/O output type mask.
- [uint16 faultMsk](#) [COPLEYIO_DIO_BANKS]
Digital I/O output fault state mask.
- [uint16 invMsk](#) [COPLEYIO_DIO_BANKS]
Digital I/O inversion mask.
- [uint16 valueMsk](#) [COPLEYIO_DIO_BANKS]
Digital I/O data value mask.
- [uint16 modeMsk](#) [COPLEYIO_DIO_BANKS]
Digital I/O output fault mode mask.
- [uint16 rawMsk](#) [COPLEYIO_DIO_BANKS]
Digital I/O raw data value mask.
- [uint16 hiLoMsk](#) [COPLEYIO_DIO_BANKS]
Digital I/O input low->high interrupt mask.
- [uint16 loHiMsk](#) [COPLEYIO_DIO_BANKS]
Digital I/O input high->low interrupt mask.
- [uint16 debounce0](#) [COPLEYIO_DIO_BANKS]
Digital I/O debounce time, bit 0.
- [uint16 debounce1](#) [COPLEYIO_DIO_BANKS]
Digital I/O debounce time, bit 1.
- [uint16 debounce2](#) [COPLEYIO_DIO_BANKS]
Digital I/O debounce time, bit 2.
- [uint16 debounce3](#) [COPLEYIO_DIO_BANKS]
Digital I/O debounce time, bit 3.
- [uint16 debounce4](#) [COPLEYIO_DIO_BANKS]
Digital I/O debounce time, bit 4.
- [uint16 debounce5](#) [COPLEYIO_DIO_BANKS]

Digital I/O debounce time, bit 5.

- [uint16 debounce6](#) [COPLEYIO_DIO_BANKS]

Digital I/O debounce time, bit 6.

- [uint16 debounce7](#) [COPLEYIO_DIO_BANKS]

Digital I/O debounce time, bit 7.

5.32.1 Detailed Description

This structure is used to return information about the digital I/O of a Copley I/O module.

The documentation for this struct was generated from the following file:

- [CML_CopleyIO.h](#)

5.33 CopleyIOInfo Struct Reference

IO Module characteristics data structure.

Public Attributes

- [uint32 serial](#)
Serial number.
- char [model](#) [COPLEYIO_MAX_STRING]
Model number string.
- char [mfgInfo](#) [COPLEYIO_MAX_STRING]
Amplifier's manufacturing information string.
- [uint16 hwType](#)
Hardware type code.
- [uint16 loopRate](#)
Main loop update rate (Hz)
- [uint16 fwVersion](#)
Firmware version number.
- [uint32 baud](#)
Serial port baud rate (bps)
- [uint16 maxWords](#)
Maximum number of words sent with any command.
- char [name](#) [COPLEYIO_MAX_STRING]
I/O module name.
- char [hostCfg](#) [COPLEYIO_MAX_STRING]
Host configuration state (CME use only)
- [int16 nodeCfg](#)
CAN node ID configuration.
- [uint16 rateCfg](#)
CAN bit rate configuration.
- [uint16 nodeID](#)
CAN node ID.

- [uint16 status](#)
CAN network status word.
- [uint16 rate](#)
CAN network bit rate.
- [uint16 anlgInt](#)
Active analog interrupts.
- [uint16 anlgIntEna](#)
Analog input global interrupt enable.
- [uint16 diglIntEna](#)
Digital input global interrupt enable.
- [uint32 pwmPeriodA](#)
PWM bank A period.
- [uint32 pwmPeriodB](#)
PWM bank B period.

5.33.1 Detailed Description

IO Module characteristics data structure.

This structure is used to hold information about the IO Module such as it's model number, serial number, etc.

Use the `IOModule::GetIOInfo` method to retrieve this information from the module.

The documentation for this struct was generated from the following file:

- [CML_CopleyIO.h](#)

5.34 CopleyIOPWM Struct Reference

This structure is used to return information about the PWM outputs of a Copley I/O module.

Public Attributes

- [uint16 oRaw](#) [COPLEYIO_NUM_PWM]
PWM output raw value.
- [uint32 oScaled](#) [COPLEYIO_NUM_PWM]
PWM output scaled value.
- [uint32 oFactor](#) [COPLEYIO_NUM_PWM]
PWM output scaling factor.
- [int32 oOffset](#) [COPLEYIO_NUM_PWM]
PWM output offset.

5.34.1 Detailed Description

This structure is used to return information about the PWM outputs of a Copley I/O module.

The documentation for this struct was generated from the following file:

- [CML_CopleyIO.h](#)

5.35 CopleyMotionLibrary Class Reference

Copley Motion Libraries utility object.

Public Member Functions

- [CopleyMotionLibrary](#) ()
Default constructor for the [CopleyMotionLibrary](#) object.
- [~CopleyMotionLibrary](#) ()
Destructor for [CopleyMotionLibrary](#) object.
- const char * [GetVersionString](#) ()
Get the CML library version string.
- void [SetDebugLevel](#) (CML_LOG_LEVEL level)
Set the debug message level.
- void [SetFlushLog](#) (bool flush)
Enable/Disable the flushing of the log file after each write.
- void [SetMaxLogSize](#) (int32 max)
Set the max CML log file size.
- void [FlushLog](#) (void)
Flush the log file (if one is open).
- void [SetLogFile](#) (const char *fname)
Set the debug message log file name.
- void [Debug](#) (const char *fmt,...)
Write a debug message to the log file.
- void [Warn](#) (const char *fmt,...)
Write a warning message to the log file.
- void [Error](#) (const char *fmt,...)
Write an error message to the log file.
- void [LogCAN](#) (bool recv, struct [CanFrame](#) &frame)
Write the CAN frame to the log file.
- CML_LOG_LEVEL [GetDebugLevel](#) (void)
Return the debug level.
- bool [GetFlushLog](#) (void)
Get the state of the log flushing setting.
- int32 [GetMaxLogSize](#) (void)
Return the max log size.
- const char * [GetLogFile](#) (void)
Return the name of the log file.

5.35.1 Detailed Description

Copley Motion Libraries utility object.

This object defines a number of handy methods related to the libraries as a whole.

A single global CML object is created by the libraries automatically.

5.35.2 Constructor & Destructor Documentation

5.35.2.1 `~CopleyMotionLibrary ()`

Destructor for [CopleyMotionLibrary](#) object.

This simply closes the log file if one is open.

5.35.3 Member Function Documentation

5.35.3.1 `void Debug (const char * fmt, ...)`

Write a debug message to the log file.

The debug level must be set \geq LOG_DEBUG for this message to be written.

Note that message logging is only available if file support is enabled in the [CML_Settings.h](#) file.

Parameters

<i>fmt</i>	A printf style format string
------------	------------------------------

5.35.3.2 `void Error (const char * fmt, ...)`

Write an error message to the log file.

The debug level must be set \geq LOG_ERRORS for this message to be written.

Note that message logging is only available if file support is enabled in the [CML_Settings.h](#) file.

Parameters

<i>fmt</i>	A printf style format string
------------	------------------------------

5.35.3.3 `void FlushLog (void)`

Flush the log file (if one is open).

This forces the log contents to be written to disk, thus preventing it from being lost if the program exits without calling the CML object destructor.

5.35.3.4 `CML_LOG_LEVEL GetDebugLevel (void) [inline]`

Return the debug level.

Returns

The debug level presently set

5.35.3.5 `bool GetFlushLog (void) [inline]`

Get the state of the log flushing setting.

Returns

true if enabled.

5.35.3.6 const char* GetLogFile (void) [inline]

Return the name of the log file.

Returns

The log file name as a zero terminated string

5.35.3.7 int32 GetMaxLogSize (void) [inline]

Return the max log size.

Returns

The max log size in bytes

5.35.3.8 const char * GetVersionString (void)

Get the CML library version string.

Returns

A string giving the CML version number

5.35.3.9 void LogCAN (bool *recv*, struct CanFrame & *frame*)

Write the CAN frame to the log file.

The log level must be at least LOG_FILT_CAN for this to be written.

Parameters

<i>recv</i>	True if this was a received message, false for transmit messages
<i>frame</i>	The frame to log

5.35.3.10 void SetDebugLevel (CML_LOG_LEVEL *level*)

Set the debug message level.

The library code includes some debug messages that may be enabled by setting the debug level to a value greater than LOG_NONE.

If the level was previously set higher than LOG_NONE, and is then set to LOG_NONE, any open log file will be closed.

The default log level is LOG_NONE (no messages).

Parameters

<i>level</i>	The log level.
--------------	----------------

5.35.3.11 void SetFlushLog (bool *flush*)

Enable/Disable the flushing of the log file after each write.

This can be useful if debug messages are being lost due to a crash, however it can increase the time necessary to write to the file.

The default is false (don't flush).

Parameters

<i>flush</i>	True if file flushing is desired
--------------	----------------------------------

5.35.3.12 void SetLogFile (const char * *fname*)

Set the debug message log file name.

This file will be used to log debug messages. The file will be created (or truncated if it already exists) when the first message is written to the file. Note that the debug level must be set > LOG_NONE for any messages to be written. Also note that file access must be enabled in [CML_Settings.h](#) for the log file to be used.

If the log file is already open when this method is called, it will be closed and a new log file with the specified name will be open on the next write to it.

The default log file name is "cml.log"

Parameters

<i>fname</i>	The log file name
--------------	-------------------

5.35.3.13 void SetMaxLogSize (int32 *max*)

Set the max CML log file size.

This option can be used to prevent a debug log file from getting so large it uses all available disk space on long runs. Once the log file exceeds this size, it will be renamed logfilename.bak (where logfilename is replaced by the log file name), and a new log file will be started. Any old backup log file will be overwritten.

The default max log size is 1,000,000 bytes.

Parameters

<i>max</i>	Maximum log file size in bytes
------------	--------------------------------

5.35.3.14 void Warn (const char * *fmt*, ...)

Write a warning message to the log file.

The debug level must be set >= LOG_WARNINGS for this message to be written.

Note that message logging is only available if file support is enabled in the [CML_Settings.h](#) file.

Parameters

<i>fmt</i>	A printf style format string
------------	------------------------------

The documentation for this class was generated from the following files:

- [CML.h](#)
- [CML.cpp](#)

5.36 CopleyNode Class Reference

Copley CANopen [Node](#) class.

Inheritance diagram for CopleyNode:

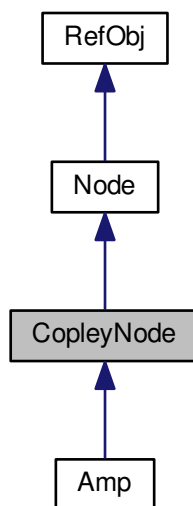

Collaboration diagram for CopleyNode:

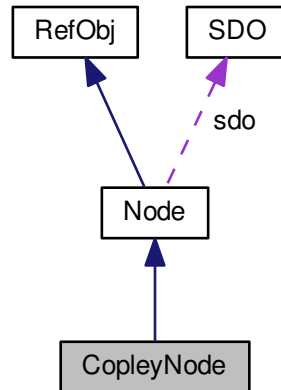

Public Member Functions

- `const Error * FirmwareUpdate (Firmware &fw)`
Use a special protocol to update the firmware in Copley CANopen devices.
- `const Error * SerialCmd (uint8 opcode, uint8 &ct, uint8 max=0, uint16 *data=0)`
Send a serial port message to a Copley device over the CANopen network.

Additional Inherited Members

5.36.1 Detailed Description

Copley CANopen [Node](#) class.

Objects of this class represent Copley products attached to the CANopen bus.

5.36.2 Member Function Documentation

5.36.2.1 `const Error * FirmwareUpdate (Firmware & fw)`

Use a special protocol to update the firmware in Copley CANopen devices.

Note that this is not part of normal operation, but rather a special utility function which allows the device firmware to be updated if necessary.

Only firmware files produced by Copley Controls Corp. should be used to update Copley devices. Attempting to update a device with incorrectly formatted firmware files will render it inoperable.

If an error occurs during the download of new firmware, it may be necessary to reprogram the device through its serial port. The CME-2 software can be used to recover an device in this case.

Parameters

<i>fw</i>	The firmware object holding the data to be programmed.
-----------	--

Returns

An error object, or NULL on success.

5.36.2.2 `const Error * SerialCmd (uint8 opcode, uint8 & ct, uint8 max = 0, uint16 * data = 0)`

Send a serial port message to a Copley device over the CANopen network.

Copley devices use serial ports for some basic configuration purposes. Most of the functions available over the serial interface are also available in the CANopen object dictionary, but not everything.

This function allows a native serial port command to be sent over the CANopen network. It allows any remaining features of the device to be accessed when only a CANopen connection is available.

Parameters

<i>opcode</i>	The command code to be sent to the amplifier.
<i>ct</i>	The number of 16-bit words of data to be sent to the amplifier. On return, this parameter will hold the number of 16-bit words of response data passed back from the amplifier.
<i>max</i>	The maximum number of words of response data that the data array can hold.
<i>data</i>	An array of data to be passed to the node with the command. On return, any response data (up to max words) will be passed here. If this parameter is not specified, then no data will be passed or returned regardless of the values passed in max and ct.

Returns

An error object, or null on success.

The documentation for this class was generated from the following files:

- [CML_Copley.h](#)
- [AmpFW.cpp](#)
- [CopleyNode.cpp](#)

5.37 CopleyNodeError Class Reference

This class represents errors that can be returned by the [CopleyNode](#) class.

Inheritance diagram for CopleyNodeError:

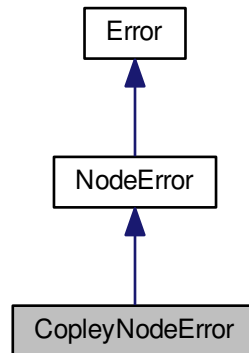

Collaboration diagram for CopleyNodeError:

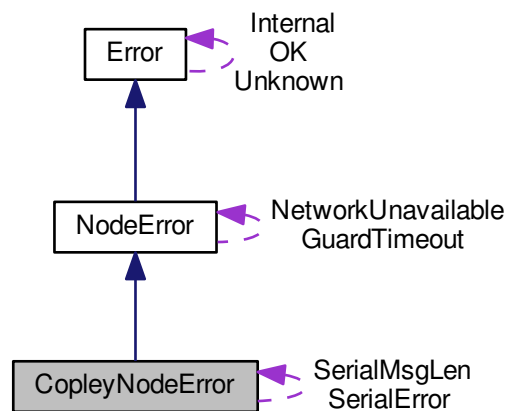

Static Public Attributes

- static const [CopleyNodeError SerialMsgLen](#)
Too much data passed for a serial port command.
- static const [CopleyNodeError SerialError](#)
The device return a serial port error code.

Protected Member Functions

- [CopleyNodeError](#) (uint16 id, const char *desc)
Standard protected constructor.

Additional Inherited Members

5.37.1 Detailed Description

This class represents errors that can be returned by the [CopleyNode](#) class.

There is one static member for each defined error.

The documentation for this class was generated from the following file:

- [CML_Copley.h](#)

5.38 CrntLoopConfig Struct Reference

This structure holds the current loop configuration parameters.

Public Member Functions

- [CrntLoopConfig](#) (void)
Default constructor.

Public Attributes

- [int16 kp](#)
Proportional gain.
- [int16 ki](#)
Integral gain.
- [int16 offset](#)
Current offset.
- [int16 peakLim](#)
Peak current limit (0.01 amp units) This is the maximum current that can be applied to the motor at any time Also used as Boost current in stepper mode.
- [int16 contLim](#)
Continuous current limit (0.01 amp units) This is the maximum current that can continuously be applied to the load.
- [int16 peakTime](#)
Time at peak current limit (milliseconds) If peak current is requested, it will fall back to the continuous limit within this amount of time.
- [uint16 stepHoldCurrent](#)
Stepper hold current (0.01 amps).
- [uint16 stepRun2HoldTime](#)
Run to hold time(milliseconds) The period of time, beginning when a move is complete, to when output current switched to hold current.
- [uint16 stepVolControlDelayTime](#)

Voltage control mode time delay (milliseconds) Time delay to enter into a special voltage control mode.

- [int32 slope](#)

Rate of change of current command (milliamps/sec).

5.38.1 Detailed Description

This structure holds the current loop configuration parameters.

The current loop is one of three servo control loops used by the amplifier to control a motor. The configuration parameters used by this control loop allow the servo performance to be 'tuned' for various motors and loads.

This structure also holds the parameters used to control current limiting. The current limiting acts on the commanded current before it is sent to the current loop.

The amplifier member functions [Amp::GetCrntLoopConfig](#) and [Amp::SetCrntLoopConfig](#) are used to read and write this data to the amplifier.

5.38.2 Constructor & Destructor Documentation

5.38.2.1 CrntLoopConfig (void) [inline]

Default constructor.

Simply initializes all members to zero.

5.38.3 Member Data Documentation

5.38.3.1 int16 contLim

Continuous current limit (0.01 amp units) This is the maximum current that can continuously be applied to the load.

Also used as Run current in stepper mode.

5.38.3.2 int16 peakTime

Time at peak current limit (milliseconds) If peak current is requested, it will fall back to the continuous limit within this amount of time.

Also used as Boost current time in stepper mode.

5.38.3.3 int32 slope

Rate of change of current command (milliamps/sec).

This parameter is only used when running in the low level programmed current mode (AMPMODE_PROG_CRNT), or in the CANopen profile torque mode (AMPMODE_CAN_TORQUE). In other modes this parameter is ignored and no limit is placed on the slope of the current command.

If this parameter is set to zero (default) it is not used in any mode of operation.

Note that this parameter is internally the same as the torque slope parameter which can be set using the function [Amp::SetTorqueSlope](#). The units are different however as this parameter controls slope in units of current and the torque slope function adjusts in units of torque.

5.38.3.4 uint16 stepHoldCurrent

Stepper hold current (0.01 amps).

Current used to hold the motor at rest. Used in stepper mode only.

5.38.3.5 uint16 stepRun2HoldTime

Run to hold time(milliseconds) The period of time, beginning when a move is complete, to when output current switched to hold current.

Used in stepper mode only.

5.38.3.6 uint16 stepVolControlDelayTime

Voltage control mode time delay (milliseconds) Time delay to enter into a special voltage control mode.

If set to zero this feature is disabled. Used for stepper mode only.

The documentation for this struct was generated from the following file:

- [CML_AmpStruct.h](#)

5.39 DAConfig Struct Reference

Configuration structure used to hold the settings for a drive's D/A converter.

Public Member Functions

- [DAConfig](#) (void)
Default constructor Initialize all elements to zero.

Public Attributes

- [int32 daConverterConfig](#)
D/A converter configuration.

5.39.1 Detailed Description

Configuration structure used to hold the settings for a drive's D/A converter.

These settings may be up/download from the amplifier using the functions [Amp::SetDAConverterConfig](#) and [Amp::GetDAConverterConfig](#)

5.39.2 Member Data Documentation

5.39.2.1 int32 daConverterConfig

D/A converter configuration.

This parameter sets the mode for the D/A converter on drives so equipped. See CAN ID 0x21E0 for details.

The documentation for this struct was generated from the following file:

- [CML_AmpStruct.h](#)

5.40 IOModule::DigInPDO Class Reference

Transmit [PDO](#) for mapping digital inputs.

Inheritance diagram for IOModule::DigInPDO:

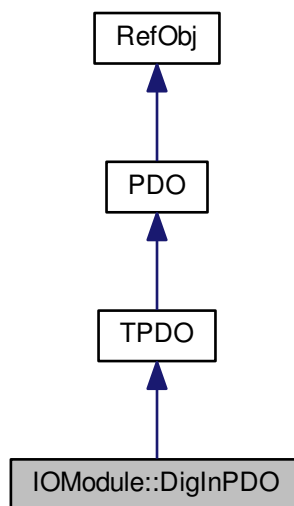

Collaboration diagram for IOModule::DigInPDO:

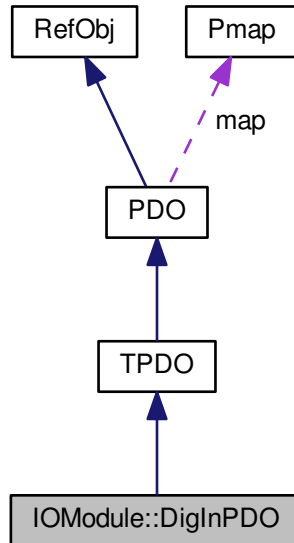

Public Member Functions

- const [Error](#) * [Init](#) (class [IOModule](#) *io, [uint32](#) cobID, [uint8](#) ct, [uint8](#) id[], [IOMODULE_EVENTS](#) event)
Initialize a digital input [PDO](#) object.
- bool [GetInVal](#) ([uint8](#) id, [uint8](#) &value)
Read the specified input bank from the [PDO](#)'s cached data.
- bool [GetBitVal](#) ([uint16](#) id, bool &value)
Update the locally stored value of one bit in this [PDO](#).
- void [Received](#) (void)
New transmit [PDO](#) received.

Additional Inherited Members

5.40.1 Detailed Description

Transmit [PDO](#) for mapping digital inputs.

This class represents the standard transmit [PDO](#) into which up to 64 digital inputs may be mapped.

5.40.2 Member Function Documentation

5.40.2.1 `bool GetBitVal (uint16 id, bool & value)`

Update the locally stored value of one bit in this [PDO](#).

Parameters

<i>id</i>	The output ID to be updated.
<i>value</i>	The new value for the output.

Returns

true if the value was updated, false if the output isn't mapped to this [PDO](#).

5.40.2.2 `bool GetInVal (uint8 id, uint8 & value)`

Read the specified input bank from the [PDO](#)'s cached data.

The value returned will be the last value received via [PDO](#) for this input bank.

Parameters

<i>id</i>	The input block ID to be checked.
<i>value</i>	The input value for the block will be returned here.

Returns

true if the value was returned, false if the block isn't mapped to this [PDO](#).

5.40.2.3 `const Error * Init (class IOModule * io, uint32 cobID, uint8 ct, uint8 id[], IOMODULE_EVENTS event)`

Initialize a digital input [PDO](#) object.

Parameters

<i>io</i>	Pointer to the I/O module to which this PDO is assigned.
<i>cobID</i>	The CAN ID for this PDO message.
<i>ct</i>	The number of input blocks to be mapped (1 to 8)
<i>id</i>	An array of ct input block ID numbers. These will be mapped (in order) to the PDO .
<i>event</i>	The event bit to post when a PDO message is received.

Returns

A pointer to an error object, or NULL on success

5.40.2.4 `void Received (void) [virtual]`

New transmit [PDO](#) received.

This method is called by the CANopen reader thread when a new [PDO](#) message is received. It causes this [PDO](#) object to post it's event to the [IOModule](#) object's event map. This will cause any waiting threads to wake up.

Reimplemented from [TPDO](#).

The documentation for this class was generated from the following files:

- [CML_IO.h](#)
- [IOModule.cpp](#)

5.41 IOModule::DigOutPDO Class Reference

Receive [PDO](#) for mapping digital output pins.

Inheritance diagram for IOModule::DigOutPDO:

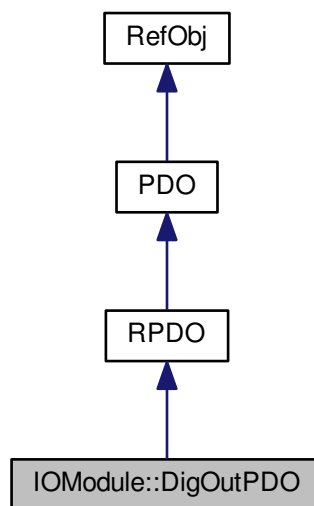

Collaboration diagram for IOModule::DigOutPDO:

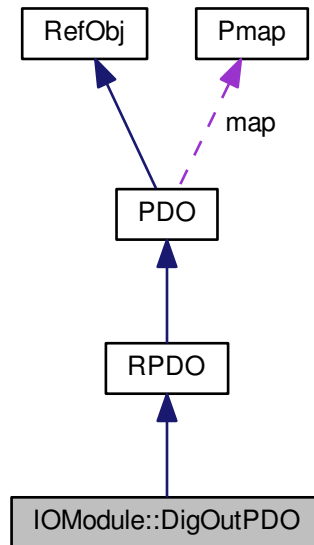

Public Member Functions

- const [Error](#) * [Init](#) (class [IOModule](#) *io, [uint32](#) cobID, [uint8](#) ct, [uint8](#) id[])
Initialize a digital output [PDO](#) object.
- bool [Update](#) ([uint8](#) id, [uint8](#) value)
Update the locally stored value of one of the 8-bit digital output blocks associated with this [PDO](#).
- bool [UpdateBit](#) ([uint16](#) id, bool value)
Update the locally stored value of one bit in this [PDO](#).
- const [Error](#) * [Transmit](#) (void)
Transmit this [PDO](#).

Additional Inherited Members

5.41.1 Detailed Description

Receive [PDO](#) for mapping digital output pins.

This class represents the standard receive [PDO](#) into which up to 64 digital output pins may be mapped.

5.41.2 Member Function Documentation

5.41.2.1 `const Error * Init (class IOModule * io, uint32 cobID, uint8 ct, uint8 id[])`

Initialize a digital output [PDO](#) object.

Parameters

<i>io</i>	Pointer to the I/O module to which this PDO is assigned.
<i>cobID</i>	The CAN ID for this PDO message.
<i>ct</i>	The number of output blocks to be mapped (1 to 8)
<i>id</i>	An array of <i>ct</i> output block ID numbers. These will be mapped (in order) to the PDO .

Returns

A pointer to an error object, or NULL on success

5.41.2.2 `const Error * Transmit (void)`

Transmit this [PDO](#).

Returns

A pointer to an error object, or NULL on success

5.41.2.3 `bool Update (uint8 id, uint8 value)`

Update the locally stored value of one of the 8-bit digital output blocks associated with this [PDO](#).

Parameters

<i>id</i>	The output block ID to be updated.
<i>value</i>	The new value for the output block.

Returns

true if the value was updated, false if the block isn't mapped to this [PDO](#).

5.41.2.4 `bool UpdateBit (uint16 id, bool value)`

Update the locally stored value of one bit in this [PDO](#).

Parameters

<i>id</i>	The output ID to be updated.
<i>value</i>	The new value for the output.

Returns

true if the value was updated, false if the output isn't mapped to this [PDO](#).

The documentation for this class was generated from the following files:

- [CML_IO.h](#)
- [IOModule.cpp](#)

5.42 EcatDgram Class Reference

Generic EtherCAT datagram class.

Inheritance diagram for EcatDgram:

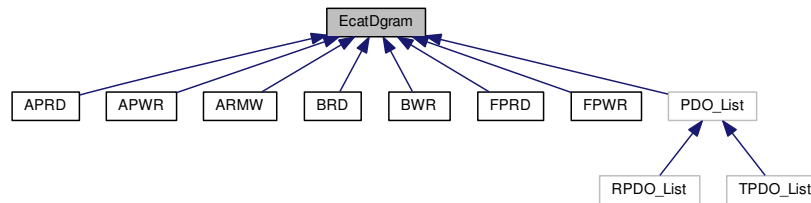

Public Member Functions

- [EcatDgram](#) (uint8 cmd, int16 adp, int16 ado, int16 len, void *ptr=0)
Construct a datagram with a variable data length.
- [EcatDgram](#) (uint8 cmd, int16 adp, int16 ado, int16 len, int32 val)
Construct a datagram with up to 4 bytes of data.
- virtual [~EcatDgram](#) ()
Default destructor for an EtherCAT datagram.
- void [Init](#) (uint8 cmd, int16 adp, int16 ado, int16 len, int32 val)
Initialize a datagram with up to 4 bytes of data.
- void [Init](#) (uint8 cmd, int16 adp, int16 ado, int16 len, void *ptr=0)
Initialize a datagram with an arbitrary amount of data.
- void [Reset](#) (void)
Reset the datagram.
- void [setNext](#) (EcatDgram *n)
Add a new datagram after this one.
- [EcatDgram *](#) [getNext](#) (void)
Get a pointer to the next datagram stored in the frame.
- virtual const [Error *](#) [Load](#) (void *buff, int16 &off)
Pack this datagram into a memory buffer that's large enough to hold an entire EtherCAT frame.
- bool [checkNdx](#) (void)
Compare the index stored in the frame that this datagram is part of to the expected value.
- void [setData](#) (void *ptr)
Update the data value stored in this datagram.
- void [setData](#) (int32 val)
Update the data value stored in this datagram.
- void [setNdx](#) (uint8 ndx)
Update the index value associated with this datagram.
- uint8 [getNdx](#) (void)
Return the current datagram index value.
- int16 [getDgramLen](#) (void)
Return the datagram length in bytes.

5.42.1 Detailed Description

Generic [EtherCAT](#) datagram class.

At the lowest levels, an [EtherCAT](#) packet is made up of one or more reads and/or writes to memory locations on the slave nodes. Each of these memory accesses is called a datagram.

There are several different types of datagrams; reads/writes to a node based on it's location in the network, reads/writes to a node based on it's address, broadcast accesses to all nodes on the network, etc.

This class makes up the base for all datagrams.

In general, CML uses don't need to concern themselves with [EtherCAT](#) datagrams. This class is used internally in the library to support low level communications over the [EtherCAT](#) network.

5.42.2 Constructor & Destructor Documentation

5.42.2.1 `EcatDgram (uint8 cmd, int16 adp, int16 ado, int16 len, void * ptr = 0)`

Construct a datagram with a variable data length.

Parameters

<i>cmd</i>	Identifies the type of datagram
<i>adp</i>	Generally the EtherCAT node on the network
<i>ado</i>	Generally identifies the memory address being accessed.
<i>len</i>	Length of the memory access in bytes
<i>ptr</i>	Pointer where the read/write data is held

5.42.2.2 `EcatDgram (uint8 cmd, int16 adp, int16 ado, int16 len, int32 val)`

Construct a datagram with up to 4 bytes of data.

Parameters

<i>cmd</i>	Identifies the type of datagram
<i>adp</i>	Generally the EtherCAT node on the network
<i>ado</i>	Generally identifies the memory address being accessed.
<i>len</i>	Length of the memory access in bytes (up to 4)
<i>val</i>	Value of the data to send.

5.42.3 Member Function Documentation

5.42.3.1 `bool checkNdx (void)`

Compare the index stored in the frame that this datagram is part of to the expected value.

This can be used to help verify that the frame received over the [EtherCAT](#) network contains the expected datagrams.

Returns

true if the index stored in the frame holds the expected value.

5.42.3.2 int16 getDgramLen (void)

Return the datagram length in bytes.

That's the length of the data plus the 12 byte header.

Returns

The datagram length in bytes.

5.42.3.3 uint8 getNdx (void)

Return the current datagram index value.

Returns

The current index value.

5.42.3.4 EcatDgram * getNext (void)

Get a pointer to the next datagram stored in the frame.

Returns

A pointer to the next datagram, or NULL if there is none.

5.42.3.5 void Init (uint8 cmd, int16 adp, int16 ado, int16 len, int32 val)

Initialize a datagram with up to 4 bytes of data.

The data value will be stored in a local buffer

Parameters

<i>cmd</i>	Identifies the type of datagram
<i>adp</i>	Generally the EtherCAT node on the network
<i>ado</i>	Generally identifies the memory address being accessed.
<i>len</i>	Length of the memory access in bytes (up to 4)
<i>val</i>	Value of the data to send.

5.42.3.6 void Init (uint8 cmd, int16 adp, int16 ado, int16 len, void * ptr = 0)

Initialize a datagram with an arbitrary amount of data.

Parameters

<i>cmd</i>	Identifies the type of datagram
<i>adp</i>	Generally the EtherCAT node on the network

<i>ado</i>	Generally identifies the memory address being accessed.
<i>len</i>	Length of the memory access in bytes
<i>ptr</i>	Pointer where the read/write data is held

5.42.3.7 `const Error * Load (void * ptr, int16 & off) [virtual]`

Pack this datagram into a memory buffer that's large enough to hold an entire [EtherCAT](#) frame.

Parameters

<i>ptr</i>	Points to the frame buffer
<i>off</i>	Gives the offset in the frame where this datagram should be loaded. On return, this is increased by the size of the datagram

Returns

An error code or null on success.

5.42.3.8 `void setData (void * ptr)`

Update the data value stored in this datagram.

Parameters

<i>ptr</i>	Pointer to the data to store. The data referenced by this pointer should be at least as long as the length of the datagram.
------------	---

5.42.3.9 `void setData (int32 val)`

Update the data value stored in this datagram.

Parameters

<i>val</i>	The value to be stored in the datagram. The datagram is expected to be no longer than 4 bytes.
------------	--

5.42.3.10 `void setNdx (uint8 ndx)`

Update the index value associated with this datagram.

Parameters

<i>ndx</i>	The new index value to store.
------------	-------------------------------

5.42.3.11 `void setNext (EcatDgram * n)`

Add a new datagram after this one.

Parameters

<i>n</i>	Pointer to the next datagram. A local copy of this pointer will be stored
----------	---

The documentation for this class was generated from the following files:

- [CML_EtherCAT.h](#)
- [EtherCAT.cpp](#)

5.43 EcatFrame Class Reference

[EtherCAT](#) frame class.

Inheritance diagram for EcatFrame:

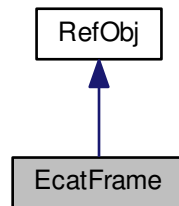

Collaboration diagram for EcatFrame:

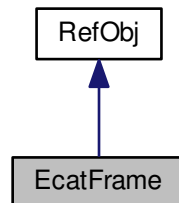

Additional Inherited Members

5.43.1 Detailed Description

[EtherCAT](#) frame class.

This is used internally to represent a single frame of data sent over the [EtherCAT](#) network. The frame consists of a header structure followed by a series of datagrams.

The documentation for this class was generated from the following files:

- [CML_EtherCAT.h](#)

- [EtherCAT.cpp](#)

5.44 Error Class Reference

This class is the root class for all error codes returned by functions defined within the Motion Library.

Inheritance diagram for Error:

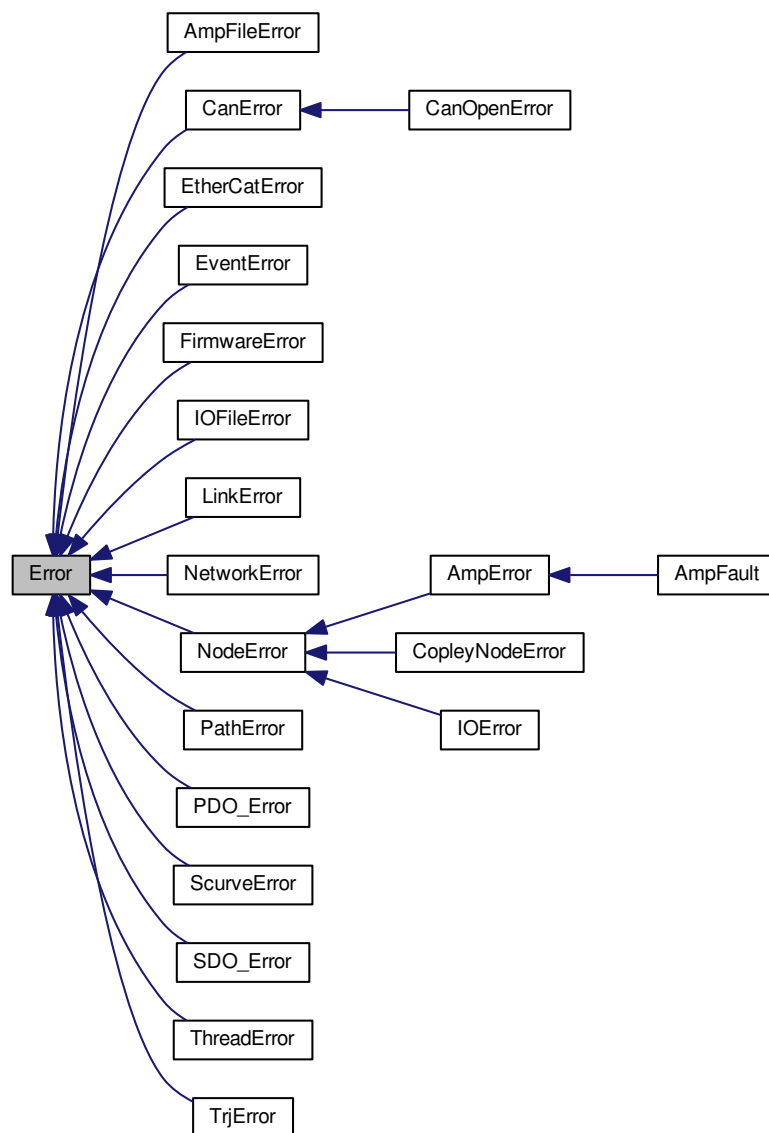

Collaboration diagram for Error:

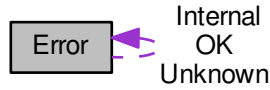

Public Member Functions

- `const char * toString () const`
Return a C style string describing the error condition represented by this error object.
- `uint16 GetID (void) const`
Return an integer ID that can be used to identify the error.

Static Public Member Functions

- `static const Error * Lookup (int16 id)`
Lookup the constant error object associated with the passed ID code.

Static Public Attributes

- `static const Error OK`
A constant error object that represents no error.
- `static const Error Unknown`
An invalid error ID code was passed to `Error::Lookup`.
- `static const Error Internal`
Generic internal software error.

Protected Member Functions

- `Error (uint16 i, const char *desc)`
Constructor used to create an error object of a particular type.

5.44.1 Detailed Description

This class is the root class for all error codes returned by functions defined within the Motion Library.

Every error condition defined in the library has a constant, static error object associated with it. Pointers to these objects are returned from the various function calls.

All library functions that return an error object pointer will return a NULL pointer in the case of no error. This allows one to simply test the error pointer returned to determine if it indicates an error.

For example:

```

const Error *err = SomeFunctionCall();

if( err )
    printf( "Error: %s\n", err->toString() );
else
    printf( "no error\n" );

```

To test for a specific error condition, the following code can be used:

```

const Error *err = SomeFunctionCall();

if( err == &ThreadError::Timeout )
    printf( "A timeout occurred\n" );

```

Note that the constructor used to create a new unique error code is protected, therefore only sub-classes of the `Error` object are allowed to create new unique error codes.

5.44.2 Constructor & Destructor Documentation

5.44.2.1 `Error(uint16 i, const char * desc)` `[inline]`, `[protected]`

Constructor used to create an error object of a particular type.

This constructor is protected, so only sub-classes of the `Error` class can construct objects in this manner.

A unique ID coded and a description string must be provided with the new object.

Parameters

<i>i</i>	The unique error ID value
<i>desc</i>	A description of the error

5.44.3 Member Function Documentation

5.44.3.1 `uint16 GetID(void) const` `[inline]`

Return an integer ID that can be used to identify the error.

Each error code in the system has a unique 16-bit integer identifier associated with it. This function can be used to return this identifier.

These ID codes are primarily intended for internal use by the `Error` object, they are only provided externally for use in system which require an integer error ID code to interface with other parts of the system. The function `Error::Lookup` can be used to convert the ID value back into an error object.

Returns

The 16-bit integer ID value associated with this `Error` object.

5.44.3.2 `const Error * Lookup(int16 id)` `[static]`

Lookup the constant error object associated with the passed ID code.

If the passed ID doesn't correspond to any known `Error` object, then the address of the `Error::Unknown` will be returned.

Parameters

<i>id</i>	The ID code of the error to be found
-----------	--------------------------------------

Returns

A pointer to an error object.

5.44.3.3 `const char* toString () const [inline]`

Return a C style string describing the error condition represented by this error object.

Returns

A constant character string describing the error condition.

The documentation for this class was generated from the following files:

- [CML_Error.h](#)
- [Error.cpp](#)

5.45 EtherCAT Class Reference

The [EtherCAT](#) class is the top level interface into the [EtherCAT](#) network.

Inheritance diagram for EtherCAT:

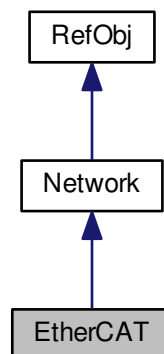

Collaboration diagram for EtherCAT:

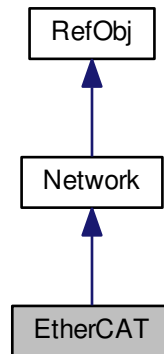

Public Member Functions

- [NetworkType](#) [GetNetworkType](#) (void)
Return the network type.
- const [Error](#) * [GetIdFromEEPROM](#) (Node *n, struct [NodeIdentity](#) &id)
Read the node ID info that was pulled from EEPROM on startup.
- const [Error](#) * [SetNodeGuard](#) (Node *n, [GuardProtocol](#) type, Timeout timeout=200, [uint8](#) life=0)
Configure the heartbeat protocol for an [EtherCAT](#) node.
- const [Error](#) * [SetSync0Period](#) (Node *n, [uint32](#) ns)
Set the period of the SYNC0 signal used on nodes with a distributed clock.
- [uint16](#) [getNodeCount](#) (void)
Return the number of nodes discovered on the network.
- const [Error](#) * [GetNodeAddress](#) (Node *n, [uint16](#) &addr)
Return the [EtherCAT](#) address assigned to this node.
- const [Error](#) * [FoE_DnldStart](#) (Node *n, const char *filename, [uint32](#) password, Timeout to=2000)
Initiate a new file download using the File over [EtherCAT](#) (FoE) protocol.
- const [Error](#) * [FoE_DnldData](#) (Node *n, [int32](#) len, [uint8](#) *buff, Timeout to=2000, bool end=true)
Download a block of file data to a node using the File over [EtherCAT](#) (FoE) protocol.
- const [Error](#) * [FoE_UpldStart](#) (Node *n, const char *filename, [uint32](#) password, Timeout to=2000)
Initiate a new file upload using the File over [EtherCAT](#) (FoE) protocol.
- const [Error](#) * [FoE_UpldData](#) (Node *n, [int32](#) max, [int32](#) *len, [uint8](#) *data, Timeout to=2000)
Upload a block of file data from a node using the File over [EtherCAT](#) (FoE) protocol.
- [int32](#) [FoE_LastErrInfo](#) (Node *n, char *msg, int maxMsg)
Return the detailed error code and message for the most recent FoE error response on this node.
- [int32](#) [maxSdoToNode](#) (Node *n)
Return the maximum number of bytes that can be sent in an [SDO](#) message.
- [int32](#) [maxSdoFromNode](#) (Node *n)
Return the maximum number of bytes that can be received in an [SDO](#) message.

- const [Error](#) * [WaitCycleUpdate](#) (Timeout to)
Wait for the cyclic thread to update.

Protected Member Functions

- const [Error](#) * [InitDistClk](#) (void)
Initialize the distributed clock system on this network.
- const [Error](#) * [MailboxTransfer](#) ([Node](#) *n, [uint16](#) len, [uint16](#) *ret, Timeout timeout=2000)
Write a block of data to the mailbox of an [EtherCAT](#) node and wait for a response.
- const [Error](#) * [AddToFrame](#) (class [EcatFrame](#) *frame, class [EcatDgram](#) *dg)
Add a datagram to the frame.

Friends

- class [Linkage](#)
- class [Node](#)

Additional Inherited Members

5.45.1 Detailed Description

The [EtherCAT](#) class is the top level interface into the [EtherCAT](#) network.

There should be at least one object of this class in every [EtherCAT](#) based application.

5.45.2 Member Function Documentation

5.45.2.1 const [Error](#) * [AddToFrame](#) (class [EcatFrame](#) * *frame*, class [EcatDgram](#) * *dg*) [protected]

Add a datagram to the frame.

If the frame is too large to add the datagram, then first send the frame, reset it and add the datagram.

Parameters

<i>frame</i>	The frame
<i>dg</i>	The datagram

Returns

An error pointer or NULL on success

5.45.2.2 const [Error](#) * [FoE_DnldData](#) ([Node](#) * *n*, [int32](#) *len*, [uint8](#) * *data*, Timeout *to* = 2000, bool *end* = true)

Download a block of file data to a node using the File over [EtherCAT](#) (FoE) protocol.

The transfer should have been previously initialized by calling the [EtherCAT::FoE_DnldStart](#) function.

Parameters

<i>n</i>	Pointer to the node to download to
<i>len</i>	Length of data to download in bytes
<i>data</i>	Buffer holding the data to download
<i>to</i>	A timeout value.
<i>end</i>	True if this is the last block of data to be sent

Returns

An error pointer on failure, or null on success.

5.45.2.3 `const Error * FoE_DnldStart (Node * n, const char * filename, uint32 password, Timeout to = 2000)`

Initiate a new file download using the File over [EtherCAT](#) (FoE) protocol.

This function should be used to start a new file download. On success, the [EtherCAT::FoE_DnldData](#) function can be used to pass the file data.

Parameters

<i>n</i>	Points to the node who will receive this download
<i>filename</i>	Name of the file to be sent. May be null if no file name is to be passed.
<i>password</i>	Optional password value to be sent to the slave device (0 if not used)
<i>to</i>	Timeout to wait for response.

Returns

An error pointer on failure, or null on success.

5.45.2.4 `int32 FoE_LastErrInfo (Node * n, char * msg, int maxMsg)`

Return the detailed error code and message for the most recent FoE error response on this node.

Parameters

<i>n</i>	Points to the node in question
<i>msg</i>	Buffer where error message should be stored (can be null)
<i>maxMsg</i>	Size of the message buffer

Returns

The most recent error code returned by this node.

5.45.2.5 `const Error * FoE_UpldData (Node * n, int32 max, int32 * len, uint8 * data, Timeout to = 2000)`

Upload a block of file data from a node using the File over [EtherCAT](#) (FoE) protocol.

The transfer should have been previously initialized by calling the [EtherCAT::FoE_UpldStart](#) function.

Parameters

<i>n</i>	Pointer to the node to upload from
<i>max</i>	Maximum length of data to upload in bytes
<i>len</i>	On return, holds the actual number of bytes uploaded.
<i>data</i>	Buffer where data will be written
<i>to</i>	A timeout value.

Returns

An error pointer on failure, or null on success.

5.45.2.6 `const Error * FoE_UpldStart (Node * n, const char * filename, uint32 password, Timeout to = 2000)`

Initiate a new file upload using the File over [EtherCAT](#) (FoE) protocol.

This function should be used to start a new file upload. On success, the [EtherCAT::FoE_UpldData](#) function can be used to read the file data.

Parameters

<i>n</i>	Points to the node from which the data will be uploaded.
<i>filename</i>	Name of the file to be read. May be null if no file name is to be passed.
<i>password</i>	Optional password value to be sent to the slave device (0 if not used)
<i>to</i>	Timeout to wait for response.

Returns

An error pointer on failure, or null on success.

5.45.2.7 `const Error * GetIdFromEEPROM (Node * n, struct NodeIdentity & id)`

Read the node ID info that was pulled from EEPROM on startup.

This can be useful on nodes that don't support the CoE protocol and therefore can't use the more standard [Node::GetIdentity](#) method.

Parameters

<i>n</i>	Points to the node to access
<i>id</i>	Structure where identity info will be returned

Returns

An error pointer on failure, or null on success.

5.45.2.8 `NetworkType GetNetworkType (void) [inline],[virtual]`

Return the network type.

Returns

Always returns the value `NET_TYPE_ETHERCAT`

Implements [Network](#).

5.45.2.9 `const Error * GetNodeAddress (Node * n, uint16 & addr)`

Return the [EtherCAT](#) address assigned to this node.

When each node is added to an [EtherCAT](#) network, the network object assigns it a unique address. This address is then used by the master to communicate with the node over the network.

Parameters

<i>n</i>	Pointer to the node object
<i>addr</i>	The assigned address will be returned here

Returns

An error pointer on failure, or null on success.

5.45.2.10 `uint16 getNodeCount (void) [inline]`

Return the number of nodes discovered on the network.

Returns

The number of nodes on the [EtherCAT](#) network

5.45.2.11 `const Error * InitDistClk (void) [protected]`

Initialize the distributed clock system on this network.

This is called at startup by `EtherCAT::Open()`;

Returns

An error object, or NULL on success

5.45.2.12 `const Error * MailboxTransfer (Node * n, uint16 len, uint16 * ret, Timeout timeout = 2000) [protected]`

Write a block of data to the mailbox of an [EtherCAT](#) node and wait for a response.

Note that the mailbox mutex should be held when this is called.

Parameters

<i>n</i>	The node to access.
<i>len</i>	The number of bytes of data to send
<i>ret</i>	returns the actual number of bytes returned.
<i>timeout</i>	The maximum time to wait for a response.

Returns

An error pointer on failure, or null on success.

5.45.2.13 `int32 maxSdoFromNode (Node * n) [virtual]`

Return the maximum number of bytes that can be received in an [SDO](#) message.

For [CANopen](#) this is always 8 (the max size of a CAN frame). For [EtherCAT](#) it's the size of the mailbox buffer, and is node specific

Parameters

<i>n</i>	The node to query
----------	-------------------

Returns

The maximum number of bytes in an [SDO](#) receive message

Reimplemented from [Network](#).

5.45.2.14 `int32 maxSdoToNode (Node * n) [virtual]`

Return the maximum number of bytes that can be sent in an [SDO](#) message.

For CANopen this is always 8 (the max size of a CAN frame). For [EtherCAT](#) it's the size of the mailbox buffer, and is node specific

Parameters

<i>n</i>	The node to query
----------	-------------------

Returns

The maximum number of bytes in an [SDO](#) transmit message

Reimplemented from [Network](#).

5.45.2.15 `const Error * SetNodeGuard (Node * n, GuardProtocol type, Timeout timeout = 200, uint8 life = 0) [virtual]`

Configure the heartbeat protocol for an [EtherCAT](#) node.

This sets the heartbeat timeout used for process data on the [EtherCAT](#) node.

Parameters

<i>n</i>	The node to configure heartbeat on
<i>type</i>	The type of node guarding to configure.
<i>timeout</i>	A timeout (milliseconds) to use for this node guarding protocol. If not specified, this parameter defaults to 200 milliseconds.
<i>life</i>	This parameter is not used under EtherCAT .

Returns

An error object, or NULL on success

Implements [Network](#).

5.45.2.16 `const Error * SetSync0Period (Node * n, uint32 ns)`

Set the period of the SYNC0 signal used on nodes with a distributed clock.

This also starts generation of the SYNC0 signal.

Parameters

<i>n</i>	The node to modify
<i>ns</i>	The period in nanoseconds.

Returns

An error object, or NULL on success

5.45.2.17 `const Error * WaitCycleUpdate (Timeout to)`

Wait for the cyclic thread to update.

Parameters

<i>to</i>	Max time to wait before returning an error
-----------	--

Returns

An error object on failure, or NULL on success.

The documentation for this class was generated from the following files:

- [CML_EtherCAT.h](#)
- [ecatdc.cpp](#)
- [EtherCAT.cpp](#)

5.46 EtherCatError Class Reference

This class holds the error codes that describe [EtherCAT](#) error conditions.

Inheritance diagram for EtherCatError:

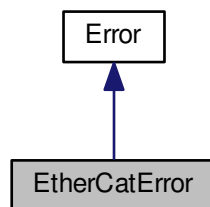

Collaboration diagram for EtherCatError:

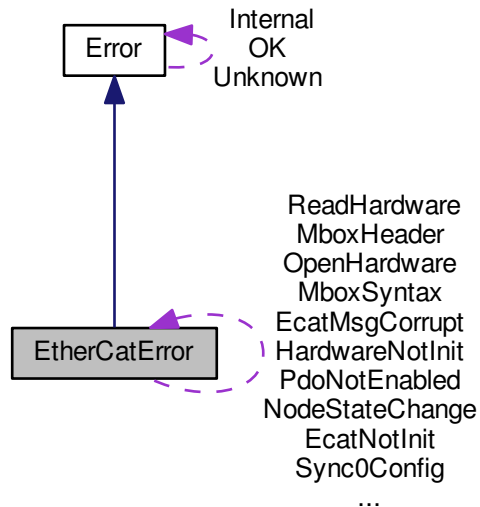

Static Public Attributes

- static const [EtherCatError ThreadStart](#)
Unable to start main EtherCAT.
- static const [EtherCatError HardwareNotInit](#)
EtherCAT hardware has not been initialized.
- static const [EtherCatError OpenHardware](#)
Unable to open EtherCAT hardware.
- static const [EtherCatError ReadHardware](#)
Error reading from Ethernet socket.
- static const [EtherCatError WriteHardware](#)
Error writing to Ethernet socket.
- static const [EtherCatError NoResponse](#)
Remote device did not respond to request (working counter is zero).
- static const [EtherCatError EcatNotInit](#)
EtherCAT network object not initialized.
- static const [EtherCatError NodeNotFound](#)
Specified node was not found on the EtherCAT network.
- static const [EtherCatError NodeBootMode](#)
EtherCAT node is currently in boot mode.
- static const [EtherCatError NodeStateChange](#)
Error changing node operational state.
- static const [EtherCatError EcatMsgCorrupt](#)

- EtherCAT message received from network is corrupt.*

 - static const [EtherCatError DatagramWontFit](#)
Not enough space in frame for new datagram.
 - static const [EtherCatError MboxError](#)
EtherCAT node returned an unknown mailbox error code.
 - static const [EtherCatError MboxSyntax](#)
EtherCAT node reported the syntax of mailbox header is invalid.
 - static const [EtherCatError MboxProtocol](#)
EtherCAT node does not support the requested mailbox protocol.
 - static const [EtherCatError MboxChannel](#)
EtherCAT node returned an invalide mailbox channel code.
 - static const [EtherCatError MboxService](#)
EtherCAT node does not support the requested mailbox service.
 - static const [EtherCatError MboxHeader](#)
EtherCAT node reported an invalid mailbox protocol header.
 - static const [EtherCatError MboxTooShort](#)
EtherCAT node reported the length of the mailbox data is too short.
 - static const [EtherCatError MboxMemory](#)
EtherCAT node reported insufficient memory for mailbox transfer.
 - static const [EtherCatError MboxSize](#)
EtherCAT node reported inconsistent mailbox data length.
 - static const [EtherCatError FoEformat](#)
EtherCAT node returned incorrectly formatted FoE response.
 - static const [EtherCatError FoError](#)
EtherCAT node returned an FoE error response.
 - static const [EtherCatError NodeNotInit](#)
EtherCAT node has not been initialized.
 - static const [EtherCatError PdoNotEnabled](#)
PDO is not currently enabled on network.
 - static const [EtherCatError NetworkWiringError](#)
EtherCAT network is not correctly wired.
 - static const [EtherCatError Sync0Config](#)
Error configuring SYNC0 timer on slave device.

Additional Inherited Members

5.46.1 Detailed Description

This class holds the error codes that describe [EtherCAT](#) error conditions.

The documentation for this class was generated from the following file:

- [CML_EtherCAT.h](#)

5.47 EtherCatHardware Class Reference

Low level Ethernet hardware interface.

Inheritance diagram for EtherCatHardware:

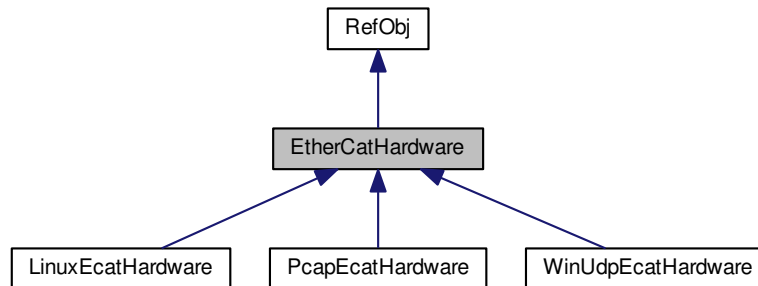

Collaboration diagram for EtherCatHardware:

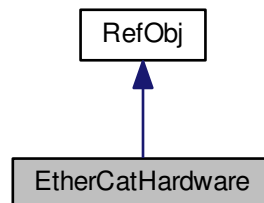

Additional Inherited Members

5.47.1 Detailed Description

Low level Ethernet hardware interface.

This pure virtual class is the base for an OS specific class which implements the interface to the Ethernet hardware.

The documentation for this class was generated from the following file:

- [CML_EtherCAT.h](#)

5.48 EtherCatSettings Class Reference

Configuration object used to customize global settings for the [EtherCAT](#) network.

Public Member Functions

- [EtherCatSettings](#) ()
Default constructor for [EtherCatSettings](#) object.

Public Attributes

- int [readThreadPriority](#)
Defines the [EtherCAT](#) read thread priority.
- int [cycleThreadPriority](#)
Defines the [EtherCAT](#) cycle thread priority.
- Timeout [cyclePeriod](#)
[EtherCAT](#) cycle period.

5.48.1 Detailed Description

Configuration object used to customize global settings for the [EtherCAT](#) network.

An object of this type may be passed to the `EtherCAT::Open()` method when the network is first opened.

If no settings object is passed to the `EtherCAT::Open()` method, then the behavior is exactly the same as passing a [EtherCatSettings](#) object with the default settings.

5.48.2 Constructor & Destructor Documentation

5.48.2.1 `EtherCatSettings()` `[inline]`

Default constructor for [EtherCatSettings](#) object.

This sets all settings to their default values

5.48.3 Member Data Documentation

5.48.3.1 Timeout `cyclePeriod`

[EtherCAT](#) cycle period.

This parameter defines the update rate at which the [EtherCAT](#) network is polled. Default: 1 ms.

5.48.3.2 int `cycleThreadPriority`

Defines the [EtherCAT](#) cycle thread priority.

The cycle thread is started when the [EtherCAT](#) object is first opened (using `EtherCAT::Open()`). This thread is responsible for polling the [EtherCAT](#) network at a set frequency. It should be run at a relatively high priority. Default: 9

5.48.3.3 int readThreadPriority

Defines the [EtherCAT](#) read thread priority.

The read thread is started when the [EtherCAT](#) object is first opened (using `EtherCAT::Open()`). This thread is responsible for reading Ethernet messages from the hardware and processing them as they arrive. It should be run at a relatively high priority. Default: 9

The documentation for this class was generated from the following file:

- [CML_EtherCAT.h](#)

5.49 Event Class Reference

Events are a generic mechanism used to wait on some condition.

Inheritance diagram for Event:

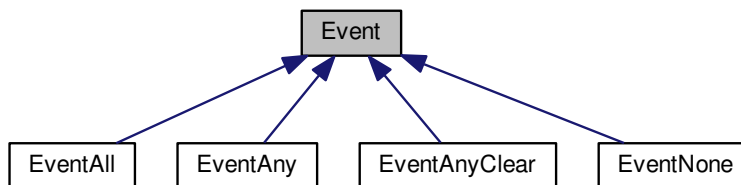

Public Member Functions

- [Event](#) (uint32 val=0)
Default constructor for an [Event](#) object.
- virtual [~Event](#) ()
[Event](#) destructor.
- [Event](#) (const [Event](#) &)
[Event](#) object copy constructor.
- [Event](#) & [operator=](#) (const [Event](#) &)
[Event](#) assignment operator.
- const [Error](#) * [setValue](#) (uint32 val)
Change the value that the event will wait for.
- void [setChain](#) (class [EventMap](#) &map, uint32 mask)
Setup event chaining.
- void [delChain](#) (void)
Remove any pointer to a chained event map.
- uint32 [getValue](#) (void)
Return the value that this event will wait on.
- uint32 [getMask](#) (void)

Return the most recent mask value that caused the event to succeed.

- const `Error * Wait (EventMap &m, Timeout timeout)`

Wait on an event.

- virtual bool `isTrue (uint32 mask)`

Test the event to see if it's condition is true.

Protected Attributes

- `uint32 value`

This is the value that the event is waiting for.

Friends

- class `EventMap`

5.49.1 Detailed Description

Events are a generic mechanism used to wait on some condition.

They are used in conjunction with the `EventMap` object.

Every `EventMap` object has a 32-bit mask register which describes it's state. `Event` objects may be attached to an `EventMap` to wait for any combination of bits in the mask to become active.

The base `Event` class is a virtual class, and therefore shouldn't be used directly. It is extended by a number of sub-classes which are used to wait for certain map bits to be set, cleared, etc.

An `Event` object may only be assigned to one `EventMap` at a time. An attempt to attach it to multiple `EventMap` objects will result in an error. Further, `Event` objects are not thread safe. Only one thread should access a particular `Event` object at a time. `EventMap` objects however are thread safe, so any number of threads may attach their own `Event` objects to the same `EventMap` object without issue.

5.49.2 Constructor & Destructor Documentation

5.49.2.1 `Event (uint32 val = 0)`

Default constructor for an `Event` object.

Parameters

<code>val</code>	The value that the event will wait for. If not specified, defaults to zero.
------------------	---

5.49.2.2 `~Event (void) [virtual]`

`Event` destructor.

This makes sure the event isn't mapped when it's destroyed

5.49.2.3 `Event (const Event & e)`

`Event` object copy constructor.

Parameters

<i>e</i>	Another event that this will copy.
----------	------------------------------------

5.49.3 Member Function Documentation

5.49.3.1 void delChain (void)

Remove any pointer to a chained event map.

This undoes any chaining that was setup using the [Event::setChain](#) method.

5.49.3.2 uint32 getMask (void) [inline]

Return the most recent mask value that caused the event to succeed.

After a successful Wait, this can be used to return the mask that caused the successful match.

Returns

The mask value

5.49.3.3 uint32 getValue (void) [inline]

Return the value that this event will wait on.

Returns

The event value

5.49.3.4 virtual bool isTrue (uint32 mask) [inline],[virtual]

Test the event to see if it's condition is true.

This method should be implemented in the sub-class to define the type of event matching used. The base class always returns false.

Parameters

<i>mask</i>	The EventMap mask compare to.
-------------	---

Returns

true if the event is satisfied, false if not.

Reimplemented in [EventNone](#), [EventAll](#), [EventAnyClear](#), and [EventAny](#).

5.49.3.5 Event & operator= (const Event & e)

[Event](#) assignment operator.

This uses the value of the passed event object to update this event's value. Note that it's not legal to change an events value while the event is attached to an [EventMap](#) object. If this is attempted, then this assignment will silently fail. The preferred method for changing an event's value is through the [Event::setValue](#) method.

Parameters

<i>e</i>	Another event that will be used to initialize this one.
----------	---

Returns

A reference to this object

5.49.3.6 void setChain (class EventMap & map, uint32 mask)

Setup event chaining.

Each time the event is updated, it will either set or clear the bits specified by mask in the referenced [EventMap](#) object. The bits will be set if the update causes the event to be true, and cleared otherwise.

WARNING: a local reference to the passed map object is held by this event after this method is called. The event map may not be deleted until the [Event::delChain](#) method has been used to remove this reference. This is not handled automatically by the [EventMap](#) destructor.

Parameters

<i>map</i>	The map to chain.
<i>mask</i>	The bit(s) to set/clear in the chained map based on the state of this event.

5.49.3.7 const Error * setValue (uint32 val)

Change the value that the event will wait for.

The event's value can not be changed while it is attached to an [EventMap](#) object. If this is attempted, then [&EventError::AlreadyOwned](#) will be returned.

Parameters

<i>val</i>	The new event value
------------	---------------------

Returns

A pointer to an error object, or NULL on success.

5.49.3.8 const Error * Wait (EventMap & m, Timeout timeout)

Wait on an event.

This function causes the calling thread to pend until the event is true, or the timeout expires.

Note that the event should not be owned by any event map when this is called.

Parameters

<i>m</i>	The event map that this event should watch.
<i>timeout</i>	The maximum amount of time to wait (milliseconds). If < 0, then the task will wait forever.

Returns

A pointer to an error object on failure, or NULL on success.

The documentation for this class was generated from the following files:

- [CML_EventMap.h](#)
- [EventMap.cpp](#)

5.50 EventAll Class Reference

This is an event that matches if all of a group of bits are set in the [EventMap](#) mask.

Inheritance diagram for EventAll:

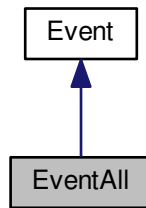

Collaboration diagram for EventAll:

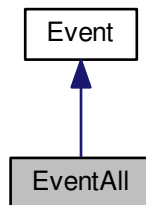
**Public Member Functions**

- [EventAll](#) (uint32 v=0)
Construct a new object specifying a group of bits that should be checked.
- [EventAll](#) (const [EventAll](#) &e)

Construct a new event object using the value of a passed event.

- virtual bool `isTrue` (uint32 mask)

Check the event against the passed mask.

Additional Inherited Members

5.50.1 Detailed Description

This is an event that matches if all of a group of bits are set in the [EventMap](#) mask.

5.50.2 Constructor & Destructor Documentation

5.50.2.1 `EventAll (uint32 v = 0) [inline]`

Construct a new object specifying a group of bits that should be checked.

Parameters

<code>v</code>	The bit mask that the event will wait on. Default is zero
----------------	---

5.50.2.2 `EventAll (const EventAll & e) [inline]`

Construct a new event object using the value of a passed event.

Parameters

<code>e</code>	Another event object who's value will be used to initialize this one.
----------------	---

5.50.3 Member Function Documentation

5.50.3.1 `virtual bool isTrue (uint32 mask) [inline],[virtual]`

Check the event against the passed mask.

If all of the selected bits are set in the mask, then the event is satisfied.

Parameters

<code>mask</code>	The mask to test against
-------------------	--------------------------

Returns

true if all bits of interest are set in the mask.

Reimplemented from [Event](#).

The documentation for this class was generated from the following file:

- [CML_EventMap.h](#)

5.51 EventAny Class Reference

This is an event that matches if any of a group of bits are set in the [EventMap](#) mask.

Inheritance diagram for EventAny:

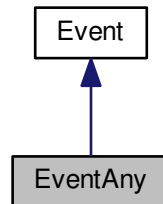

Collaboration diagram for EventAny:

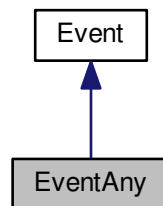

Public Member Functions

- [EventAny](#) (uint32 v=0)
Construct a new object specifying a group of bits that should be checked.
- [EventAny](#) (const [EventAny](#) &e)
Construct a new event object using the value of a passed event.
- virtual bool [isTrue](#) (uint32 mask)
Check the event.

Additional Inherited Members

5.51.1 Detailed Description

This is an event that matches if any of a group of bits are set in the [EventMap](#) mask.

5.51.2 Constructor & Destructor Documentation

5.51.2.1 EventAny (uint32 v = 0) [inline]

Construct a new object specifying a group of bits that should be checked.

Parameters

<i>v</i>	The bit mask that the event will wait on. Default is zero
----------	---

5.51.2.2 EventAny (const EventAny & e) [inline]

Construct a new event object using the value of a passed event.

Parameters

<i>e</i>	Another event object who's value will be used to initialize this one.
----------	---

5.51.3 Member Function Documentation

5.51.3.1 virtual bool isTrue (uint32 mask) [inline], [virtual]

Check the event.

The event is satisfied if any of the selected bits are set in the mask.

Parameters

<i>mask</i>	Bitmap identifying the event bits that are of interest.
-------------	---

Returns

true if any bits of interest are set in the mask.

Reimplemented from [Event](#).

The documentation for this class was generated from the following file:

- [CML_EventMap.h](#)

5.52 EventAnyClear Class Reference

This is an event that matches if any of a group of bits are clear in the [EventMap](#) mask.

Inheritance diagram for EventAnyClear:

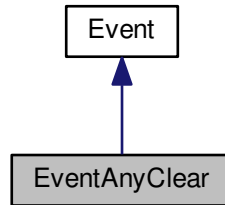

Collaboration diagram for EventAnyClear:

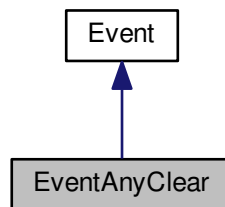

Public Member Functions

- [EventAnyClear](#) (uint32 v=0)
Construct a new object specifying a group of bits that should be checked.
- [EventAnyClear](#) (const [EventAnyClear](#) &e)
Construct a new event object using the value of a passed event.
- virtual bool [isTrue](#) (uint32 mask)
Check the event.

Additional Inherited Members

5.52.1 Detailed Description

This is an event that matches if any of a group of bits are clear in the [EventMap](#) mask.

5.52.2 Constructor & Destructor Documentation

5.52.2.1 EventAnyClear(uint32 v=0) [inline]

Construct a new object specifying a group of bits that should be checked.

Parameters

<i>v</i>	The bit mask that the event will wait on. Default is zero
----------	---

5.52.2.2 `EventAnyClear (const EventAnyClear & e) [inline]`

Construct a new event object using the value of a passed event.

Parameters

<i>e</i>	Another event object who's value will be used to initialize this one.
----------	---

5.52.3 Member Function Documentation

5.52.3.1 `virtual bool isTrue (uint32 mask) [inline],[virtual]`

Check the event.

The event is satisfied if any of the selected bits are clear in the mask.

Parameters

<i>mask</i>	A bitmap identifying the event bits of interest.
-------------	--

Returns

true if any bits of interest are set in the mask.

Reimplemented from [Event](#).

The documentation for this class was generated from the following file:

- [CML_EventMap.h](#)

5.53 EventError Class Reference

This class represents error conditions related to the [Event](#) object.

Inheritance diagram for EventError:

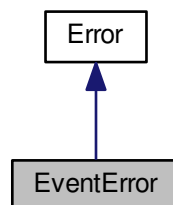

Collaboration diagram for EventError:

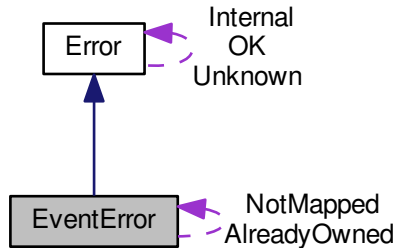

Static Public Attributes

- static const [EventError AlreadyOwned](#)
The event is already mapped to another object.
- static const [EventError NotMapped](#)
The event is not mapped to this object.

Protected Member Functions

- [EventError](#) (uint16 id, const char *desc)
Standard protected constructor.

Additional Inherited Members

5.53.1 Detailed Description

This class represents error conditions related to the [Event](#) object.

The documentation for this class was generated from the following file:

- [CML_EventMap.h](#)

5.54 EventMap Class Reference

An event map is a mechanism that allows one or more threads to wait on some pre-defined event, or group of events.

Public Member Functions

- virtual [~EventMap](#) (void)
Event map destructor.

- `const Error * Add (Event *e)`
Add the passed event to the list of events pending on this map.
- `const Error * Remove (Event *e)`
Remove the passed event from the list of events pending on this map.
- `uint32 getMask (void)`
Get the current value of the mask for this event map.
- `void setMask (uint32 mask)`
Update the event mask.
- `void setBits (uint32 bits)`
Set bits in the event mask.
- `void clrBits (uint32 bits)`
Clear bits in the event mask.
- `void changeBits (uint32 bits, uint32 value)`
Change the value of specified bits in the mask for this event.

Friends

- class **Event**

5.54.1 Detailed Description

An event map is a mechanism that allows one or more threads to wait on some pre-defined event, or group of events.

For a particular event map, there are one or more events that are grouped with that map. Any number of threads may pend on the state of these events.

5.54.2 Constructor & Destructor Documentation

5.54.2.1 `~EventManager (void) [virtual]`

[Event](#) map destructor.

Removes any attached events Note that it is an error to destroy an [EventManager](#) if it is currently pointed to by any events using 'setChain'. Make sure to remove any such chaining before the event map is destroyed.

5.54.3 Member Function Documentation

5.54.3.1 `const Error * Add (Event * e)`

Add the passed event to the list of events pending on this map.

If the event is already mapped to a map (this one or another) then this function will return [&EventManager::AlreadyOwned](#).

Parameters

<i>e</i>	Points to the event to add
----------	----------------------------

Returns

A pointer to an error object on failure, or NULL on success.

5.54.3.2 void changeBits (uint32 bits, uint32 value) [inline]

Change the value of specified bits in the mask for this event.

The bits to change are identified by one parameter, and the new value for these bits is specified in the other parameter.

Parameters

<i>bits</i>	Identifies which bits in the mask to change. Only those bits which are set in this parameter will be effected in the event mask.
<i>value</i>	The new value for the bits identified in the first parameter.

5.54.3.3 void clrBits (uint32 bits) [inline]

Clear bits in the event mask.

Parameters

<i>bits</i>	Any bit set in this parameter will be cleared in the event mask.
-------------	--

5.54.3.4 uint32 getMask (void) [inline]

Get the current value of the mask for this event map.

Returns

The 32-bit mask value.

5.54.3.5 const Error * Remove (Event * e)

Remove the passed event from the list of events pending on this map.

If the event is not presently attached to this map, then this function will return [&EventError::NotMapped](#).

Parameters

<i>e</i>	Points to the event to remove
----------	-------------------------------

Returns

A pointer to an error object on failure, or NULL on success.

5.54.3.6 void setBits (uint32 bits) [inline]

Set bits in the event mask.

Parameters

<i>bits</i>	Any bit set in this parameter will be set in the event mask.
-------------	--

5.54.3.7 `void setMask (uint32 mask) [inline]`

Update the event mask.

The new mask value will equal the passed parameter.

Parameters

<i>mask</i>	The new mask value.
-------------	---------------------

The documentation for this class was generated from the following files:

- [CML_EventMap.h](#)
- [EventMap.cpp](#)

5.55 EventNone Class Reference

This is an event that matches if none of a group of bits are set in the [EventMap](#) mask.

Inheritance diagram for EventNone:

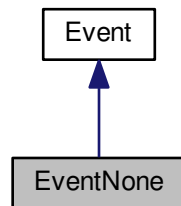

Collaboration diagram for EventNone:

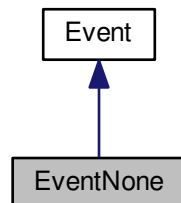

Public Member Functions

- [EventNone](#) (uint32 v=0)
Construct a new object specifying a group of bits that should be checked.
- [EventNone](#) (const [EventNone](#) &e)

Construct a new event object using the value of a passed event.

- virtual bool `isTrue` (uint32 mask)

Check the event against the passed mask.

Additional Inherited Members

5.55.1 Detailed Description

This is an event that matches if none of a group of bits are set in the [EventMap](#) mask.

5.55.2 Constructor & Destructor Documentation

5.55.2.1 `EventNone (uint32 v = 0) [inline]`

Construct a new object specifying a group of bits that should be checked.

Parameters

<code>v</code>	The bit mask that the event will wait on. Default is zero
----------------	---

5.55.2.2 `EventNone (const EventNone & e) [inline]`

Construct a new event object using the value of a passed event.

Parameters

<code>e</code>	Another event object who's value will be used to initialize this one.
----------------	---

5.55.3 Member Function Documentation

5.55.3.1 `virtual bool isTrue (uint32 mask) [inline],[virtual]`

Check the event against the passed mask.

If none of the selected bits are set in the mask, then the event is satisfied.

Parameters

<code>mask</code>	The mask to test against
-------------------	--------------------------

Returns

true if none bits of interest are set in the mask.

Reimplemented from [Event](#).

The documentation for this class was generated from the following file:

- [CML_EventMap.h](#)

5.56 Filter Class Reference

Generic filter structure.

Public Member Functions

- [Filter](#) (void)
Default constructor for filter object.
- const [Error](#) * [LoadFromCCX](#) (int32 coef[], int ct)
Load the filter coefficients from an array of integer values read from a .ccx file.
- void [getIntCoef](#) (int16 &a1, int16 &a2, int16 &b0, int16 &b1, int16 &b2, int16 &k)
Return the filter coefficients in integer format as used by DSP based amplifiers.
- void [getFloatCoef](#) (float &a1, float &a2, float &b0, float &b1, float &b2)
Return the filter coefficients in floating point format as used by FPGA based amplifiers.

5.56.1 Detailed Description

Generic filter structure.

This structure holds the coefficients used by the amplifier in various configurable filters.

5.56.2 Constructor & Destructor Documentation

5.56.2.1 [Filter](#) (void)

Default constructor for filter object.

Simply sets all coefficients to zero.

5.56.3 Member Function Documentation

5.56.3.1 [const Error * LoadFromCCX \(int32 coef\[\], int ct \)](#)

Load the filter coefficients from an array of integer values read from a .ccx file.

For DSP based amps the ccx file contains an array of 9 short integers holding the coefficient data. For FPGA based amps the ccx file holds an array of 7 long integer values.

Parameters

<i>coef</i>	The array of coefficient data read from the ccx file
<i>ct</i>	The number of coefficients (should be either 7 or 9)

Returns

An error pointer or NULL on success

The documentation for this class was generated from the following files:

- [CML_Filter.h](#)
- [Filter.cpp](#)

5.57 Firmware Class Reference

Copley Controls amplifier firmware object.

Public Member Functions

- [uint16 getFileVersion](#) ()
Returns the firmware file version number.
- [uint16 getAmpType](#) ()
Returns the amplifier type for this firmware.
- [uint32 getStart](#) ()
Returns the firmware starting address.
- [uint32 getLength](#) ()
Returns the firmware length (in words)
- [uint16 * getData](#) (void)
Returns the firmware binary data.
- virtual void [progress](#) (uint32 addr)
This virtual function is called repeatedly during an amplifier firmware update.

5.57.1 Detailed Description

Copley Controls amplifier firmware object.

This object is used to represent a firmware file which can be uploaded to an amplifier.

Note that uploading firmware to the amplifier is not part of normal operation. The amplifier firmware is stored in internal Flash memory, and only needs to be updated if a new version with new features or bug fixes is produced by Copley Controls Corporation.

5.57.2 Member Function Documentation

5.57.2.1 [uint16 getAmpType](#) () [inline]

Returns the amplifier type for this firmware.

Returns

The amplifier type for this firmware

5.57.2.2 [uint16* getData](#) (void) [inline]

Returns the firmware binary data.

Returns

The firmware binary data

5.57.2.3 uint16 getFileVersion () [inline]

Returns the firmware file version number.

Returns

The firmware file version number

5.57.2.4 uint32 getLength () [inline]

Returns the firmware length (in words)

Returns

The firmware length (in words)

5.57.2.5 uint32 getStart () [inline]

Returns the firmware starting address.

Returns

The firmware starting address

5.57.2.6 virtual void progress (uint32 addr) [inline],[virtual]

This virtual function is called repeatedly during an amplifier firmware update.

It can be overloaded to display the progress of the download. This version does nothing.

Parameters

<i>addr</i>	The address currently being downloaded.
-------------	---

The documentation for this class was generated from the following file:

- [CML_Firmware.h](#)

5.58 FirmwareError Class Reference

This class represents error conditions that can occur while accessing a Copley Controls amplifier firmware object.

Inheritance diagram for FirmwareError:

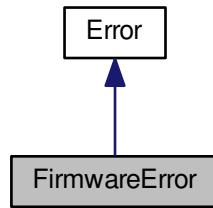

Collaboration diagram for FirmwareError:

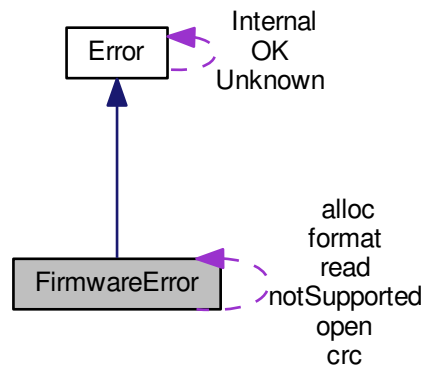

Static Public Attributes

- static const [FirmwareError open](#)
Unable to open specified firmware file.
- static const [FirmwareError read](#)
Error reading from firmware file.
- static const [FirmwareError format](#)
File format error.
- static const [FirmwareError crc](#)
File CRC error.
- static const [FirmwareError alloc](#)
Memory allocation error.

- static const [FirmwareError notSupported](#)

Firmware update not supported.

Protected Member Functions

- [FirmwareError](#) (uint16 id, const char *desc)

Standard protected constructor.

Additional Inherited Members

5.58.1 Detailed Description

This class represents error conditions that can occur while accessing a Copley Controls amplifier firmware object.

The documentation for this class was generated from the following file:

- [CML_Firmware.h](#)

5.59 FPRD Struct Reference

Read by assigned node ID (Configured Address Physical Read) The master assigns each node a unique 16-bit address at startup.

Inheritance diagram for FPRD:

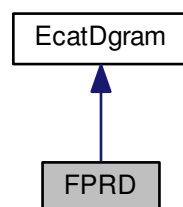

Collaboration diagram for FPRD:

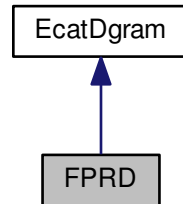

Additional Inherited Members

5.59.1 Detailed Description

Read by assigned node ID (Configured Address Physical Read) The master assigns each node a unique 16-bit address at startup.

This datagram reads from memory locations within the slave based on these assigned addresses

The documentation for this struct was generated from the following file:

- [CML_EtherCAT.h](#)

5.60 FPWR Struct Reference

Write by assigned node ID (Configured Address Physical Write)

Inheritance diagram for FPWR:

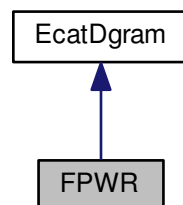

Collaboration diagram for FPWR:

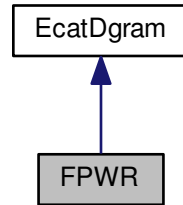

Additional Inherited Members

5.60.1 Detailed Description

Write by assigned node ID (Configured Address Physical Write)

The documentation for this struct was generated from the following file:

- [CML_EtherCAT.h](#)

5.61 FuncGenConfig Struct Reference

Configuration parameters for amplifier's internal function generator.

Public Member Functions

- [FuncGenConfig](#) (void)
Default constructor, sets all members to zero.

Public Attributes

- [int16 cfg](#)
Configuration.
- [int16 duty](#)
Duty cycle in 0.1% (i.e. 0 to 1000)
- [int16 freq](#)
Frequency (Hz)
- [int32 amp](#)
Amplitude.

5.61.1 Detailed Description

Configuration parameters for amplifier's internal function generator.

5.61.2 Member Data Documentation

5.61.2.1 int32 amp

Amplitude.

Units depend on what the function generator is driving 0.01 Amps for current. 0.1 encoder counts/sec for velocity. Encoder counts for position.

The documentation for this struct was generated from the following file:

- [CML_AmpStruct.h](#)

5.62 GainScheduling Struct Reference

Configuration structure used to set up the Gain Scheduling.

Public Member Functions

- [GainScheduling](#) (void)
Default constructor.

Public Attributes

- [uint32 gainSchedulingConfig](#)
Gain Scheduling configuration. See documentation for details.

5.62.1 Detailed Description

Configuration structure used to set up the Gain Scheduling.

These settings may be up/download from the amplifier using the functions [Amp::SetGainScheduling](#) and [Amp::GetGainScheduling](#).

5.62.2 Constructor & Destructor Documentation

5.62.2.1 GainScheduling (void) [inline]

Default constructor.

Initializes all structure elements to zero.

The documentation for this struct was generated from the following file:

- [CML_AmpStruct.h](#)

5.63 HomeConfig Struct Reference

Homing parameter structure.

Public Member Functions

- [HomeConfig](#) (void)

Default constructor, just set the method to none and the other parameters to zero.

Public Attributes

- [COPLEY_HOME_METHOD](#) method

Homing method to use.

- [uint16 extended](#)

Extended home method.

- [uunit velFast](#)

Velocity to use for fast moves during the home procedure.

- [uunit velSlow](#)

Velocity to use when seeking a sensor edge.

- [uunit accel](#)

Acceleration to use for the home procedure.

- [uunit offset](#)

Offset from located home position to zero position.

- [int16 current](#)

Home current limit.

- [int16 delay](#)

Home delay.

5.63.1 Detailed Description

Homing parameter structure.

This structure allows all homing parameters to be grouped together and passed to the amplifier for convenience.

5.63.2 Constructor & Destructor Documentation

5.63.2.1 [HomeConfig](#) (void) `[inline]`

Default constructor, just set the method to none and the other parameters to zero.

5.63.3 Member Data Documentation

5.63.3.1 [uunit accel](#)

Acceleration to use for the home procedure.

This parameter is specified in "user units". See [Amp::SetCountsPerUnit](#) for details.

5.63.3.2 int16 current

Home current limit.

This parameter is only used when running in one of the 'home to hard stop' homing modes. In all other modes this parameter may be left uninitialized. The current should be specified in units of 0.01 Amps (i.e. 100 for 1.0 [Amp](#))

5.63.3.3 int16 delay

Home delay.

This parameter is only used when running in one of the 'home to hard stop' homing modes. In all other modes this parameter may be left uninitialized. The delay is specified in units of milliseconds.

5.63.3.4 uint16 extended

Extended home method.

If the main home method is set to any value other than 'CHM_EXTENDED' then this parameter is ignored. If the home method is set to this value, then this value will be used to define the low level homing routine used by the amplifier.

For the most part this parameter can be ignored. It's intended to allow access to some low level features of the amplifier's homing state machine which are otherwise not available through the more generic home methods.

Encodings for this parameter can be found in the CANopen programmers guide for CANopen object 0x2352, or in the serial port programmers guide for variable 0xC2.

5.63.3.5 uint offset

Offset from located home position to zero position.

After the home position is found as defined by the home method, this offset will be added to it and the resulting position will be considered the zero position. This parameter is specified in "user units". See [Amp::SetCountsPerUnit](#) for details.

5.63.3.6 uint velFast

Velocity to use for fast moves during the home procedure.

This parameter is specified in "user units". See [Amp::SetCountsPerUnit](#) for details.

5.63.3.7 uint velSlow

Velocity to use when seeking a sensor edge.

This parameter is specified in "user units". See [Amp::SetCountsPerUnit](#) for details.

The documentation for this struct was generated from the following file:

- [CML_AmpStruct.h](#)

5.64 InputShaper Class Reference

Generic input shaper structure.

Public Member Functions

- [InputShaper](#) (void)
Default constructor for [InputShaper](#) object.
- const [Error](#) * [LoadFromCCX](#) (int32 inputShaping[], int ct)
Load the filter coefficients from an array of integer values read from a .ccx file.
- void [setInputShapeFilter](#) (float inputShaperData[])
Return the amplitude for each impulse in the input shaping filter.

5.64.1 Detailed Description

Generic input shaper structure.

This structure holds the amplitudes and times of the impulse functions used to create the input shaper, as well as the info used by CME2 to indentify the filter type and settings.

5.64.2 Constructor & Destructor Documentation

5.64.2.1 InputShaper (void)

Default constructor for [InputShaper](#) object.

Simply sets all impulses to 0

5.64.3 Member Function Documentation

5.64.3.1 const [Error](#) * [LoadFromCCX](#) (int32 *inputShaping*[], int *ct*)

Load the filter coefficients from an array of integer values read from a .ccx file.

The .ccx file holds an array of 20 long integer values for the input shaping filter.

Parameters

<i>inputShaping</i>	The array of input shaping data read from the ccx file
<i>ct</i>	The number of coefficients (should be 20)

Returns

An error pointer or NULL on success

The documentation for this class was generated from the following files:

- [CML_InputShaper.h](#)
- [InputShaper.cpp](#)

5.65 IOError Class Reference

I/O module errors.

Inheritance diagram for IOError:

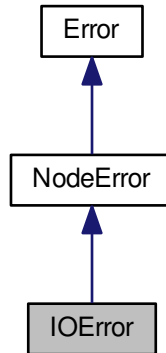

Collaboration diagram for IOError:

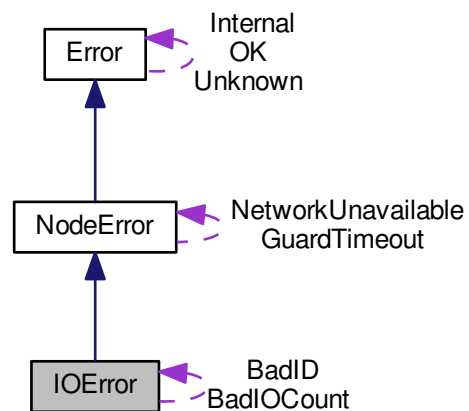

Static Public Attributes

- static const `IOError BadID`
The passed digital I/O pin ID number is invalid.
- static const `IOError BadIOCount`
The number of passed I/O ID blocks is invalid.

Protected Member Functions

- [IOError](#) (uint16 id, const char *desc)

Standard protected constructor.

Additional Inherited Members

5.65.1 Detailed Description

I/O module errors.

This class is used to represent errors that may be returned by a standard I/O module.

The documentation for this class was generated from the following file:

- [CML_IO.h](#)

5.66 IOError Class Reference

This class represents error conditions that can occur when loading IO module data from a data file.

Inheritance diagram for IOError:

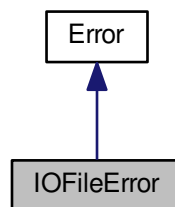

Collaboration diagram for IOFileError:

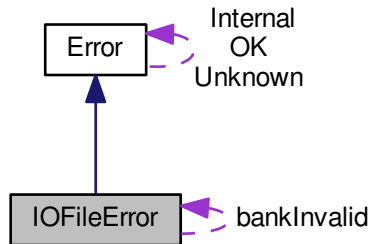

Static Public Attributes

- static const [IOFileError](#) `bankInvalid`

I/O bank invalid.

Protected Member Functions

- [IOFileError](#) (`uint16 id, const char *desc`)

Standard protected constructor.

Additional Inherited Members

5.66.1 Detailed Description

This class represents error conditions that can occur when loading IO module data from a data file.

The documentation for this class was generated from the following file:

- [CML_CopleyIO.h](#)

5.67 IOModule Class Reference

Standard CANopen I/O module.

Inheritance diagram for IOModule:

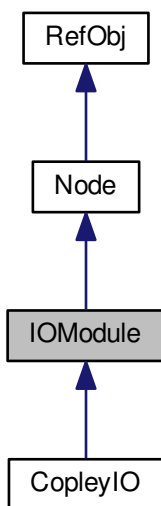

Collaboration diagram for IOModule:

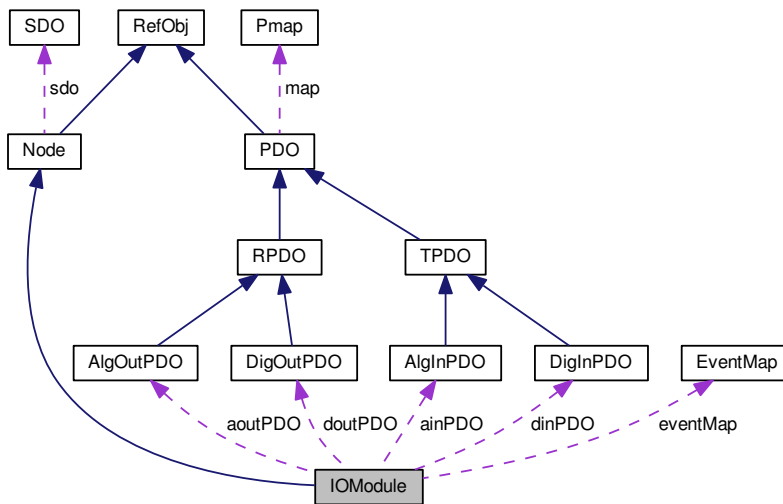

Classes

- class [AlgInPDO](#)

- Transmit PDO for mapping analog inputs.*
- class [AlgOutPDO](#)
 - Receive PDO for mapping analog outputs.*
- class [DigInPDO](#)
 - Transmit PDO for mapping digital inputs.*
- class [DigOutPDO](#)
 - Receive PDO for mapping digital output pins.*

Public Member Functions

- [IOModule](#) (void)
 - Default constructor for an I/O module.*
- [IOModule](#) ([Network](#) &net, [int16](#) nodeID)
 - Construct an [IOModule](#) object and initialize it using default settings.*
- [IOModule](#) ([Network](#) &net, [int16](#) nodeID, [IOModuleSettings](#) &settings)
 - Construct an [IOModule](#) object and initialize it using custom settings.*
- virtual [~IOModule](#) ()
 - Virtual destructor for the [IOModule](#) object.*
- virtual const [Error](#) * [Init](#) ([Network](#) &net, [int16](#) nodeID)
 - Initialize an I/O module using default settings.*
- virtual const [Error](#) * [Init](#) ([Network](#) &net, [int16](#) nodeID, [IOModuleSettings](#) &settings)
 - Initialize an I/O module using custom settings.*
- virtual const [Error](#) * [WaitIOEvent](#) ([IOMODULE_EVENTS](#) event, Timeout timeout=-1)
 - Wait on an event associated with this I/O module.*
- virtual const [Error](#) * [WaitIOEvent](#) ([Event](#) &e, Timeout timeout, [IOMODULE_EVENTS](#) &match)
 - Wait for an event associated with this I/O module.*

Digital input control

If the module contains digital inputs, these methods may be used to configure and read those inputs.

The inputs may be read and controlled individually, or in groups of 8, 16 or 32 inputs.

All I/O modules should support access to digital inputs in groups of 8. Support for individual access or different groupings is optional under the spec. If a particular device does not support such groupings, an attempt to use them should return an error code.

Each input pin or group of pins is assigned an ID number used to access it. When single inputs are accessed, these ID numbers range from 0 (the first input) to N-1 (the last input), where N is the total number of input pins available on the module.

When groups of inputs are accessed as a unit, the group is assigned a number. The first group of inputs will be assigned ID number 0, the second will be ID 1, etc. The number of groups of a particular size will be the total number of inputs divided by the group size.

For example, to access the fifty third input pin individually you would use id number 52. To access it as part of a group of 8 inputs, you would access group number 6 (52/8). Input 52 would be bit 4 (52%8) of that group.

- virtual const [Error](#) * [DinGetIntEna](#) (bool &value)
 - Get the current setting of the global interrupt enable for digital inputs.*
- virtual const [Error](#) * [DinSetIntEna](#) (bool value)
 - Set the current setting of the global interrupt enable for digital inputs.*
- virtual const [Error](#) * [DinGetCt](#) ([uint16](#) &ct)
 - Return the number of individual inputs available on this device.*

- virtual const [Error](#) * [DinRead](#) (uint16 id, bool &value, bool viaSDO=false)
Read a single digital input.
- virtual const [Error](#) * [DinGetPol](#) (uint16 id, bool &value)
Get the current polarity settings for a digital input.
- virtual const [Error](#) * [DinSetPol](#) (uint16 id, bool value)
Set the current polarity setting for a digital input.
- virtual const [Error](#) * [DinGetFilt](#) (uint16 id, bool &value)
Get the current filter constant setting for a digital input.
- virtual const [Error](#) * [DinSetFilt](#) (uint16 id, bool value)
Set the current filter constant setting for a digital input.
- virtual const [Error](#) * [DinGetMaskAny](#) (uint16 id, bool &value)
Get the 'any transition' interrupt mask settings for a digital input.
- virtual const [Error](#) * [DinSetMaskAny](#) (uint16 id, bool value)
Set the 'any transition' interrupt mask settings for a digital input.
- virtual const [Error](#) * [DinGetMaskLow2High](#) (uint16 id, bool &value)
Get the 'low to high' interrupt mask settings for a digital input.
- virtual const [Error](#) * [DinSetMaskLow2High](#) (uint16 id, bool value)
Set the 'low to high' interrupt mask settings for a digital input.
- virtual const [Error](#) * [DinGetMaskHigh2Low](#) (uint16 id, bool &value)
Get the 'high to low' interrupt mask settings for a digital input.
- virtual const [Error](#) * [DinSetMaskHigh2Low](#) (uint16 id, bool value)
Set the 'high to low' interrupt mask settings for a digital input.
- virtual const [Error](#) * [Din8GetCt](#) (uint8 &ct)
Return the number of 8-bit groups of inputs available on this device.
- virtual const [Error](#) * [Din8Read](#) (uint8 id, uint8 &value, bool viaSDO=false)
Read a group of 8 digital inputs.
- virtual const [Error](#) * [Din8GetPol](#) (uint8 id, uint8 &value)
Get the current polarity settings for a group of 8 digital inputs.
- virtual const [Error](#) * [Din8SetPol](#) (uint8 id, uint8 value)
Set the current polarity setting for a group of 8 digital inputs.
- virtual const [Error](#) * [Din8GetFilt](#) (uint8 id, uint8 &value)
Get the current filter constant settings for a group of 8 digital inputs.
- virtual const [Error](#) * [Din8SetFilt](#) (uint8 id, uint8 value)
Set the current filter constant setting for a group of 8 digital inputs.
- virtual const [Error](#) * [Din8GetMaskAny](#) (uint8 id, uint8 &value)
Get the 'any transition' interrupt mask settings for a group of 8 digital inputs.
- virtual const [Error](#) * [Din8SetMaskAny](#) (uint8 id, uint8 value)
Set the 'any transition' interrupt mask settings for a group of 8 digital inputs.
- virtual const [Error](#) * [Din8GetMaskLow2High](#) (uint8 id, uint8 &value)
Get the 'low to high' interrupt mask settings for a group of 8 digital inputs.
- virtual const [Error](#) * [Din8SetMaskLow2High](#) (uint8 id, uint8 value)
Set the 'low to high' interrupt mask settings for a group of 8 digital inputs.
- virtual const [Error](#) * [Din8GetMaskHigh2Low](#) (uint8 id, uint8 &value)
Get the 'high to low' interrupt mask settings for a group of 8 digital inputs.
- virtual const [Error](#) * [Din8SetMaskHigh2Low](#) (uint8 id, uint8 value)
Set the 'high to low' interrupt mask settings for a group of 8 digital inputs.
- virtual const [Error](#) * [Din16GetCt](#) (uint8 &ct)
Return the number of 16-bit groups of inputs available on this device.
- virtual const [Error](#) * [Din16Read](#) (uint8 id, uint16 &value, bool viaSDO=false)
Read a group of 16 digital inputs.
- virtual const [Error](#) * [Din16GetPol](#) (uint8 id, uint16 &value)
Get the current polarity settings for a group of 16 digital inputs.
- virtual const [Error](#) * [Din16SetPol](#) (uint8 id, uint16 value)
Set the current polarity setting for a group of 16 digital inputs.
- virtual const [Error](#) * [Din16GetFilt](#) (uint8 id, uint16 &value)

- Get the current filter constant settings for a group of 16 digital inputs.*

 - virtual const [Error](#) * [Din16SetFilt](#) (uint8 id, uint16 value)

Set the current filter constant setting for a group of 16 digital inputs.

 - virtual const [Error](#) * [Din16GetMaskAny](#) (uint8 id, uint16 &value)

Get the 'any transition' interrupt mask settings for a group of 16 digital inputs.

 - virtual const [Error](#) * [Din16SetMaskAny](#) (uint8 id, uint16 value)

Set the 'any transition' interrupt mask settings for a group of 16 digital inputs.

 - virtual const [Error](#) * [Din16GetMaskLow2High](#) (uint8 id, uint16 &value)

Get the 'low to high' interrupt mask settings for a group of 16 digital inputs.

 - virtual const [Error](#) * [Din16SetMaskLow2High](#) (uint8 id, uint16 value)

Set the 'low to high' interrupt mask settings for a group of 16 digital inputs.

 - virtual const [Error](#) * [Din16GetMaskHigh2Low](#) (uint8 id, uint16 &value)

Get the 'high to low' interrupt mask settings for a group of 16 digital inputs.

 - virtual const [Error](#) * [Din16SetMaskHigh2Low](#) (uint8 id, uint16 value)

Set the 'high to low' interrupt mask settings for a group of 16 digital inputs.

 - virtual const [Error](#) * [Din32GetCt](#) (uint8 &ct)

Return the number of 32-bit groups of inputs available on this device.

 - virtual const [Error](#) * [Din32Read](#) (uint8 id, uint32 &value, bool viaSDO=false)

Read a group of 32 digital inputs.

 - virtual const [Error](#) * [Din32GetPol](#) (uint8 id, uint32 &value)

Get the current polarity settings for a group of 32 digital inputs.

 - virtual const [Error](#) * [Din32SetPol](#) (uint8 id, uint32 value)

Set the current polarity setting for a group of 32 digital inputs.

 - virtual const [Error](#) * [Din32GetFilt](#) (uint8 id, uint32 &value)

Get the current filter constant settings for a group of 32 digital inputs.

 - virtual const [Error](#) * [Din32SetFilt](#) (uint8 id, uint32 value)

Set the current filter constant setting for a group of 32 digital inputs.

 - virtual const [Error](#) * [Din32GetMaskAny](#) (uint8 id, uint32 &value)

Get the 'any transition' interrupt mask settings for a group of 32 digital inputs.

 - virtual const [Error](#) * [Din32SetMaskAny](#) (uint8 id, uint32 value)

Set the 'any transition' interrupt mask settings for a group of 32 digital inputs.

 - virtual const [Error](#) * [Din32GetMaskLow2High](#) (uint8 id, uint32 &value)

Get the 'low to high' interrupt mask settings for a group of 32 digital inputs.

 - virtual const [Error](#) * [Din32SetMaskLow2High](#) (uint8 id, uint32 value)

Set the 'low to high' interrupt mask settings for a group of 32 digital inputs.

 - virtual const [Error](#) * [Din32GetMaskHigh2Low](#) (uint8 id, uint32 &value)

Get the 'high to low' interrupt mask settings for a group of 32 digital inputs.

 - virtual const [Error](#) * [Din32SetMaskHigh2Low](#) (uint8 id, uint32 value)

Set the 'high to low' interrupt mask settings for a group of 32 digital inputs.

Digital output control

If the module contains digital outputs, these methods may be used to configure and set those outputs.

The outputs may be set and controlled individually, or in groups of 8, 16 or 32 outputs.

All I/O modules should support access to digital outputs in groups of 8. Support for individual access or different groupings is optional under the spec. If a particular device does not support such groupings, an attempt to use them should return an error code.

Each output pin or group of pins is assigned an ID number used to access it. When single outputs are accessed, these ID numbers range from 0 (the first output) to N-1 (the last output), where N is the total number of output pins available on the module.

When groups of outputs are accessed as a unit, the group is assigned a number. The first group of outputs will be assigned ID number 0, the second will be ID 1, etc. The number of groups of a particular size will be the total number of outputs divided by the group size.

For example, to access the twenty seventh output pin individually you would use id number 26. To access it as part of a group of 8 outputs, you would access group number 3 (26/8). Output 26 would be bit 2 (26%8) of that group.

- virtual const [Error](#) * [DoutGetCt](#) (uint16 &ct)
Return the number of individual outputs available on this device.
- virtual const [Error](#) * [DoutWrite](#) (uint16 id, bool value, bool viaSDO=false)
Write an individual digital output.
- virtual const [Error](#) * [DoutGetPol](#) (uint16 id, bool &value)
Get the current polarity setting for an individual digital output.
- virtual const [Error](#) * [DoutSetPol](#) (uint16 id, bool value)
Set the current polarity setting for an individual digital output.
- virtual const [Error](#) * [DoutGetFilt](#) (uint16 id, bool &value)
Get the current filter constant setting for an individual digital output.
- virtual const [Error](#) * [DoutSetFilt](#) (uint16 id, bool value)
Set the current filter constant setting for an individual digital output.
- virtual const [Error](#) * [DoutGetErrMode](#) (uint16 id, bool &value)
Get the current error mode setting for an individual digital output.
- virtual const [Error](#) * [DoutSetErrMode](#) (uint16 id, bool value)
Set the current error mode setting for an individual digital output.
- virtual const [Error](#) * [DoutGetErrValue](#) (uint16 id, bool &value)
Get the current error value setting for an individual digital output.
- virtual const [Error](#) * [DoutSetErrValue](#) (uint16 id, bool value)
Set the current error value setting for an individual digital output.
- virtual const [Error](#) * [Dout8GetCt](#) (uint8 &ct)
Return the number of 8-bit groups of outputs available on this device.
- const [Error](#) * [Dout8Write](#) (uint8 id, uint8 value, bool viaSDO=false)
Write a group of 8 digital outputs.
- const [Error](#) * [Dout8Read](#) (uint8 id, uint8 &value)
Read back the last value written to this bank of 8 digital outputs.
- virtual const [Error](#) * [Dout8GetPol](#) (uint8 id, uint8 &value)
Get the current polarity settings for a group of 8 digital outputs.
- virtual const [Error](#) * [Dout8SetPol](#) (uint8 id, uint8 value)
Set the current polarity setting for a group of 8 digital outputs.
- virtual const [Error](#) * [Dout8GetFilt](#) (uint8 id, uint8 &value)
Get the current filter constant settings for a group of 8 digital outputs.
- virtual const [Error](#) * [Dout8SetFilt](#) (uint8 id, uint8 value)
Set the current filter constant setting for a group of 8 digital outputs.
- virtual const [Error](#) * [Dout8GetErrMode](#) (uint8 id, uint8 &value)
Get the current error mode settings for a group of 8 digital outputs.
- virtual const [Error](#) * [Dout8SetErrMode](#) (uint8 id, uint8 value)
Set the current error mode settings for a group of 8 digital outputs.
- virtual const [Error](#) * [Dout8GetErrValue](#) (uint8 id, uint8 &value)
Get the current error value settings for a group of 8 digital outputs.
- virtual const [Error](#) * [Dout8SetErrValue](#) (uint8 id, uint8 value)
Set the current error value settings for a group of 8 digital outputs.
- virtual const [Error](#) * [Dout16GetCt](#) (uint8 &ct)
Return the number of 16-bit groups of outputs available on this device.
- virtual const [Error](#) * [Dout16Write](#) (uint8 id, uint16 value, bool viaSDO=false)
Write a group of 16 digital outputs.
- const [Error](#) * [Dout16Read](#) (uint8 id, uint16 &value)
Read back the last value written to this bank of 16 digital outputs.
- virtual const [Error](#) * [Dout16GetPol](#) (uint8 id, uint16 &value)
Get the current polarity settings for a group of 16 digital outputs.
- virtual const [Error](#) * [Dout16SetPol](#) (uint8 id, uint16 value)
Set the current polarity setting for a group of 16 digital outputs.
- virtual const [Error](#) * [Dout16GetFilt](#) (uint8 id, uint16 &value)
Get the current filter constant settings for a group of 16 digital outputs.
- virtual const [Error](#) * [Dout16SetFilt](#) (uint8 id, uint16 value)

- Set the current filter constant setting for a group of 16 digital outputs.*
- virtual const [Error](#) * [Dout16GetErrMode](#) (uint8 id, uint16 &value)
- Get the current error mode settings for a group of 16 digital outputs.*
- virtual const [Error](#) * [Dout16SetErrMode](#) (uint8 id, uint16 value)
- Set the current error mode settings for a group of 16 digital outputs.*
- virtual const [Error](#) * [Dout16GetErrValue](#) (uint8 id, uint16 &value)
- Get the current error value settings for a group of 16 digital outputs.*
- virtual const [Error](#) * [Dout16SetErrValue](#) (uint8 id, uint16 value)
- Set the current error value settings for a group of 16 digital outputs.*
- virtual const [Error](#) * [Dout32GetCt](#) (uint8 &ct)
- Return the number of 32-bit groups of outputs available on this device.*
- virtual const [Error](#) * [Dout32Write](#) (uint8 id, uint32 value, bool viaSDO=false)
- Write a group of 32 digital outputs.*
- const [Error](#) * [Dout32Read](#) (uint8 id, uint32 &value)
- Read back the last value written to this bank of 32 digital outputs.*
- virtual const [Error](#) * [Dout32GetPol](#) (uint8 id, uint32 &value)
- Get the current polarity settings for a group of 32 digital outputs.*
- virtual const [Error](#) * [Dout32SetPol](#) (uint8 id, uint32 value)
- Set the current polarity setting for a group of 32 digital outputs.*
- virtual const [Error](#) * [Dout32GetFilt](#) (uint8 id, uint32 &value)
- Get the current filter constant settings for a group of 32 digital outputs.*
- virtual const [Error](#) * [Dout32SetFilt](#) (uint8 id, uint32 value)
- Set the current filter constant setting for a group of 32 digital outputs.*
- virtual const [Error](#) * [Dout32GetErrMode](#) (uint8 id, uint32 &value)
- Get the current error mode settings for a group of 32 digital outputs.*
- virtual const [Error](#) * [Dout32SetErrMode](#) (uint8 id, uint32 value)
- Set the current error mode settings for a group of 32 digital outputs.*
- virtual const [Error](#) * [Dout32GetErrValue](#) (uint8 id, uint32 &value)
- Get the current error value settings for a group of 32 digital outputs.*
- virtual const [Error](#) * [Dout32SetErrValue](#) (uint8 id, uint32 value)
- Set the current error value settings for a group of 32 digital outputs.*

Analog input control

If the module contains analog inputs, these methods may be used to configure and read those inputs.

Most manufacturers support 16-bit access to analog inputs. Other input sizes are optional in the spec. and may or may not be available.

- virtual const [Error](#) * [Ain8GetCt](#) (uint8 &ct)
- Return the number of 8-bit analog inputs available on this device.*
- virtual const [Error](#) * [Ain8Read](#) (uint8 id, int8 &value)
- Read an 8-bit analog input.*
- virtual const [Error](#) * [Ain16GetCt](#) (uint8 &ct)
- Return the number of 16-bit analog inputs available on this device.*
- virtual const [Error](#) * [Ain16Read](#) (uint8 id, int16 &value, bool viaSDO=false)
- Read a 16-bit analog input.*
- virtual const [Error](#) * [Ain32GetCt](#) (uint8 &ct)
- Return the number of 32-bit analog inputs available on this device.*
- virtual const [Error](#) * [Ain32Read](#) (uint8 id, int32 &value)
- Read a 32-bit analog input.*
- virtual const [Error](#) * [AinFltGetCt](#) (uint8 &ct)
- Return the number of floating point analog inputs available on this device.*
- virtual const [Error](#) * [AinFltRead](#) (uint8 id, float &value)
- Read a floating point analog input.*
- virtual const [Error](#) * [Ain32GetOffset](#) (uint8 id, int32 &value)

- Get the analog input offset value as a 32-bit integer.*

 - virtual const [Error](#) * [Ain32SetOffset](#) (uint8 id, int32 value)
- Set the analog input offset value as a 32-bit integer.*

 - virtual const [Error](#) * [Ain32GetScaling](#) (uint8 id, int32 &value)
- Get the analog input scaling factor as a 32-bit integer.*

 - virtual const [Error](#) * [Ain32SetScaling](#) (uint8 id, int32 value)
- Set the analog input scaling factor as a 32-bit integer.*

 - virtual const [Error](#) * [AinFltGetOffset](#) (uint8 id, float &value)
- Get the analog input offset value as a floating point value.*

 - virtual const [Error](#) * [AinFltSetOffset](#) (uint8 id, float value)
- Set the analog input offset value as a floating point value.*

 - virtual const [Error](#) * [AinFltGetScaling](#) (uint8 id, float &value)
- Get the analog input scaling factor as a floating point value.*

 - virtual const [Error](#) * [AinFltSetScaling](#) (uint8 id, float value)
- Set the analog input scaling factor as a floating point value.*

 - virtual const [Error](#) * [AinGetIntEna](#) (bool &value)
- Get the current setting of the global interrupt enable for analog inputs.*

 - virtual const [Error](#) * [AinSetIntEna](#) (bool value)
- Set the current setting of the global interrupt enable for analog inputs.*

 - virtual const [Error](#) * [AinGetTrigType](#) (uint8 id, IO_AIN_TRIG_TYPE &value)
- Get the analog input trigger type associated with the input channel.*

 - virtual const [Error](#) * [AinSetTrigType](#) (uint8 id, IO_AIN_TRIG_TYPE value)
- Set the analog input trigger type associated with the input channel.*

 - virtual const [Error](#) * [AinGetIntSource](#) (uint8 id, uint32 &value)
- Get the analog input interrupt source.*

 - virtual const [Error](#) * [Ain16GetUpperLimit](#) (uint8 id, int16 &value)
- Get the analog input upper limit value as a 16-bit integer.*

 - virtual const [Error](#) * [Ain16SetUpperLimit](#) (uint8 id, int16 value)
- Set the analog input upper limit value as a 16-bit integer.*

 - virtual const [Error](#) * [Ain16GetLowerLimit](#) (uint8 id, int16 &value)
- Get the analog input lower limit value as a 16-bit integer.*

 - virtual const [Error](#) * [Ain16SetLowerLimit](#) (uint8 id, int16 value)
- Set the analog input lower limit value as a 16-bit integer.*

 - virtual const [Error](#) * [Ain16GetUnsignedDelta](#) (uint8 id, int16 &value)
- Get the analog input unsigned delta value as a 16-bit integer.*

 - virtual const [Error](#) * [Ain16SetUnsignedDelta](#) (uint8 id, int16 value)
- Set the analog input unsigned delta value as a 16-bit integer.*

 - virtual const [Error](#) * [Ain16GetNegativeDelta](#) (uint8 id, int16 &value)
- Get the analog input negative delta value as a 16-bit integer.*

 - virtual const [Error](#) * [Ain16SetNegativeDelta](#) (uint8 id, int16 value)
- Set the analog input negative delta value as a 16-bit integer.*

 - virtual const [Error](#) * [Ain16GetPositiveDelta](#) (uint8 id, int16 &value)
- Get the analog input positive delta value as a 16-bit integer.*

 - virtual const [Error](#) * [Ain16SetPositiveDelta](#) (uint8 id, int16 value)
- Set the analog input positive delta value as a 16-bit integer.*

 - virtual const [Error](#) * [Ain32GetUpperLimit](#) (uint8 id, int32 &value)
- Get the analog input upper limit value as a 32-bit integer.*

 - virtual const [Error](#) * [Ain32SetUpperLimit](#) (uint8 id, int32 value)
- Set the analog input upper limit value as a 32-bit integer.*

 - virtual const [Error](#) * [Ain32GetLowerLimit](#) (uint8 id, int32 &value)
- Get the analog input lower limit value as a 32-bit integer.*

 - virtual const [Error](#) * [Ain32SetLowerLimit](#) (uint8 id, int32 value)
- Set the analog input lower limit value as a 32-bit integer.*

 - virtual const [Error](#) * [Ain32GetUnsignedDelta](#) (uint8 id, int32 &value)
- Get the analog input unsigned delta value as a 32-bit integer.*

- virtual const **Error** * **Ain32SetUnsignedDelta** (uint8 id, int32 value)
Set the analog input unsigned delta value as a 32-bit integer.
- virtual const **Error** * **Ain32GetNegativeDelta** (uint8 id, int32 &value)
Get the analog input negative delta value as a 32-bit integer.
- virtual const **Error** * **Ain32SetNegativeDelta** (uint8 id, int32 value)
Set the analog input negative delta value as a 32-bit integer.
- virtual const **Error** * **Ain32GetPositiveDelta** (uint8 id, int32 &value)
Get the analog input positive delta value as a 32-bit integer.
- virtual const **Error** * **Ain32SetPositiveDelta** (uint8 id, int32 value)
Set the analog input positive delta value as a 32-bit integer.
- virtual const **Error** * **AinFltGetUpperLimit** (uint8 id, float &value)
Get the analog input upper limit value as a floating point value.
- virtual const **Error** * **AinFltSetUpperLimit** (uint8 id, float value)
Set the analog input upper limit value as a floating point value.
- virtual const **Error** * **AinFltGetLowerLimit** (uint8 id, float &value)
Get the analog input lower limit value as a floating point value.
- virtual const **Error** * **AinFltSetLowerLimit** (uint8 id, float value)
Set the analog input lower limit value as a floating point value.
- virtual const **Error** * **AinFltGetUnsignedDelta** (uint8 id, float &value)
Get the analog input unsigned delta value as a floating point value.
- virtual const **Error** * **AinFltSetUnsignedDelta** (uint8 id, float value)
Set the analog input unsigned delta value as a floating point value.
- virtual const **Error** * **AinFltGetNegativeDelta** (uint8 id, float &value)
Get the analog input negative delta value as a floating point value.
- virtual const **Error** * **AinFltSetNegativeDelta** (uint8 id, float value)
Set the analog input negative delta value as a floating point value.
- virtual const **Error** * **AinFltGetPositiveDelta** (uint8 id, float &value)
Get the analog input positive delta value as a floating point value.
- virtual const **Error** * **AinFltSetPositiveDelta** (uint8 id, float value)
Set the analog input positive delta value as a floating point value.

Analog output control

If the module contains analog outputs, these methods may be used to configure and write to those outputs.

Most manufacturers support 16-bit access to analog inputs. Other input sizes are optional in the spec. and may or may not be available.

- virtual const **Error** * **Aout8GetCt** (uint8 &ct)
Return the number of 8-bit analog outputs available on this device.
- virtual const **Error** * **Aout8Write** (uint8 id, int8 value)
Write to an 8-bit analog output.
- virtual const **Error** * **Aout16GetCt** (uint8 &ct)
Return the number of 16-bit analog outputs available on this device.
- virtual const **Error** * **Aout16Write** (uint8 id, int16 value, bool viaSDO=false)
Write to a 16-bit analog output.
- virtual const **Error** * **Aout32GetCt** (uint8 &ct)
Return the number of 32-bit analog outputs available on this device.
- virtual const **Error** * **Aout32Write** (uint8 id, int32 value)
Write to a 32-bit analog output.
- virtual const **Error** * **AoutFltGetCt** (uint8 &ct)
Return the number of floating point analog outputs available on this device.
- virtual const **Error** * **AoutFltWrite** (uint8 id, float value)
Write to a floating point analog output.
- virtual const **Error** * **Aout32GetOffset** (uint8 id, int32 &value)
Get the analog output offset value as a 32-bit integer.

- virtual const [Error](#) * [Aout32SetOffset](#) (uint8 id, int32 value)
Set the analog output offset value as a 32-bit integer.
- virtual const [Error](#) * [Aout32GetScaling](#) (uint8 id, int32 &value)
Get the analog output scaling factor as a 32-bit integer.
- virtual const [Error](#) * [Aout32SetScaling](#) (uint8 id, int32 value)
Set the analog output scaling factor as a 32-bit integer.
- virtual const [Error](#) * [AoutFltGetOffset](#) (uint8 id, float &value)
Get the analog output offset value as a floating point value.
- virtual const [Error](#) * [AoutFltSetOffset](#) (uint8 id, float value)
Set the analog output offset value as a floating point value.
- virtual const [Error](#) * [AoutFltGetScaling](#) (uint8 id, float &value)
Get the analog output scaling factor as a floating point value.
- virtual const [Error](#) * [AoutFltSetScaling](#) (uint8 id, float value)
Set the analog output scaling factor as a floating point value.
- virtual const [Error](#) * [AoutGetErrMode](#) (uint8 id, bool &value)
Get the analog output error mode.
- virtual const [Error](#) * [AoutSetErrMode](#) (uint8 id, bool value)
Set the analog output error mode.
- virtual const [Error](#) * [Aout32GetErrValue](#) (uint8 id, int32 &value)
Get the analog output error value as a 32-bit integer.
- virtual const [Error](#) * [Aout32SetErrValue](#) (uint8 id, int32 value)
Set the analog output error value as a 32-bit integer.
- virtual const [Error](#) * [Aout16GetErrValue](#) (uint8 id, int16 &value)
Get the analog output error value as a 16-bit integer.
- virtual const [Error](#) * [Aout16SetErrValue](#) (uint8 id, int16 value)
Set the analog output error value as a 32-bit integer.
- virtual const [Error](#) * [AoutFltGetErrValue](#) (uint8 id, float &value)
Get the analog output error value as a floating point value.
- virtual const [Error](#) * [AoutFltSetErrValue](#) (uint8 id, float value)
Set the analog output error value as a floating point value.

Protected Member Functions

- const [Error](#) * [BitUpld](#) (uint16 base, uint16 id, bool &value)
Upload a setting for a single digital I/O pin.
- const [Error](#) * [BitDnld](#) (uint16 base, uint16 id, bool value)
Download a setting for a single digital I/O pin.
- const [Error](#) * [BitCount](#) (uint16 base, uint16 &ct)
Count the number of individual I/O pins available on the device.
- virtual void [PostIOEvent](#) (IOMODULE_EVENTS event)
Post an event condition to the I/O module's event map.

Protected Attributes

- [DigOutPDO](#) doutPDO
Default PDO used to transmit digital output info.

Additional Inherited Members

5.67.1 Detailed Description

Standard CANopen I/O module.

This class represents an I/O module device conforming to the DS401 CANopen specification. The class may be extended to provide additional manufacturer specific features.

Note that the CANopen standard defines a very large number of parameters that may be used with a standard I/O module. Of these, only a small subset are required by the spec. In practice, it seems that most of the major manufacturers of CANopen I/O modules only implement the minimum required by the spec. The result is that many of the optional functions have not been tested with real hardware due to the lack of availability. Please contact Copley Controls if you believe that you have found a problem with any of these functions.

For the typical I/O module, you can expect the following functionality to be supported based on the type of I/O the module supports:

Digital Inputs: Reading the inputs via [PDO](#) or [SDO](#) in groups of 8 should be supported. Other features are optional.

Digital Outputs: Writing to the outputs via [PDO](#) or [SDO](#) in groups of 8 should be supported. Other features are optional.

Analog Inputs: Reading 16-bit analog inputs via [PDO](#) or [SDO](#) is normally supported. Other input sizes and features are optional.

Analog Outputs: Writing 16-bit analog outputs via [PDO](#) or [SDO](#) is normally supported. Other output sizes and features are optional.

5.67.2 Constructor & Destructor Documentation

5.67.2.1 `IOModule (void)`

Default constructor for an I/O module.

Any object created using this constructor must be initialized by a call to [IOModule::Init](#) before it is used.

5.67.2.2 `IOModule (Network & net, int16 nodeId)`

Construct an [IOModule](#) object and initialize it using default settings.

Parameters

<i>net</i>	The Network object that this module is associated with.
<i>nodeID</i>	The node ID of the module on the network.

5.67.2.3 `IOModule (Network & net, int16 nodeId, IOModuleSettings & settings)`

Construct an [IOModule](#) object and initialize it using custom settings.

Parameters

<i>net</i>	The Network object that this module is associated with.
------------	---

<i>nodeID</i>	The node ID of the module on the network.
<i>settings</i>	The settings to use when configuring the module

5.67.3 Member Function Documentation

5.67.3.1 `virtual const Error* Ain16GetCt (uint8 & ct) [inline],[virtual]`

Return the number of 16-bit analog inputs available on this device.

Parameters

<i>ct</i>	The count is returned here. Zero is returned on error.
-----------	--

Returns

A pointer to an error object, or NULL on success

5.67.3.2 `virtual const Error* Ain16GetLowerLimit (uint8 id, int16 & value) [inline],[virtual]`

Get the analog input lower limit value as a 16-bit integer.

The lower limit defines the value at which an interrupt will be generated if it is enabled.

Parameters

<i>id</i>	The analog input channel ID
<i>value</i>	The value is returned here.

Returns

A pointer to an error object, or NULL on success

5.67.3.3 `virtual const Error* Ain16GetNegativeDelta (uint8 id, int16 & value) [inline],[virtual]`

Get the analog input negative delta value as a 16-bit integer.

The negative delta defines the amount of change at which an interrupt will be generated if it is enabled.

Parameters

<i>id</i>	The analog input channel ID
<i>value</i>	The value is returned here.

Returns

A pointer to an error object, or NULL on success

5.67.3.4 `virtual const Error* Ain16GetPositiveDelta (uint8 id, int16 & value) [inline],[virtual]`

Get the analog input positive delta value as a 16-bit integer.

The positive delta defines the amount of change at which an interrupt will be generated if it is enabled.

Parameters

<i>id</i>	The analog input channel ID
<i>value</i>	The value is returned here.

Returns

A pointer to an error object, or NULL on success

5.67.3.5 `virtual const Error* Ain16GetUnsignedDelta (uint8 id, int16 & value) [inline],[virtual]`

Get the analog input unsigned delta value as a 16-bit integer.

The unsigned delta defines the amount of change at which an interrupt will be generated if it is enabled.

Parameters

<i>id</i>	The analog input channel ID
<i>value</i>	The value is returned here.

Returns

A pointer to an error object, or NULL on success

5.67.3.6 `virtual const Error* Ain16GetUpperLimit (uint8 id, int16 & value) [inline],[virtual]`

Get the analog input upper limit value as a 16-bit integer.

The upper limit defines the value at which an interrupt will be generated if it is enabled.

Parameters

<i>id</i>	The analog input channel ID
<i>value</i>	The value is returned here.

Returns

A pointer to an error object, or NULL on success

5.67.3.7 `const Error * Ain16Read (uint8 id, int16 & value, bool viaSDO = false) [virtual]`

Read a 16-bit analog input.

Parameters

<i>id</i>	The analog input channel ID
<i>value</i>	The analog input value
<i>viaSDO</i>	If true, read the input using SDO transfers. If false (default) use the most recently received PDO data if this input is mapped to a transmit PDO and the PDO is active.

Returns

A pointer to an error object, or NULL on success

5.67.3.8 `virtual const Error* Ain16SetLowerLimit (uint8 id, int16 value) [inline],[virtual]`

Set the analog input lower limit value as a 16-bit integer.

The lower limit defines the value at which an interrupt will be generated if it is enabled.

Parameters

<i>id</i>	The analog input channel ID
<i>value</i>	The value to be set.

Returns

A pointer to an error object, or NULL on success

5.67.3.9 `virtual const Error* Ain16SetNegativeDelta (uint8 id, int16 value) [inline],[virtual]`

Set the analog input negative delta value as a 16-bit integer.

The negative delta defines the amount of change at which an interrupt will be generated if it is enabled.

Parameters

<i>id</i>	The analog input channel ID
<i>value</i>	The value to be set.

Returns

A pointer to an error object, or NULL on success

5.67.3.10 `virtual const Error* Ain16SetPositiveDelta (uint8 id, int16 value) [inline],[virtual]`

Set the analog input positive delta value as a 16-bit integer.

The positive delta defines the amount of change at which an interrupt will be generated if it is enabled.

Parameters

<i>id</i>	The analog input channel ID
<i>value</i>	The value to be set.

Returns

A pointer to an error object, or NULL on success

5.67.3.11 `virtual const Error* Ain16SetUnsignedDelta (uint8 id, int16 value) [inline],[virtual]`

Set the analog input unsigned delta value as a 16-bit integer.

The unsigned delta defines the amount of change at which an interrupt will be generated if it is enabled.

Parameters

<i>id</i>	The analog input channel ID
<i>value</i>	The value to be set.

Returns

A pointer to an error object, or NULL on success

5.67.3.12 `virtual const Error* Ain16SetUpperLimit (uint8 id, int16 value) [inline],[virtual]`

Set the analog input upper limit value as a 16-bit integer.

The upper limit defines the value at which an interrupt will be generated if it is enabled.

Parameters

<i>id</i>	The analog input channel ID
<i>value</i>	The value to be set.

Returns

A pointer to an error object, or NULL on success

5.67.3.13 `virtual const Error* Ain32GetCt (uint8 & ct) [inline],[virtual]`

Return the number of 32-bit analog inputs available on this device.

Parameters

<i>ct</i>	The count is returned here. Zero is returned on error.
-----------	--

Returns

A pointer to an error object, or NULL on success

5.67.3.14 `virtual const Error* Ain32GetLowerLimit (uint8 id, int32 & value) [inline],[virtual]`

Get the analog input lower limit value as a 32-bit integer.

The lower limit defines the value at which an interrupt will be generated if it is enabled.

Parameters

<i>id</i>	The analog input channel ID
<i>value</i>	The value is returned here.

Returns

A pointer to an error object, or NULL on success

5.67.3.15 `virtual const Error* Ain32GetNegativeDelta (uint8 id, int32 & value) [inline],[virtual]`

Get the analog input negative delta value as a 32-bit integer.

The negative delta defines the amount of change at which an interrupt will be generated if it is enabled.

Parameters

<i>id</i>	The analog input channel ID
<i>value</i>	The value is returned here.

Returns

A pointer to an error object, or NULL on success

5.67.3.16 `virtual const Error* Ain32GetOffset (uint8 id, int32 & value)` `[inline],[virtual]`

Get the analog input offset value as a 32-bit integer.

Parameters

<i>id</i>	The analog input channel ID
<i>value</i>	The value is returned here.

Returns

A pointer to an error object, or NULL on success

5.67.3.17 `virtual const Error* Ain32GetPositiveDelta (uint8 id, int32 & value)` `[inline],[virtual]`

Get the analog input positive delta value as a 32-bit integer.

The positive delta defines the amount of change at which an interrupt will be generated if it is enabled.

Parameters

<i>id</i>	The analog input channel ID
<i>value</i>	The value is returned here.

Returns

A pointer to an error object, or NULL on success

5.67.3.18 `virtual const Error* Ain32GetScaling (uint8 id, int32 & value)` `[inline],[virtual]`

Get the analog input scaling factor as a 32-bit integer.

Parameters

<i>id</i>	The analog input channel ID
<i>value</i>	The value is returned here.

Returns

A pointer to an error object, or NULL on success

5.67.3.19 `virtual const Error* Ain32GetUnsignedDelta (uint8 id, int32 & value)` `[inline],[virtual]`

Get the analog input unsigned delta value as a 32-bit integer.

The unsigned delta defines the amount of change at which an interrupt will be generated if it is enabled.

Parameters

<i>id</i>	The analog input channel ID
<i>value</i>	The value is returned here.

Returns

A pointer to an error object, or NULL on success

5.67.3.20 `virtual const Error* Ain32GetUpperLimit (uint8 id, int32 & value)` `[inline],[virtual]`

Get the analog input upper limit value as a 32-bit integer.

The upper limit defines the value at which an interrupt will be generated if it is enabled.

Parameters

<i>id</i>	The analog input channel ID
<i>value</i>	The value is returned here.

Returns

A pointer to an error object, or NULL on success

5.67.3.21 `virtual const Error* Ain32Read (uint8 id, int32 & value)` `[inline],[virtual]`

Read a 32-bit analog input.

Parameters

<i>id</i>	The analog input channel ID
<i>value</i>	The analog input value

Returns

A pointer to an error object, or NULL on success

5.67.3.22 `virtual const Error* Ain32SetLowerLimit (uint8 id, int32 value)` `[inline],[virtual]`

Set the analog input lower limit value as a 32-bit integer.

The lower limit defines the value at which an interrupt will be generated if it is enabled.

Parameters

<i>id</i>	The analog input channel ID
<i>value</i>	The value to be set.

Returns

A pointer to an error object, or NULL on success

5.67.3.23 `virtual const Error* Ain32SetNegativeDelta (uint8 id, int32 value) [inline],[virtual]`

Set the analog input negative delta value as a 32-bit integer.

The negative delta defines the amount of change at which an interrupt will be generated if it is enabled.

Parameters

<i>id</i>	The analog input channel ID
<i>value</i>	The value to be set.

Returns

A pointer to an error object, or NULL on success

5.67.3.24 `virtual const Error* Ain32SetOffset (uint8 id, int32 value) [inline],[virtual]`

Set the analog input offset value as a 32-bit integer.

Parameters

<i>id</i>	The analog input channel ID
<i>value</i>	The value to be set.

Returns

A pointer to an error object, or NULL on success

5.67.3.25 `virtual const Error* Ain32SetPositiveDelta (uint8 id, int32 value) [inline],[virtual]`

Set the analog input positive delta value as a 32-bit integer.

The positive delta defines the amount of change at which an interrupt will be generated if it is enabled.

Parameters

<i>id</i>	The analog input channel ID
<i>value</i>	The value to be set.

Returns

A pointer to an error object, or NULL on success

5.67.3.26 `virtual const Error* Ain32SetScaling (uint8 id, int32 value) [inline],[virtual]`

Set the analog input scaling factor as a 32-bit integer.

Parameters

<i>id</i>	The analog input channel ID
<i>value</i>	The value to be set.

Returns

A pointer to an error object, or NULL on success

5.67.3.27 `virtual const Error* Ain32SetUnsignedDelta (uint8 id, int32 value) [inline],[virtual]`

Set the analog input unsigned delta value as a 32-bit integer.

The unsigned delta defines the amount of change at which an interrupt will be generated if it is enabled.

Parameters

<i>id</i>	The analog input channel ID
<i>value</i>	The value to be set.

Returns

A pointer to an error object, or NULL on success

5.67.3.28 `virtual const Error* Ain32SetUpperLimit (uint8 id, int32 value) [inline],[virtual]`

Set the analog input upper limit value as a 32-bit integer.

The upper limit defines the value at which an interrupt will be generated if it is enabled.

Parameters

<i>id</i>	The analog input channel ID
<i>value</i>	The value to be set.

Returns

A pointer to an error object, or NULL on success

5.67.3.29 `virtual const Error* Ain8GetCt (uint8 & ct) [inline],[virtual]`

Return the number of 8-bit analog inputs available on this device.

Parameters

<i>ct</i>	The count is returned here. Zero is returned on error.
-----------	--

Returns

A pointer to an error object, or NULL on success

5.67.3.30 `virtual const Error* Ain8Read (uint8 id, int8 & value) [inline],[virtual]`

Read an 8-bit analog input.

Parameters

<i>id</i>	The analog input channel ID
<i>value</i>	The analog input value

Returns

A pointer to an error object, or NULL on success

5.67.3.31 `virtual const Error* AinFItGetCt (uint8 & ct) [inline],[virtual]`

Return the number of floating point analog inputs available on this device.

Parameters

<i>ct</i>	The count is returned here. Zero is returned on error.
-----------	--

Returns

A pointer to an error object, or NULL on success

5.67.3.32 `virtual const Error* AinFitGetLowerLimit (uint8 id, float & value) [inline],[virtual]`

Get the analog input lower limit value as a floating point value.

The lower limit defines the value at which an interrupt will be generated if it is enabled.

Parameters

<i>id</i>	The analog input channel ID
<i>value</i>	The value is returned here.

Returns

A pointer to an error object, or NULL on success

5.67.3.33 `virtual const Error* AinFitGetNegativeDelta (uint8 id, float & value) [inline],[virtual]`

Get the analog input negative delta value as a floating point value.

The negative delta defines the amount of change at which an interrupt will be generated if it is enabled.

Parameters

<i>id</i>	The analog input channel ID
<i>value</i>	The value is returned here.

Returns

A pointer to an error object, or NULL on success

5.67.3.34 `virtual const Error* AinFitGetOffset (uint8 id, float & value) [inline],[virtual]`

Get the analog input offset value as a floating point value.

Parameters

<i>id</i>	The analog input channel ID
<i>value</i>	The value is returned here.

Returns

A pointer to an error object, or NULL on success

5.67.3.35 `virtual const Error* AinFitGetPositiveDelta (uint8 id, float & value) [inline],[virtual]`

Get the analog input positive delta value as a floating point value.

The positive delta defines the amount of change at which an interrupt will be generated if it is enabled.

Parameters

<i>id</i>	The analog input channel ID
<i>value</i>	The value is returned here.

Returns

A pointer to an error object, or NULL on success

5.67.3.36 `virtual const Error* AinFitGetScaling (uint8 id, float & value)` `[inline],[virtual]`

Get the analog input scaling factor as a floating point value.

Parameters

<i>id</i>	The analog input channel ID
<i>value</i>	The value is returned here.

Returns

A pointer to an error object, or NULL on success

5.67.3.37 `virtual const Error* AinFitGetUnsignedDelta (uint8 id, float & value)` `[inline],[virtual]`

Get the analog input unsigned delta value as a floating point value.

The unsigned delta defines the amount of change at which an interrupt will be generated if it is enabled.

Parameters

<i>id</i>	The analog input channel ID
<i>value</i>	The value is returned here.

Returns

A pointer to an error object, or NULL on success

5.67.3.38 `virtual const Error* AinFitGetUpperLimit (uint8 id, float & value)` `[inline],[virtual]`

Get the analog input upper limit value as a floating point value.

The upper limit defines the value at which an interrupt will be generated if it is enabled.

Parameters

<i>id</i>	The analog input channel ID
<i>value</i>	The value is returned here.

Returns

A pointer to an error object, or NULL on success

5.67.3.39 `virtual const Error* AinFitRead (uint8 id, float & value)` `[inline],[virtual]`

Read a floating point analog input.

Parameters

<i>id</i>	The analog input channel ID
<i>value</i>	The analog input value

Returns

A pointer to an error object, or NULL on success

5.67.3.40 `virtual const Error* AinFitSetLowerLimit (uint8 id, float value) [inline],[virtual]`

Set the analog input lower limit value as a floating point value.

The lower limit defines the value at which an interrupt will be generated if it is enabled.

Parameters

<i>id</i>	The analog input channel ID
<i>value</i>	The value to be set.

Returns

A pointer to an error object, or NULL on success

5.67.3.41 `virtual const Error* AinFitSetNegativeDelta (uint8 id, float value) [inline],[virtual]`

Set the analog input negative delta value as a floating point value.

The negative delta defines the amount of change at which an interrupt will be generated if it is enabled.

Parameters

<i>id</i>	The analog input channel ID
<i>value</i>	The value to be set.

Returns

A pointer to an error object, or NULL on success

5.67.3.42 `virtual const Error* AinFitSetOffset (uint8 id, float value) [inline],[virtual]`

Set the analog input offset value as a floating point value.

Parameters

<i>id</i>	The analog input channel ID
<i>value</i>	The value to be set.

Returns

A pointer to an error object, or NULL on success

5.67.3.43 `virtual const Error* AinFitSetPositiveDelta (uint8 id, float value) [inline],[virtual]`

Set the analog input positive delta value as a floating point value.

The positive delta defines the amount of change at which an interrupt will be generated if it is enabled.

Parameters

<i>id</i>	The analog input channel ID
<i>value</i>	The value to be set.

Returns

A pointer to an error object, or NULL on success

5.67.3.44 `virtual const Error* AinFitSetScaling (uint8 id, float value) [inline],[virtual]`

Set the analog input scaling factor as a floating point value.

Parameters

<i>id</i>	The analog input channel ID
<i>value</i>	The value to be set.

Returns

A pointer to an error object, or NULL on success

5.67.3.45 `virtual const Error* AinFitSetUnsignedDelta (uint8 id, float value) [inline],[virtual]`

Set the analog input unsigned delta value as a floating point value.

The unsigned delta defines the amount of change at which an interrupt will be generated if it is enabled.

Parameters

<i>id</i>	The analog input channel ID
<i>value</i>	The value to be set.

Returns

A pointer to an error object, or NULL on success

5.67.3.46 `virtual const Error* AinFitSetUpperLimit (uint8 id, float value) [inline],[virtual]`

Set the analog input upper limit value as a floating point value.

The upper limit defines the value at which an interrupt will be generated if it is enabled.

Parameters

<i>id</i>	The analog input channel ID
<i>value</i>	The value to be set.

Returns

A pointer to an error object, or NULL on success

5.67.3.47 `virtual const Error* AinGetIntEna (bool & value) [inline],[virtual]`

Get the current setting of the global interrupt enable for analog inputs.

A return value of true indicates that interrupts are enabled, false disabled.

Parameters

<i>value</i>	The current interrupt enable setting is returned here.
--------------	--

Returns

A pointer to an error object, or NULL on success

5.67.3.48 `virtual const Error* AinGetIntSource (uint8 id, uint32 & value) [inline],[virtual]`

Get the analog input interrupt source.

This variable may be used to determine which analog input has produced an interrupt. There are eight banks of interrupt source registers, each of which covers 32 analog inputs in its 32 bits. Bank 0 identifies analog inputs 0 to 31, Bank 1 identifies analog inputs 32 to 63, etc. The bit associated with the analog input generating the latest interrupt will be set in the value returned by this read. Reading this variable causes all its bit to be automatically reset.

Parameters

<i>id</i>	The bank number to read (0 to 7)
<i>value</i>	The value is returned here.

Returns

A pointer to an error object, or NULL on success

5.67.3.49 `virtual const Error* AinGetTrigType (uint8 id, IO_AIN_TRIG_TYPE & value) [inline],[virtual]`

Get the analog input trigger type associated with the input channel.

Parameters

<i>id</i>	The analog input channel ID
<i>value</i>	The value is returned here.

Returns

A pointer to an error object, or NULL on success

5.67.3.50 `virtual const Error* AinSetIntEna (bool value) [inline],[virtual]`

Set the current setting of the global interrupt enable for analog inputs.

Setting this parameter to true enables interrupts, false disables.

Parameters

<i>value</i>	The interrupt enable setting.
--------------	-------------------------------

Returns

A pointer to an error object, or NULL on success

5.67.3.51 virtual const Error* AinSetTrigType (uint8 *id*, IO_AIN_TRIG_TYPE *value*) [inline],[virtual]

Set the analog input trigger type associated with the input channel.

Parameters

<i>id</i>	The analog input channel ID
<i>value</i>	The value to set

Returns

A pointer to an error object, or NULL on success

5.67.3.52 `virtual const Error* Aout16GetCt (uint8 & ct) [inline],[virtual]`

Return the number of 16-bit analog outputs available on this device.

Parameters

<i>ct</i>	The count is returned here. Zero is returned on error.
-----------	--

Returns

A pointer to an error object, or NULL on success

5.67.3.53 `virtual const Error* Aout16GetErrValue (uint8 id, int16 & value) [inline],[virtual]`

Get the analog output error value as a 16-bit integer.

The error value is the value that the analog output will assume on device error, if it's error mode is set to true.

Parameters

<i>id</i>	The analog output channel ID
<i>value</i>	The value is returned here.

Returns

A pointer to an error object, or NULL on success

5.67.3.54 `virtual const Error* Aout16SetErrValue (uint8 id, int16 value) [inline],[virtual]`

Set the analog output error value as a 32-bit integer.

The error value is the value that the analog output will assume on device error, if it's error mode is set to true.

Parameters

<i>id</i>	The analog output channel ID
<i>value</i>	The value to be set.

Returns

A pointer to an error object, or NULL on success

5.67.3.55 `const Error * Aout16Write (uint8 id, int16 value, bool viaSDO = false) [virtual]`

Write to a 16-bit analog output.

Since 16-bit outputs are mapped to the default PDOs of the I/O module, these outputs may be written using either PDOs or SDOs.

Parameters

<i>id</i>	The analog input channel ID
<i>value</i>	The value to write.
<i>viaSDO</i>	If true, the outputs will be written using SDO messages. If false (default), then a PDO will be used if possible.

Returns

A pointer to an error object, or NULL on success

5.67.3.56 `virtual const Error* Aout32GetCt (uint8 & ct) [inline],[virtual]`

Return the number of 32-bit analog outputs available on this device.

Parameters

<i>ct</i>	The count is returned here. Zero is returned on error.
-----------	--

Returns

A pointer to an error object, or NULL on success

5.67.3.57 `virtual const Error* Aout32GetErrValue (uint8 id, int32 & value) [inline],[virtual]`

Get the analog output error value as a 32-bit integer.

The error value is the value that the analog output will assume on device error, if it's error mode is set to true.

Parameters

<i>id</i>	The analog output channel ID
<i>value</i>	The value is returned here.

Returns

A pointer to an error object, or NULL on success

5.67.3.58 `virtual const Error* Aout32GetOffset (uint8 id, int32 & value) [inline],[virtual]`

Get the analog output offset value as a 32-bit integer.

Parameters

<i>id</i>	The analog output channel ID
<i>value</i>	The value is returned here.

Returns

A pointer to an error object, or NULL on success

5.67.3.59 `virtual const Error* Aout32GetScaling (uint8 id, int32 & value) [inline],[virtual]`

Get the analog output scaling factor as a 32-bit integer.

Parameters

<i>id</i>	The analog output channel ID
<i>value</i>	The value is returned here.

Returns

A pointer to an error object, or NULL on success

5.67.3.60 `virtual const Error* Aout32SetErrValue (uint8 id, int32 value) [inline],[virtual]`

Set the analog output error value as a 32-bit integer.

The error value is the value that the analog output will assume on device error, if it's error mode is set to true.

Parameters

<i>id</i>	The analog output channel ID
<i>value</i>	The value to be set.

Returns

A pointer to an error object, or NULL on success

5.67.3.61 `virtual const Error* Aout32SetOffset (uint8 id, int32 value) [inline],[virtual]`

Set the analog output offset value as a 32-bit integer.

Parameters

<i>id</i>	The analog output channel ID
<i>value</i>	The value to be set.

Returns

A pointer to an error object, or NULL on success

5.67.3.62 `virtual const Error* Aout32SetScaling (uint8 id, int32 value) [inline],[virtual]`

Set the analog output scaling factor as a 32-bit integer.

Parameters

<i>id</i>	The analog output channel ID
<i>value</i>	The value to be set.

Returns

A pointer to an error object, or NULL on success

5.67.3.63 `virtual const Error* Aout32Write (uint8 id, int32 value) [inline],[virtual]`

Write to a 32-bit analog output.

Parameters

<i>id</i>	The analog input channel ID
<i>value</i>	The value to write.

Returns

A pointer to an error object, or NULL on success

5.67.3.64 `virtual const Error* Aout8GetCt (uint8 & ct) [inline],[virtual]`

Return the number of 8-bit analog outputs available on this device.

Parameters

<i>ct</i>	The count is returned here. Zero is returned on error.
-----------	--

Returns

A pointer to an error object, or NULL on success

5.67.3.65 `virtual const Error* Aout8Write (uint8 id, int8 value) [inline],[virtual]`

Write to an 8-bit analog output.

Parameters

<i>id</i>	The analog input channel ID
<i>value</i>	The value to write.

Returns

A pointer to an error object, or NULL on success

5.67.3.66 `virtual const Error* AoutFitGetCt (uint8 & ct) [inline],[virtual]`

Return the number of floating point analog outputs available on this device.

Parameters

<i>ct</i>	The count is returned here. Zero is returned on error.
-----------	--

Returns

A pointer to an error object, or NULL on success

5.67.3.67 `virtual const Error* AoutFitGetErrValue (uint8 id, float & value) [inline],[virtual]`

Get the analog output error value as a floating point value.

The error value is the value that the analog output will assume on device error, if it's error mode is set to true.

Parameters

<i>id</i>	The analog output channel ID
<i>value</i>	The value is returned here.

Returns

A pointer to an error object, or NULL on success

5.67.3.68 `virtual const Error* AoutFitGetOffset (uint8 id, float & value) [inline],[virtual]`

Get the analog output offset value as a floating point value.

Parameters

<i>id</i>	The analog output channel ID
<i>value</i>	The value is returned here.

Returns

A pointer to an error object, or NULL on success

5.67.3.69 `virtual const Error* AoutFitGetScaling (uint8 id, float & value) [inline],[virtual]`

Get the analog output scaling factor as a floating point value.

Parameters

<i>id</i>	The analog output channel ID
<i>value</i>	The value is returned here.

Returns

A pointer to an error object, or NULL on success

5.67.3.70 `virtual const Error* AoutFitSetErrValue (uint8 id, float value) [inline],[virtual]`

Set the analog output error value as a floating point value.

The error value is the value that the analog output will assume on device error, if its error mode is set to true.

Parameters

<i>id</i>	The analog output channel ID
<i>value</i>	The value to be set.

Returns

A pointer to an error object, or NULL on success

5.67.3.71 `virtual const Error* AoutFitSetOffset (uint8 id, float value) [inline],[virtual]`

Set the analog output offset value as a floating point value.

Parameters

<i>id</i>	The analog output channel ID
<i>value</i>	The value to be set.

Returns

A pointer to an error object, or NULL on success

5.67.3.72 `virtual const Error* AoutFitSetScaling (uint8 id, float value) [inline],[virtual]`

Set the analog output scaling factor as a floating point value.

Parameters

<i>id</i>	The analog output channel ID
<i>value</i>	The value to be set.

Returns

A pointer to an error object, or NULL on success

5.67.3.73 `virtual const Error* AoutFitWrite (uint8 id, float value) [inline],[virtual]`

Write to a floating point analog output.

Parameters

<i>id</i>	The analog input channel ID
<i>value</i>	The value to write.

Returns

A pointer to an error object, or NULL on success

5.67.3.74 `virtual const Error* AoutGetErrMode (uint8 id, bool & value) [inline],[virtual]`

Get the analog output error mode.

If the error mode is true, then the analog output will change its value to the programmed error value in the case of a device failure. If false, a device failure will not cause a change in the analog output value.

Parameters

<i>id</i>	The analog output channel ID
<i>value</i>	The value is returned here.

Returns

A pointer to an error object, or NULL on success

5.67.3.75 `virtual const Error* AoutSetErrMode (uint8 id, bool value) [inline],[virtual]`

Set the analog output error mode.

If the error mode is true, then the analog output will change it's value to the programmed error value in the case of a device failure. If false, a device failure will not cause a change in the analog output value.

Parameters

<i>id</i>	The analog output channel ID
<i>value</i>	The value to be set.

Returns

A pointer to an error object, or NULL on success

5.67.3.76 `const Error* BitCount (uint16 base, uint16 & ct) [inline],[protected]`

Count the number of individual I/O pins available on the device.

Parameters

<i>base</i>	The base index for the object dictionary
<i>ct</i>	The count is returned here

Returns

A pointer to an error object, or NULL on success

5.67.3.77 `const Error* BitDnld (uint16 base, uint16 id, bool value) [inline],[protected]`

Download a setting for a single digital I/O pin.

The object dictionary index/sub-index is calculated from the pin ID and a passed base address.

Parameters

<i>base</i>	The object dictionary base index for this parameter
<i>id</i>	The I/O pin ID. Must range from 0 to 1024
<i>value</i>	The boolean value is passed here.

Returns

A pointer to an error object, or NULL on success

5.67.3.78 `const Error* BitUpld (uint16 base, uint16 id, bool & value) [inline],[protected]`

Upload a setting for a single digital I/O pin.

The object dictionary entry is calculated based on the pin ID and the base object dictionary ID passed.

Parameters

<i>base</i>	The object dictionary base index for this parameter
<i>id</i>	The I/O pin ID. Must range from 0 to 1024
<i>value</i>	The boolean value is returned here

Returns

A pointer to an error object, or NULL on success

5.67.3.79 `virtual const Error* Din16GetCt (uint8 & ct) [inline],[virtual]`

Return the number of 16-bit groups of inputs available on this device.

Parameters

<i>ct</i>	The count is returned here. Zero is returned on error.
-----------	--

Returns

A pointer to an error object, or NULL on success

5.67.3.80 `virtual const Error* Din16GetFilt (uint8 id, uint16 & value) [inline],[virtual]`

Get the current filter constant settings for a group of 16 digital inputs.

For each input in the group, a value of 1 enables the filter, 0 disables.

Parameters

<i>id</i>	Identifies which group of inputs to read.
<i>value</i>	The current filter setting of the input lines is returned here.

Returns

A pointer to an error object, or NULL on success

5.67.3.81 `virtual const Error* Din16GetMaskAny (uint8 id, uint16 & value) [inline],[virtual]`

Get the 'any transition' interrupt mask settings for a group of 16 digital inputs.

For each input in the group, a value of 1 enables interrupts on any change, and a value of 0 disables the interrupt.

Parameters

<i>id</i>	Identifies which group of inputs to read.
<i>value</i>	The current interrupt mask setting of the input lines.

Returns

A pointer to an error object, or NULL on success

5.67.3.82 `virtual const Error* Din16GetMaskHigh2Low (uint8 id, uint16 & value) [inline],[virtual]`

Get the 'high to low' interrupt mask settings for a group of 16 digital inputs.

For each input in the group, a value of 1 enables interrupts on a high to low transition, and a value of 0 disables the interrupt.

Parameters

<i>id</i>	Identifies which group of inputs to read.
<i>value</i>	The current interrupt mask setting of the input lines.

Returns

A pointer to an error object, or NULL on success

5.67.3.83 `virtual const Error* Din16GetMaskLow2High (uint8 id, uint16 & value) [inline],[virtual]`

Get the 'low to high' interrupt mask settings for a group of 16 digital inputs.

For each input in the group, a value of 1 enables interrupts on a low to high transition, and a value of 0 disables the interrupt.

Parameters

<i>id</i>	Identifies which group of inputs to read.
<i>value</i>	The current interrupt mask setting of the input lines.

Returns

A pointer to an error object, or NULL on success

5.67.3.84 `virtual const Error* Din16GetPol (uint8 id, uint16 & value) [inline],[virtual]`

Get the current polarity settings for a group of 16 digital inputs.

For each input in the group, a value of 1 enables inversion and 0 disables.

Parameters

<i>id</i>	Identifies which group of inputs to read.
<i>value</i>	The current polarity setting of the input lines is returned here.

Returns

A pointer to an error object, or NULL on success

5.67.3.85 `const Error * Din16Read (uint8 id, uint16 & value, bool viaSDO = false) [virtual]`

Read a group of 16 digital inputs.

Parameters

<i>id</i>	Identifies which group of 16 inputs to read.
<i>value</i>	The value of the 16 input lines is returned here.
<i>viaSDO</i>	If true, read the inputs using SDO transfers. If false (default) use the most recently received PDO data if this input group is mapped to a transmit PDO and the PDO is active.

Returns

A pointer to an error object, or NULL on success

5.67.3.86 `virtual const Error* Din16SetFilt (uint8 id, uint16 value) [inline],[virtual]`

Set the current filter constant setting for a group of 16 digital inputs.

For each input in the group, a value of 1 enables the filter, 0 disables.

Parameters

<i>id</i>	Identifies which group of inputs to effect.
<i>value</i>	The new filter setting of the input lines.

Returns

A pointer to an error object, or NULL on success

5.67.3.87 `virtual const Error* Din16SetMaskAny (uint8 id, uint16 value) [inline],[virtual]`

Set the 'any transition' interrupt mask settings for a group of 16 digital inputs.

For each input in the group, a value of 1 enables interrupts on any transition, and a value of 0 disables.

Parameters

<i>id</i>	Identifies which group of inputs to effect.
<i>value</i>	The new interrupt mask value.

Returns

A pointer to an error object, or NULL on success

5.67.3.88 `virtual const Error* Din16SetMaskHigh2Low (uint8 id, uint16 value) [inline],[virtual]`

Set the 'high to low' interrupt mask settings for a group of 16 digital inputs.

For each input in the group, a value of 1 enables interrupts on high to low transitions, and a value of 0 disables.

Parameters

<i>id</i>	Identifies which group of inputs to effect.
-----------	---

<i>value</i>	The new interrupt mask value.
--------------	-------------------------------

Returns

A pointer to an error object, or NULL on success

5.67.3.89 `virtual const Error* Din16SetMaskLow2High (uint8 id, uint16 value) [inline],[virtual]`

Set the 'low to high' interrupt mask settings for a group of 16 digital inputs.

For each input in the group, a value of 1 enables interrupts on low to high transitions, and a value of 0 disables.

Parameters

<i>id</i>	Identifies which group of inputs to effect.
<i>value</i>	The new interrupt mask value.

Returns

A pointer to an error object, or NULL on success

5.67.3.90 `virtual const Error* Din16SetPol (uint8 id, uint16 value) [inline],[virtual]`

Set the current polarity setting for a group of 16 digital inputs.

For each input in the group, a value of 1 enables inversion and 0 disables.

Parameters

<i>id</i>	Identifies which group of inputs to effect.
<i>value</i>	The new polarity setting of the input lines.

Returns

A pointer to an error object, or NULL on success

5.67.3.91 `virtual const Error* Din32GetCt (uint8 & ct) [inline],[virtual]`

Return the number of 32-bit groups of inputs available on this device.

Parameters

<i>ct</i>	The count is returned here. Zero is returned on error.
-----------	--

Returns

A pointer to an error object, or NULL on success

5.67.3.92 `virtual const Error* Din32GetFilt (uint8 id, uint32 & value) [inline],[virtual]`

Get the current filter constant settings for a group of 32 digital inputs.

For each input in the group, a value of 1 enables the filter, 0 disables.

Parameters

<i>id</i>	Identifies which group of inputs to read.
<i>value</i>	The current filter setting of the input lines is returned here.

Returns

A pointer to an error object, or NULL on success

5.67.3.93 `virtual const Error* Din32GetMaskAny (uint8 id, uint32 & value) [inline],[virtual]`

Get the 'any transition' interrupt mask settings for a group of 32 digital inputs.

For each input in the group, a value of 1 enables interrupts on any change, and a value of 0 disables the interrupt.

Parameters

<i>id</i>	Identifies which group of inputs to read.
<i>value</i>	The current interrupt mask setting of the input lines.

Returns

A pointer to an error object, or NULL on success

5.67.3.94 `virtual const Error* Din32GetMaskHigh2Low (uint8 id, uint32 & value) [inline],[virtual]`

Get the 'high to low' interrupt mask settings for a group of 32 digital inputs.

For each input in the group, a value of 1 enables interrupts on a high to low transition, and a value of 0 disables the interrupt.

Parameters

<i>id</i>	Identifies which group of inputs to read.
<i>value</i>	The current interrupt mask setting of the input lines.

Returns

A pointer to an error object, or NULL on success

5.67.3.95 `virtual const Error* Din32GetMaskLow2High (uint8 id, uint32 & value) [inline],[virtual]`

Get the 'low to high' interrupt mask settings for a group of 32 digital inputs.

For each input in the group, a value of 1 enables interrupts on a low to high transition, and a value of 0 disables the interrupt.

Parameters

<i>id</i>	Identifies which group of inputs to read.
-----------	---

<i>value</i>	The current interrupt mask setting of the input lines.
--------------	--

Returns

A pointer to an error object, or NULL on success

5.67.3.96 `virtual const Error* Din32GetPol (uint8 id, uint32 & value) [inline],[virtual]`

Get the current polarity settings for a group of 32 digital inputs.

For each input in the group, a value of 1 enables inversion and 0 disables.

Parameters

<i>id</i>	Identifies which group of inputs to read.
<i>value</i>	The current polarity setting of the input lines is returned here.

Returns

A pointer to an error object, or NULL on success

5.67.3.97 `const Error * Din32Read (uint8 id, uint32 & value, bool viaSDO = false) [virtual]`

Read a group of 32 digital inputs.

Parameters

<i>id</i>	Identifies which group of 32 inputs to read.
<i>value</i>	The value of the 32 input lines is returned here.
<i>viaSDO</i>	If true, read the inputs using SDO transfers. If false (default) use the most recently received PDO data if this input group is mapped to a transmit PDO and the PDO is active.

Returns

A pointer to an error object, or NULL on success

5.67.3.98 `virtual const Error* Din32SetFilt (uint8 id, uint32 value) [inline],[virtual]`

Set the current filter constant setting for a group of 32 digital inputs.

For each input in the group, a value of 1 enables the filter, 0 disables.

Parameters

<i>id</i>	Identifies which group of inputs to effect.
<i>value</i>	The new filter setting of the input lines.

Returns

A pointer to an error object, or NULL on success

5.67.3.99 `virtual const Error* Din32SetMaskAny (uint8 id, uint32 value) [inline],[virtual]`

Set the 'any transition' interrupt mask settings for a group of 32 digital inputs.

For each input in the group, a value of 1 enables interrupts on any transition, and a value of 0 disables.

Parameters

<i>id</i>	Identifies which group of inputs to effect.
<i>value</i>	The new interrupt mask value.

Returns

A pointer to an error object, or NULL on success

5.67.3.100 `virtual const Error* Din32SetMaskHigh2Low (uint8 id, uint32 value) [inline],[virtual]`

Set the 'high to low' interrupt mask settings for a group of 32 digital inputs.

For each input in the group, a value of 1 enables interrupts on high to low transitions, and a value of 0 disables.

Parameters

<i>id</i>	Identifies which group of inputs to effect.
<i>value</i>	The new interrupt mask value.

Returns

A pointer to an error object, or NULL on success

5.67.3.101 `virtual const Error* Din32SetMaskLow2High (uint8 id, uint32 value) [inline],[virtual]`

Set the 'low to high' interrupt mask settings for a group of 32 digital inputs.

For each input in the group, a value of 1 enables interrupts on low to high transitions, and a value of 0 disables.

Parameters

<i>id</i>	Identifies which group of inputs to effect.
<i>value</i>	The new interrupt mask value.

Returns

A pointer to an error object, or NULL on success

5.67.3.102 `virtual const Error* Din32SetPol (uint8 id, uint32 value) [inline],[virtual]`

Set the current polarity setting for a group of 32 digital inputs.

For each input in the group, a value of 1 enables inversion and 0 disables.

Parameters

<i>id</i>	Identifies which group of inputs to effect.
<i>value</i>	The new polarity setting of the input lines.

Returns

A pointer to an error object, or NULL on success

5.67.3.103 `virtual const Error* Din8GetCt (uint8 & ct) [inline],[virtual]`

Return the number of 8-bit groups of inputs available on this device.

Parameters

<i>ct</i>	The count is returned here. Zero is returned on error.
-----------	--

Returns

A pointer to an error object, or NULL on success

5.67.3.104 `virtual const Error* Din8GetFilt (uint8 id, uint8 & value) [inline],[virtual]`

Get the current filter constant settings for a group of 8 digital inputs.

For each input in the group, a value of 1 enables the filter, 0 disables.

Parameters

<i>id</i>	Identifies which group of 8 inputs to read.
<i>value</i>	The current filter setting of the 8 input lines is returned here.

Returns

A pointer to an error object, or NULL on success

5.67.3.105 `virtual const Error* Din8GetMaskAny (uint8 id, uint8 & value) [inline],[virtual]`

Get the 'any transition' interrupt mask settings for a group of 8 digital inputs.

For each input in the group, a value of 1 enables interrupts on any change, and a value of 0 disables the interrupt.

Parameters

<i>id</i>	Identifies which group of 8 inputs to read.
<i>value</i>	The current interrupt mask setting of the 8 input lines.

Returns

A pointer to an error object, or NULL on success

5.67.3.106 `virtual const Error* Din8GetMaskHigh2Low (uint8 id, uint8 & value) [inline],[virtual]`

Get the 'high to low' interrupt mask settings for a group of 8 digital inputs.

For each input in the group, a value of 1 enables interrupts on a high to low transition, and a value of 0 disables the interrupt.

Parameters

<i>id</i>	Identifies which group of 8 inputs to read.
<i>value</i>	The current interrupt mask setting of the 8 input lines.

Returns

A pointer to an error object, or NULL on success

5.67.3.107 `virtual const Error* Din8GetMaskLow2High (uint8 id, uint8 & value) [inline],[virtual]`

Get the 'low to high' interrupt mask settings for a group of 8 digital inputs.

For each input in the group, a value of 1 enables interrupts on a low to high transition, and a value of 0 disables the interrupt.

Parameters

<i>id</i>	Identifies which group of 8 inputs to read.
<i>value</i>	The current interrupt mask setting of the 8 input lines.

Returns

A pointer to an error object, or NULL on success

5.67.3.108 `virtual const Error* Din8GetPol (uint8 id, uint8 & value) [inline],[virtual]`

Get the current polarity settings for a group of 8 digital inputs.

For each input in the group, a value of 1 enables inversion and 0 disables.

Parameters

<i>id</i>	Identifies which group of 8 inputs to read.
<i>value</i>	The current polarity setting of the 8 input lines is returned here.

Returns

A pointer to an error object, or NULL on success

5.67.3.109 `const Error * Din8Read (uint8 id, uint8 & value, bool viaSDO = false) [virtual]`

Read a group of 8 digital inputs.

Parameters

<i>id</i>	Identifies which group of 8 inputs to read.
<i>value</i>	The value of the 8 input lines is returned here.
<i>viaSDO</i>	If true, read the inputs using SDO transfers. If false (default) use the most recently received PDO data if this input group is mapped to a transmit PDO and the PDO is active.

Returns

A pointer to an error object, or NULL on success

5.67.3.110 `virtual const Error* Din8SetFilt (uint8 id, uint8 value) [inline],[virtual]`

Set the current filter constant setting for a group of 8 digital inputs.

For each input in the group, a value of 1 enables the filter, 0 disables.

Parameters

<i>id</i>	Identifies which group of 8 inputs to effect.
<i>value</i>	The new filter setting of the 8 input lines.

Returns

A pointer to an error object, or NULL on success

5.67.3.111 `virtual const Error* Din8SetMaskAny (uint8 id, uint8 value) [inline],[virtual]`

Set the 'any transition' interrupt mask settings for a group of 8 digital inputs.

For each input in the group, a value of 1 enables interrupts on any transition, and a value of 0 disables.

Parameters

<i>id</i>	Identifies which group of 8 inputs to effect.
<i>value</i>	The new interrupt mask value.

Returns

A pointer to an error object, or NULL on success

5.67.3.112 `virtual const Error* Din8SetMaskHigh2Low (uint8 id, uint8 value) [inline],[virtual]`

Set the 'high to low' interrupt mask settings for a group of 8 digital inputs.

For each input in the group, a value of 1 enables interrupts on high to low transitions, and a value of 0 disables.

Parameters

<i>id</i>	Identifies which group of 8 inputs to effect.
<i>value</i>	The new interrupt mask value.

Returns

A pointer to an error object, or NULL on success

5.67.3.113 `virtual const Error* Din8SetMaskLow2High (uint8 id, uint8 value) [inline],[virtual]`

Set the 'low to high' interrupt mask settings for a group of 8 digital inputs.

For each input in the group, a value of 1 enables interrupts on low to high transitions, and a value of 0 disables.

Parameters

<i>id</i>	Identifies which group of 8 inputs to effect.
<i>value</i>	The new interrupt mask value.

Returns

A pointer to an error object, or NULL on success

5.67.3.114 `virtual const Error* Din8SetPol (uint8 id, uint8 value) [inline],[virtual]`

Set the current polarity setting for a group of 8 digital inputs.

For each input in the group, a value of 1 enables inversion and 0 disables.

Parameters

<i>id</i>	Identifies which group of 8 inputs to effect.
<i>value</i>	The new polarity setting of the 8 input lines.

Returns

A pointer to an error object, or NULL on success

5.67.3.115 `virtual const Error* DinGetCt (uint16 & ct) [inline],[virtual]`

Return the number of individual inputs available on this device.

Parameters

<i>ct</i>	The count is returned here. Zero is returned on error.
-----------	--

Returns

A pointer to an error object, or NULL on success

5.67.3.116 `virtual const Error* DinGetFilt (uint16 id, bool & value) [inline],[virtual]`

Get the current filter constant setting for a digital input.

The filter constant is enabled if true, disabled if false.

Parameters

<i>id</i>	Identifies the digital input.
<i>value</i>	The current filter setting.

Returns

A pointer to an error object, or NULL on success

5.67.3.117 `virtual const Error* DinGetIntEna (bool & value) [inline],[virtual]`

Get the current setting of the global interrupt enable for digital inputs.

A return value of true indicates that interrupts are enabled, false disabled.

Parameters

<i>value</i>	The current interrupt enable setting is returned here.
--------------	--

Returns

A pointer to an error object, or NULL on success

5.67.3.118 `virtual const Error* DinGetMaskAny (uint16 id, bool & value) [inline],[virtual]`

Get the 'any transition' interrupt mask settings for a digital input.

If true, any transition on the input will generate an interrupt.

Parameters

<i>id</i>	Identifies the digital input.
<i>value</i>	The current interrupt mask setting

Returns

A pointer to an error object, or NULL on success

5.67.3.119 `virtual const Error* DinGetMaskHigh2Low (uint16 id, bool & value) [inline],[virtual]`

Get the 'high to low' interrupt mask settings for a digital input.

If true, a high to low transition on the input will generate an interrupt.

Parameters

<i>id</i>	Identifies the digital input.
<i>value</i>	The current interrupt mask setting

Returns

A pointer to an error object, or NULL on success

5.67.3.120 `virtual const Error* DinGetMaskLow2High (uint16 id, bool & value) [inline],[virtual]`

Get the 'low to high' interrupt mask settings for a digital input.

If true, a low to high transition on the input will generate an interrupt.

Parameters

<i>id</i>	Identifies the digital input.
<i>value</i>	The current interrupt mask setting

Returns

A pointer to an error object, or NULL on success

5.67.3.121 `virtual const Error* DinGetPol (uint16 id, bool & value) [inline],[virtual]`

Get the current polarity settings for a digital input.

Polarity inversion is enabled if true, disabled if false.

Parameters

<i>id</i>	Identifies the digital input.
<i>value</i>	The current polarity setting.

Returns

A pointer to an error object, or NULL on success

5.67.3.122 `const Error* DinRead (uint16 id, bool & value, bool viaSDO = false) [virtual]`

Read a single digital input.

Parameters

<i>id</i>	Identifies the digital input to read.
<i>value</i>	The value of the input.
<i>viaSDO</i>	If true, an SDO will be used to read the input pin. If false (default), the latest value returned via PDO will be returned, if available.

Returns

A pointer to an error object, or NULL on success

5.67.3.123 `virtual const Error* DinSetFilt (uint16 id, bool value) [inline],[virtual]`

Set the current filter constant setting for a digital input.

The filter constant is enabled if true, disabled if false.

Parameters

<i>id</i>	Identifies the digital input.
<i>value</i>	The new filter setting.

Returns

A pointer to an error object, or NULL on success

5.67.3.124 `virtual const Error* DinSetIntEna (bool value) [inline],[virtual]`

Set the current setting of the global interrupt enable for digital inputs.

Setting this parameter to true enables interrupts, false disables.

Parameters

<i>value</i>	The interrupt enable setting.
--------------	-------------------------------

Returns

A pointer to an error object, or NULL on success

5.67.3.125 `virtual const Error* DinSetMaskAny (uint16 id, bool value) [inline],[virtual]`

Set the 'any transition' interrupt mask settings for a digital input.

If true, any transition on the input will generate an interrupt.

Parameters

<i>id</i>	Identifies the digital input.
<i>value</i>	The new interrupt mask setting.

Returns

A pointer to an error object, or NULL on success

5.67.3.126 `virtual const Error* DinSetMaskHigh2Low (uint16 id, bool value) [inline],[virtual]`

Set the 'high to low' interrupt mask settings for a digital input.

If true, a high to low transition on the input will generate an interrupt.

Parameters

<i>id</i>	Identifies the digital input.
<i>value</i>	The new interrupt mask setting.

Returns

A pointer to an error object, or NULL on success

5.67.3.127 `virtual const Error* DinSetMaskLow2High (uint16 id, bool value) [inline],[virtual]`

Set the 'low to high' interrupt mask settings for a digital input.

If true, a low to high transition on the input will generate an interrupt.

Parameters

<i>id</i>	Identifies the digital input.
<i>value</i>	The new interrupt mask setting.

Returns

A pointer to an error object, or NULL on success

5.67.3.128 `virtual const Error* DinSetPol (uint16 id, bool value) [inline],[virtual]`

Set the current polarity setting for a digital input.

Polarity inversion is enabled if true, disabled if false.

Parameters

<i>id</i>	Identifies the digital input.
<i>value</i>	The new polarity setting.

Returns

A pointer to an error object, or NULL on success

5.67.3.129 `virtual const Error* Dout16GetCt (uint8 & ct) [inline],[virtual]`

Return the number of 16-bit groups of outputs available on this device.

Parameters

<i>ct</i>	The count is returned here. Zero is returned on error.
-----------	--

Returns

A pointer to an error object, or NULL on success

5.67.3.130 `virtual const Error* Dout16GetErrMode (uint8 id, uint16 & value) [inline],[virtual]`

Get the current error mode settings for a group of 16 digital outputs.

For each output in the group, a value of 1 will cause the output to take it's programmed error value on a device failure. Setting the mode to 0 will cause the output to hold it's programmed value on failure.

Parameters

<i>id</i>	Identifies which group of outputs to read.
<i>value</i>	The current error mode setting of the output lines is returned here.

Returns

A pointer to an error object, or NULL on success

5.67.3.131 `virtual const Error* Dout16GetErrValue (uint8 id, uint16 & value) [inline],[virtual]`

Get the current error value settings for a group of 16 digital outputs.

Error values define the state of the output if a device failure occurs. The error value will only be set for those output pins which have an error mode set to 1. Those with error mode set to zero will not be changed by a device failure.

Parameters

<i>id</i>	Identifies which group of outputs to read.
<i>value</i>	The current error value setting of the output lines is returned here.

Returns

A pointer to an error object, or NULL on success

5.67.3.132 `virtual const Error* Dout16GetFilt (uint8 id, uint16 & value) [inline],[virtual]`

Get the current filter constant settings for a group of 16 digital outputs.

For each output in the group, a value of 1 enables the filter, 0 disables.

Parameters

<i>id</i>	Identifies which group of outputs to read.
<i>value</i>	The current filter setting of the output lines is returned here.

Returns

A pointer to an error object, or NULL on success

5.67.3.133 `virtual const Error* Dout16GetPol (uint8 id, uint16 & value) [inline],[virtual]`

Get the current polarity settings for a group of 16 digital outputs.

For each output in the group, a value of 1 enables inversion and 0 disables.

Parameters

<i>id</i>	Identifies which group of outputs to read.
<i>value</i>	The current polarity setting of the output lines is returned here.

Returns

A pointer to an error object, or NULL on success

5.67.3.134 `const Error* Dout16Read (uint8 id, uint16 & value) [inline]`

Read back the last value written to this bank of 16 digital outputs.

Parameters

<i>id</i>	Identifies which group of outputs to read.
<i>value</i>	The current state of the output lines is returned here.

Returns

A pointer to an error object, or NULL on success

5.67.3.135 `virtual const Error* Dout16SetErrMode (uint8 id, uint16 value) [inline],[virtual]`

Set the current error mode settings for a group of 16 digital outputs.

For each output in the group, a value of 1 will cause the output to take it's programmed error value on a device failure. Setting the mode to 0 will cause the output to hold it's programmed value on failure.

Parameters

<i>id</i>	Identifies which group of outputs to effect.
<i>value</i>	The new error mode setting of the output lines.

Returns

A pointer to an error object, or NULL on success

5.67.3.136 `virtual const Error* Dout16SetErrValue (uint8 id, uint16 value) [inline],[virtual]`

Set the current error value settings for a group of 16 digital outputs.

[Error](#) values define the state of the output if a device failure occurs. The error value will only be set for those output pins which have an error mode set to 1. Those with error mode set to zero will not be changed by a device failure.

Parameters

<i>id</i>	Identifies which group of outputs to effect.
<i>value</i>	The new error value setting of the output lines.

Returns

A pointer to an error object, or NULL on success

5.67.3.137 `virtual const Error* Dout16SetFilt (uint8 id, uint16 value) [inline],[virtual]`

Set the current filter constant setting for a group of 16 digital outputs.

For each output in the group, a value of 1 enables the filter, 0 disables.

Parameters

<i>id</i>	Identifies which group of outputs to effect.
<i>value</i>	The new filter setting of the output lines.

Returns

A pointer to an error object, or NULL on success

5.67.3.138 `virtual const Error* Dout16SetPol (uint8 id, uint16 value) [inline],[virtual]`

Set the current polarity setting for a group of 16 digital outputs.

For each output in the group, a value of 1 enables inversion and 0 disables.

Parameters

<i>id</i>	Identifies which group of outputs to effect.
<i>value</i>	The new polarity setting of the output lines.

Returns

A pointer to an error object, or NULL on success

5.67.3.139 `const Error * Dout16Write (uint8 id, uint16 value, bool viaSDO = false) [virtual]`

Write a group of 16 digital outputs.

The outputs may be written either by [SDO](#) or by [PDO](#). The [PDO](#) method is faster since it only requires a single message to be sent. [SDO](#) transfers additionally require a response from the module.

If a [PDO](#) transfer is requested, but is not possible because the module is not in an operational state, or because the output block isn't mapped to the [PDO](#), then an [SDO](#) transfer will be used.

Parameters

<i>id</i>	Identifies which group of outputs to write.
<i>value</i>	The new value of the output lines.
<i>viaSDO</i>	If true, the outputs will be written using SDO messages. If false (default), then a PDO will be used if possible.

Returns

A pointer to an error object, or NULL on success

5.67.3.140 `virtual const Error* Dout32GetCt (uint8 & ct) [inline],[virtual]`

Return the number of 32-bit groups of outputs available on this device.

Parameters

<i>ct</i>	The count is returned here. Zero is returned on error.
-----------	--

Returns

A pointer to an error object, or NULL on success

5.67.3.141 `virtual const Error* Dout32GetErrMode (uint8 id, uint32 & value) [inline],[virtual]`

Get the current error mode settings for a group of 32 digital outputs.

For each output in the group, a value of 1 will cause the output to take it's programmed error value on a device failure. Setting the mode to 0 will cause the output to hold it's programmed value on failure.

Parameters

<i>id</i>	Identifies which group of outputs to read.
<i>value</i>	The current error mode setting of the output lines is returned here.

Returns

A pointer to an error object, or NULL on success

5.67.3.142 `virtual const Error* Dout32GetErrValue (uint8 id, uint32 & value) [inline],[virtual]`

Get the current error value settings for a group of 32 digital outputs.

[Error](#) values define the state of the output if a device failure occurs. The error value will only be set for those output pins which have an error mode set to 1. Those with error mode set to zero will not be changed by a device failure.

Parameters

<i>id</i>	Identifies which group of outputs to read.
<i>value</i>	The current error value setting of the output lines is returned here.

Returns

A pointer to an error object, or NULL on success

5.67.3.143 `virtual const Error* Dout32GetFilt (uint8 id, uint32 & value) [inline],[virtual]`

Get the current filter constant settings for a group of 32 digital outputs.

For each output in the group, a value of 1 enables the filter, 0 disables.

Parameters

<i>id</i>	Identifies which group of outputs to read.
<i>value</i>	The current filter setting of the output lines is returned here.

Returns

A pointer to an error object, or NULL on success

5.67.3.144 `virtual const Error* Dout32GetPol (uint8 id, uint32 & value) [inline],[virtual]`

Get the current polarity settings for a group of 32 digital outputs.

For each output in the group, a value of 1 enables inversion and 0 disables.

Parameters

<i>id</i>	Identifies which group of outputs to read.
<i>value</i>	The current polarity setting of the output lines is returned here.

Returns

A pointer to an error object, or NULL on success

5.67.3.145 `const Error* Dout32Read (uint8 id, uint32 & value) [inline]`

Read back the last value written to this bank of 32 digital outputs.

Parameters

<i>id</i>	Identifies which group of outputs to read.
<i>value</i>	The current state of the output lines is returned here.

Returns

A pointer to an error object, or NULL on success

5.67.3.146 `virtual const Error* Dout32SetErrMode (uint8 id, uint32 value) [inline],[virtual]`

Set the current error mode settings for a group of 32 digital outputs.

For each output in the group, a value of 1 will cause the output to take it's programmed error value on a device failure. Setting the mode to 0 will cause the output to hold it's programmed value on failure.

Parameters

<i>id</i>	Identifies which group of outputs to effect.
<i>value</i>	The new error mode setting of the output lines.

Returns

A pointer to an error object, or NULL on success

5.67.3.147 `virtual const Error* Dout32SetErrValue (uint8 id, uint32 value) [inline],[virtual]`

Set the current error value settings for a group of 32 digital outputs.

Error values define the state of the output if a device failure occurs. The error value will only be set for those output pins which have an error mode set to 1. Those with error mode set to zero will not be changed by a device failure.

Parameters

<i>id</i>	Identifies which group of outputs to effect.
<i>value</i>	The new error value setting of the output lines.

Returns

A pointer to an error object, or NULL on success

5.67.3.148 `virtual const Error* Dout32SetFilt (uint8 id, uint32 value) [inline],[virtual]`

Set the current filter constant setting for a group of 32 digital outputs.

For each output in the group, a value of 1 enables the filter, 0 disables.

Parameters

<i>id</i>	Identifies which group of outputs to effect.
<i>value</i>	The new filter setting of the output lines.

Returns

A pointer to an error object, or NULL on success

5.67.3.149 `virtual const Error* Dout32SetPol (uint8 id, uint32 value) [inline],[virtual]`

Set the current polarity setting for a group of 32 digital outputs.

For each output in the group, a value of 1 enables inversion and 0 disables.

Parameters

<i>id</i>	Identifies which group of outputs to effect.
<i>value</i>	The new polarity setting of the output lines.

Returns

A pointer to an error object, or NULL on success

5.67.3.150 `const Error * Dout32Write (uint8 id, uint32 value, bool viaSDO = false) [virtual]`

Write a group of 32 digital outputs.

The outputs may be written either by [SDO](#) or by [PDO](#). The [PDO](#) method is faster since it only requires a single message to be sent. [SDO](#) transfers additionally require a response from the module.

If a [PDO](#) transfer is requested, but is not possible because the module is not in an operational state, or because the output block isn't mapped to the [PDO](#), then an [SDO](#) transfer will be used.

Parameters

<i>id</i>	Identifies which group of outputs to write.
<i>value</i>	The new value of the output lines.
<i>viaSDO</i>	If true, the outputs will be written using SDO messages. If false (default), then a PDO will be used if possible.

Returns

A pointer to an error object, or NULL on success

5.67.3.151 `virtual const Error* Dout8GetCt (uint8 & ct) [inline],[virtual]`

Return the number of 8-bit groups of outputs available on this device.

Parameters

<i>ct</i>	The count is returned here. Zero is returned on error.
-----------	--

Returns

A pointer to an error object, or NULL on success

5.67.3.152 `virtual const Error* Dout8GetErrMode (uint8 id, uint8 & value) [inline],[virtual]`

Get the current error mode settings for a group of 8 digital outputs.

For each output in the group, a value of 1 will cause the output to take it's programmed error value on a device failure. Setting the mode to 0 will cause the output to hold it's programmed value on failure.

Parameters

<i>id</i>	Identifies which group of outputs to read.
<i>value</i>	The current error mode setting of the output lines is returned here.

Returns

A pointer to an error object, or NULL on success

5.67.3.153 `virtual const Error* Dout8GetErrValue (uint8 id, uint8 & value) [inline],[virtual]`

Get the current error value settings for a group of 8 digital outputs.

[Error](#) values define the state of the output if a device failure occurs. The error value will only be set for those output pins which have an error mode set to 1. Those with error mode set to zero will not be changed by a device failure.

Parameters

<i>id</i>	Identifies which group of outputs to read.
<i>value</i>	The current error value setting of the output lines is returned here.

Returns

A pointer to an error object, or NULL on success

5.67.3.154 `virtual const Error* Dout8GetFilt (uint8 id, uint8 & value) [inline],[virtual]`

Get the current filter constant settings for a group of 8 digital outputs.

For each output in the group, a value of 1 enables the filter, 0 disables.

Parameters

<i>id</i>	Identifies which group of outputs to read.
<i>value</i>	The current filter setting of the output lines is returned here.

Returns

A pointer to an error object, or NULL on success

5.67.3.155 `virtual const Error* Dout8GetPol (uint8 id, uint8 & value) [inline],[virtual]`

Get the current polarity settings for a group of 8 digital outputs.

For each output in the group, a value of 1 enables inversion and 0 disables.

Parameters

<i>id</i>	Identifies which group of outputs to read.
<i>value</i>	The current polarity setting of the output lines is returned here.

Returns

A pointer to an error object, or NULL on success

5.67.3.156 `const Error* Dout8Read (uint8 id, uint8 & value) [inline]`

Read back the last value written to this bank of 8 digital outputs.

Parameters

<i>id</i>	Identifies which group of outputs to read.
<i>value</i>	The current state of the output lines is returned here.

Returns

A pointer to an error object, or NULL on success

5.67.3.157 `virtual const Error* Dout8SetErrMode (uint8 id, uint8 value) [inline],[virtual]`

Set the current error mode settings for a group of 8 digital outputs.

For each output in the group, a value of 1 will cause the output to take it's programmed error value on a device failure. Setting the mode to 0 will cause the output to hold it's programmed value on failure.

Parameters

<i>id</i>	Identifies which group of outputs to effect.
<i>value</i>	The new error mode setting of the output lines.

Returns

A pointer to an error object, or NULL on success

5.67.3.158 `virtual const Error* Dout8SetErrValue (uint8 id, uint8 value) [inline],[virtual]`

Set the current error value settings for a group of 8 digital outputs.

Error values define the state of the output if a device failure occurs. The error value will only be set for those output pins which have an error mode set to 1. Those with error mode set to zero will not be changed by a device failure.

Parameters

<i>id</i>	Identifies which group of outputs to effect.
<i>value</i>	The new error value setting of the output lines.

Returns

A pointer to an error object, or NULL on success

5.67.3.159 `virtual const Error* Dout8SetFilt (uint8 id, uint8 value) [inline],[virtual]`

Set the current filter constant setting for a group of 8 digital outputs.

For each output in the group, a value of 1 enables the filter, 0 disables.

Parameters

<i>id</i>	Identifies which group of outputs to effect.
-----------	--

<i>value</i>	The new filter setting of the output lines.
--------------	---

Returns

A pointer to an error object, or NULL on success

5.67.3.160 `virtual const Error* Dout8SetPol (uint8 id, uint8 value) [inline],[virtual]`

Set the current polarity setting for a group of 8 digital outputs.

For each output in the group, a value of 1 enables inversion and 0 disables.

Parameters

<i>id</i>	Identifies which group of outputs to effect.
<i>value</i>	The new polarity setting of the output lines.

Returns

A pointer to an error object, or NULL on success

5.67.3.161 `const Error * Dout8Write (uint8 id, uint8 value, bool viaSDO = false)`

Write a group of 8 digital outputs.

The outputs may be written either by [SDO](#) or by [PDO](#). The [PDO](#) method is faster since it only requires a single message to be sent. [SDO](#) transfers additionally require a response from the module.

If a [PDO](#) transfer is requested, but is not possible because the module is not in an operational state, or because the output block isn't mapped to the [PDO](#), then an [SDO](#) transfer will be used.

Parameters

<i>id</i>	Identifies which group of outputs to write.
<i>value</i>	The new value of the output lines.
<i>viaSDO</i>	If true, the outputs will be written using SDO messages. If false (default), then a PDO will be used if possible.

Returns

A pointer to an error object, or NULL on success

5.67.3.162 `virtual const Error* DoutGetCt (uint16 & ct) [inline],[virtual]`

Return the number of individual outputs available on this device.

Parameters

<i>ct</i>	The count is returned here. Zero is returned on error.
-----------	--

Returns

A pointer to an error object, or NULL on success

5.67.3.163 `virtual const Error* DoutGetErrMode (uint16 id, bool & value) [inline],[virtual]`

Get the current error mode setting for an individual digital output.

A value of true will cause the output to take it's programmed error value on a device failure. Setting the mode to false will cause the output to hold it's programmed value on failure.

Parameters

<i>id</i>	Identifies the output to read.
<i>value</i>	The current error mode setting of the output line is returned here.

Returns

A pointer to an error object, or NULL on success

5.67.3.164 `virtual const Error* DoutGetErrValue (uint16 id, bool & value) [inline],[virtual]`

Get the current error value setting for an individual digital output.

Error values define the state of the output if a device failure occurs. The error value will only be set for those output pins which have an error mode set to true. Those with error mode set to false will not be changed by a device failure.

Parameters

<i>id</i>	Identifies the output to read.
<i>value</i>	The current error value setting of the output line is returned here.

Returns

A pointer to an error object, or NULL on success

5.67.3.165 `virtual const Error* DoutGetFilt (uint16 id, bool & value) [inline],[virtual]`

Get the current filter constant setting for an individual digital output.

A value of true enables the filter, false disables.

Parameters

<i>id</i>	Identifies the output to read.
<i>value</i>	The current filter setting of the output line is returned here.

Returns

A pointer to an error object, or NULL on success

5.67.3.166 `virtual const Error* DoutGetPol (uint16 id, bool & value) [inline],[virtual]`

Get the current polarity setting for an individual digital output.

A value of true enables inversion and false disables.

Parameters

<i>id</i>	Identifies the output to read.
<i>value</i>	The current polarity setting of the output line is returned here.

Returns

A pointer to an error object, or NULL on success

5.67.3.167 `virtual const Error* DoutSetErrMode (uint16 id, bool value) [inline],[virtual]`

Set the current error mode setting for an individual digital output.

A value of true will cause the output to take it's programmed error value on a device failure. Setting the mode to false will cause the output to hold it's programmed value on failure.

Parameters

<i>id</i>	Identifies which digital output to effect.
<i>value</i>	The new error mode setting of the output line.

Returns

A pointer to an error object, or NULL on success

5.67.3.168 `virtual const Error* DoutSetErrValue (uint16 id, bool value) [inline],[virtual]`

Set the current error value setting for an individual digital output.

Error values define the state of the output if a device failure occurs. The error value will only be set for those output pins which have an error mode set to true. Those with error mode set to false will not be changed by a device failure.

Parameters

<i>id</i>	Identifies which digital output to effect.
<i>value</i>	The new error value setting of the output line.

Returns

A pointer to an error object, or NULL on success

5.67.3.169 `virtual const Error* DoutSetFilt (uint16 id, bool value) [inline],[virtual]`

Set the current filter constant setting for an individual digital output.

A value of true enables the filter, false disables.

Parameters

<i>id</i>	Identifies which digital output to effect.
-----------	--

<i>value</i>	The new filter setting of the output line.
--------------	--

Returns

A pointer to an error object, or NULL on success

5.67.3.170 `virtual const Error* DoutSetPol (uint16 id, bool value) [inline],[virtual]`

Set the current polarity setting for an individual digital output.

A value of true enables inversion and false disables.

Parameters

<i>id</i>	Identifies which digital output to effect.
<i>value</i>	The new polarity setting of the output line.

Returns

A pointer to an error object, or NULL on success

5.67.3.171 `const Error * DoutWrite (uint16 id, bool value, bool viaSDO = false) [virtual]`

Write an individual digital output.

The output may be written either by [SDO](#) or by [PDO](#). The [PDO](#) method is faster since it only requires a single message to be sent. [SDO](#) transfers additionally require a response from the module.

If a [PDO](#) transfer is requested, but is not possible because the module is not in an operational state, or because the output isn't mapped to the [PDO](#), then an [SDO](#) transfer will be used.

Parameters

<i>id</i>	Identifies which output to write.
<i>value</i>	The new value of the output line.
<i>viaSDO</i>	If true, the outputs will be written using SDO messages. If false (default), then a PDO will be used if possible.

Returns

A pointer to an error object, or NULL on success

5.67.3.172 `const Error * Init (Network & net, int16 nodeID) [virtual]`

Initialize an I/O module using default settings.

This function associates the object with the CANopen network it will be used on.

Parameters

<i>net</i>	The Network object that this module is associated with.
<i>nodeID</i>	The node ID of the module on the network.

Returns

A pointer to an error object, or NULL on success

Reimplemented from [Node](#).

Reimplemented in [CopleyIO](#).

5.67.3.173 `const Error * Init (Network & net, int16 nodeID, IOModuleSettings & settings)` [virtual]

Initialize an I/O module using custom settings.

This function associates the object with the CANopen network it will be used on.

Parameters

<i>net</i>	The Network object that this module is associated with.
<i>nodeID</i>	The node ID of the module on the network.
<i>settings</i>	The settings to use when configuring the module

Returns

A pointer to an error object, or NULL on success

Reimplemented in [CopleyIO](#).

5.67.3.174 `virtual void PostIOEvent (IOMODULE_EVENTS event)` [inline],[protected],[virtual]

Post an event condition to the I/O module's event map.

This method is used internally by the various standard transmit PDOs when a new [PDO](#) message is received.

Parameters

<i>event</i>	The event bit(s) to post
--------------	--------------------------

5.67.3.175 `const Error * WaitIOEvent (IOMODULE_EVENTS event, Timeout timeout = -1)` [virtual]

Wait on an event associated with this I/O module.

The standard events are used to indicate that a new transmit [PDO](#) has been received. A thread may wait on such an event by calling this function.

Parameters

<i>event</i>	The event(s) to wait on. Multiple events may be ORed together and in this case this function will return when any of them occur.
--------------	--

<i>timeout</i>	The timeout for the wait (milliseconds). Negative values indicate that no timeout should be used (wait forever). The default value is -1.
----------------	---

Returns

A pointer to an error object, or NULL on success

5.67.3.176 `const Error * WaitIOEvent (Event & e, Timeout timeout, IOMODULE_EVENTS & match)` [virtual]

Wait for an event associated with this I/O module.

This function can be used to wait on any generic event associated with the I/O module.

Parameters

<i>e</i>	The event to wait on.
<i>timeout</i>	The timeout for the wait (milliseconds). If < 0, then wait forever.
<i>match</i>	Returns the matching event condition.

Returns

A pointer to an error object, or NULL on success.

The documentation for this class was generated from the following files:

- [CML_IO.h](#)
- [IOmodule.cpp](#)

5.68 IOModuleSettings Struct Reference

Standard CANopen I/O module settings.

Public Attributes

- [uint16 heartbeatPeriod](#)
The CANopen heartbeat protocol is one of two standard methods used to constantly watch for network or device problems.
- [uint16 heartbeatTimeout](#)
Additional time to wait before generating a heartbeat error (milliseconds) If the heartbeat protocol is used, then this value, combined with the heartbeatTime will determine how long the network master waits for the node's heartbeat message before it generates a heartbeat error.
- [uint16 guardTime](#)
Node guarding guard time (milliseconds)
- [uint8 lifeFactor](#)
Node guarding life time factor.
- [bool useStandardDinPDO](#)
Use the standard digital input PDO object.
- [bool useStandardDoutPDO](#)
Use the standard digital output PDO object.
- [bool useStandardAinPDO](#)
Use the standard analog input PDO objects.
- [bool useStandardAoutPDO](#)
Use the standard analog output PDO objects.

5.68.1 Detailed Description

Standard CANopen I/O module settings.

This structure may be passed to an I/O module object during initialization. It allows custom settings to be assigned to the module.

5.68.2 Member Data Documentation

5.68.2.1 uint16 guardTime

[Node](#) guarding guard time (milliseconds)

The CANopen node guarding protocol is a second method (the first being the heartbeat protocol) for devices on the network to watch for network problems. In this protocol, the master controller sends a request message out to the slave device at a specified interval. The slave device responds to this request with a message indicating its state.

The main difference between this protocol and the heartbeat protocol is that both the slave node and the master are able to recognize network errors. With the heartbeat protocol only the network master is able to identify network problems.

Note that only one of these two protocols can be active in a node device at any time. If the heartbeat period is non-zero, then the heartbeat protocol will be used.

This parameter gives the node guarding period for use with this node. This is the period between node guarding request messages sent by the master controller.

Note that both this parameter, and the life time factor must be non-zero for node guarding to be used.

Default 0 (ms)

5.68.2.2 uint16 heartbeatPeriod

The CANopen heartbeat protocol is one of two standard methods used to constantly watch for network or device problems.

When the heartbeat protocol is used, each device on the CANopen network transmits a 'heartbeat' message at a specified interval. The network master watches for these messages, and is able to detect a device error if its heartbeat message is not received within the expected time.

This parameter configures the heartbeat period (milliseconds) that will be used by this module to transmit its heartbeat message.

If this parameter is set to zero, then the heartbeat protocol is disabled on this node.

Default: zero (not used)

5.68.2.3 uint16 heartbeatTimeout

Additional time to wait before generating a heartbeat error (milliseconds) If the heartbeat protocol is used, then this value, combined with the heartbeatTime will determine how long the network master waits for the node's heartbeat message before it generates a heartbeat error.

Note that setting this to zero does not disable the heartbeat protocol. set the heartbeatPeriod value to zero to disable heartbeat.

Default 100 (ms)

5.68.2.4 uint8 lifeFactor

Node guarding life time factor.

When the node guarding protocol is used, this parameter is used by the slave device to determine how long to wait for a node guarding request from the master controller before signaling an error condition.

The life time factor is treated as a multiple of the guard time.

If this parameter and the node guard time are both non-zero, and the heartbeatTime is zero, then node guarding will be setup for the amplifier.

Default 3 (multiples of the guard time)

5.68.2.5 bool useStandardAinPDO

Use the standard analog input [PDO](#) objects.

If true (default) then up to three standard [PDO](#) objects will be configured to read the first 12 16-bit analog input pins when they generate events. If false, then these PDOs will not be configured.

5.68.2.6 bool useStandardAoutPDO

Use the standard analog output [PDO](#) objects.

If true (default) then up to three standard [PDO](#) objects will be configured to transmit the analog output data for up to 12 16-bit analog outputs. If false, then these PDOs will not be configured.

5.68.2.7 bool useStandardDinPDO

Use the standard digital input [PDO](#) object.

If true (default) then a standard [PDO](#) object will be configured to read up to 64 digital inputs any time one of them changes. If false, then this [PDO](#) will not be configured.

5.68.2.8 bool useStandardDoutPDO

Use the standard digital output [PDO](#) object.

If true (default) then a standard [PDO](#) object will be configured to transmit updated settings for the first 64 digital output pins when any of them are changed. If false, no such [PDO](#) will be configured.

The documentation for this struct was generated from the following file:

- [CML_IO.h](#)

5.69 IxxatCAN Class Reference

Ixxat specific CAN interface.

Inheritance diagram for IxxatCAN:

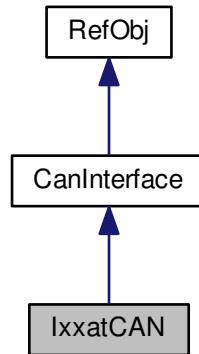

Collaboration diagram for IxxatCAN:

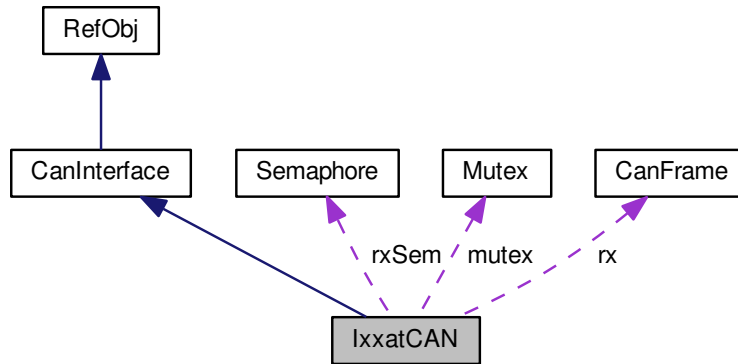

Public Member Functions

- `IxxatCAN` (void)
Construct a new Ixxat CAN interface object.
- `IxxatCAN` (const char *port)
Construct a new Ixxat CAN interface object for the specified port.
- virtual `~IxxatCAN` (void)
Destructor for Ixxat card.
- const `Error * Open` (void)

- Open the Ixxat CAN card.*

 - const [Error](#) * [Close](#) (void)

Close the CAN interface.
- const [Error](#) * [SetBaud](#) (int32 baud)

Set the CAN interface baud rate.
- void [rxInt](#) (int16 ct, void *frame)

Receive interrupt handler.

Protected Member Functions

- const [Error](#) * [RecvFrame](#) ([CanFrame](#) &frame, Timeout timeout)

Receive the next CAN frame.
- const [Error](#) * [XmitFrame](#) ([CanFrame](#) &frame, Timeout timeout)

Write a CAN frame to the CAN network.
- const [Error](#) * [ConvertError](#) (int err)

Convert error codes defined by the Vector CAN library into the standard error codes used by the motion library.

Protected Attributes

- int [open](#)
- tracks the state of the interface as open or closed.*
- [uint8 channel](#)
- Which CAN channel to use (on multi-channel boards).*
- [int32 baud](#)
- Holds a copy of the last baud rate set.*
- int [handle](#)
- File handle used to access the CAN channel.*

Additional Inherited Members

5.69.1 Detailed Description

Ixxat specific CAN interface.

This class extends the generic [CanInterface](#) class into a working interface for the Ixxat can device driver.

5.69.2 Constructor & Destructor Documentation

5.69.2.1 IxxatCAN (void)

Construct a new Ixxat CAN interface object.

This simply sets the default baud rate and marks the card as not open.

5.69.2.2 IxxatCAN (const char * port)

Construct a new Ixxat CAN interface object for the specified port.

The port name should be of the form CANx or IXXATx where x is the port number. The port numbers start at 0, so the first port would be identified by the port name CAN0.

Parameters

<i>port</i>	The port name string identifying the CAN device.
-------------	--

5.69.2.3 `~IxxatCAN(void)` [virtual]

Destructor for Ixxat card.

Closes the interface and unloads the library.

5.69.3 Member Function Documentation

5.69.3.1 `const Error * Close(void)` [virtual]

Close the CAN interface.

Returns

A pointer to an error object on failure, or NULL on success.

Reimplemented from [CanInterface](#).

5.69.3.2 `const Error * ConvertError(int err)` [protected]

Convert error codes defined by the Vector CAN library into the standard error codes used by the motion library.

Parameters

<i>err</i>	The Vector style status code
------------	------------------------------

Returns

A pointer to an error object, or NULL if no error is indicated

5.69.3.3 `const Error * Open(void)` [virtual]

Open the Ixxat CAN card.

The card should have been identified by setting it's name either in the constructor, or by using the method [CanInterface::SetName](#).

If no port name was set, then the default Ixxat card will be used.

If the port name is set to "select", then a dialog box will be shown allowing the card to be selected from any installed Ixxat cards.

Otherwise, the port name should be of the form "CANx" where x is the Ixxat hardware key number (i.e. CAN1 for hardware key 1).

Returns

A pointer to an error object on failure, or NULL on success.

Reimplemented from [CanInterface](#).

5.69.3.4 `const Error * RecvFrame (CanFrame & frame, Timeout timeout)` [protected],[virtual]

Receive the next CAN frame.

Parameters

<i>frame</i>	A reference to the frame object that will be filled by the read.
<i>timeout</i>	The timeout (ms) to wait for the frame. A timeout of 0 will return immediately if no data is available. A timeout of < 0 will wait forever.

Returns

A pointer to an error object on failure, or NULL on success.

Reimplemented from [CanInterface](#).

5.69.3.5 void rxInt (int16 ct, void * ptr)

Receive interrupt handler.

This is an internal function that should not be called except by the driver. It's used to add one or more CAN frames to the receive buffer when they are received.

Parameters

<i>ct</i>	The number of frames to add
<i>ptr</i>	Points to an array of ct VCI_CAN_OBJ structures.

5.69.3.6 const Error * SetBaud (int32 b) [virtual]

Set the CAN interface baud rate.

Parameters

<i>b</i>	The baud rate to set.
----------	-----------------------

Returns

A pointer to an error object on failure, or NULL on success.

Reimplemented from [CanInterface](#).

5.69.3.7 const Error * XmitFrame (CanFrame & frame, Timeout timeout) [protected],[virtual]

Write a CAN frame to the CAN network.

Parameters

<i>frame</i>	A reference to the frame to write.
<i>timeout</i>	The time to wait for the frame to be successfully sent. If the timeout is 0, the frame is written to the output queue and the function returns without waiting for it to be sent. If the timeout is <0 then the function will delay forever.

Returns

A pointer to an error object on failure, or NULL on success.

Reimplemented from [CanInterface](#).

5.69.4 Member Data Documentation

5.69.4.1 `uint8 channel` `[protected]`

Which CAN channel to use (on multi-channel boards).

For the moment this is always set to zero.

The documentation for this class was generated from the following files:

- [can_ixxat.h](#)
- [can_ixxat.cpp](#)

5.70 IxxatCANV3 Class Reference

Ixxat specific CAN interface.

Inheritance diagram for IxxatCANV3:

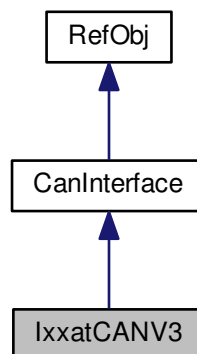

Collaboration diagram for IxxatCANV3:

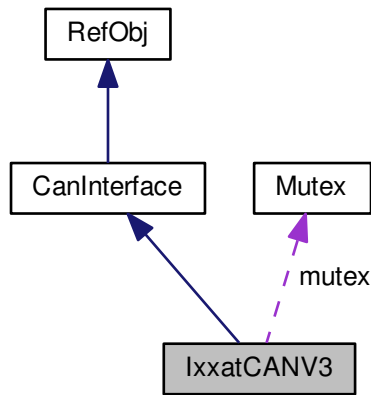

Public Member Functions

- const **Error** * **Open** (void)
Open the CAN interface.
- const **Error** * **Close** (void)
Close the CAN interface.
- const **Error** * **SetBaud** (int32 baud)
Set the CAN interface baud rate.

Protected Member Functions

- const **Error** * **RecvFrame** (CanFrame &frame, Timeout timeout)
Receive the next CAN frame.
- const **Error** * **XmitFrame** (CanFrame &frame, Timeout timeout)
Write a CAN frame to the CAN network.
- const **Error** * **ConvertError** (int err)
Convert error codes defined by the Vector CAN library into the standard error codes used by the motion library.

Protected Attributes

- int **open**
tracks the state of the interface as open or closed.
- uint8 **channel**
Which CAN channel to use (on multi-channel boards).
- int32 **baud**
Holds a copy of the last baud rate set.
- int **handle**
File handle used to access the CAN channel.

Additional Inherited Members

5.70.1 Detailed Description

Ixxat specific CAN interface.

This class extends the generic [CanInterface](#) class into a working interface for the Ixxat can device driver.

5.70.2 Member Function Documentation

5.70.2.1 `const Error * Close (void) [virtual]`

Close the CAN interface.

Returns

A pointer to an error object on failure, or NULL on success.

Reimplemented from [CanInterface](#).

5.70.2.2 `const Error * ConvertError (int err) [protected]`

Convert error codes defined by the Vector CAN library into the standard error codes used by the motion library.

Parameters

<i>err</i>	The Vector style status code
------------	------------------------------

Returns

A pointer to an error object, or NULL if no error is indicated

5.70.2.3 `const Error * Open (void) [virtual]`

Open the CAN interface.

Returns

A valid CAN error object

Reimplemented from [CanInterface](#).

5.70.2.4 `const Error * RecvFrame (CanFrame & frame, Timeout timeout) [protected], [virtual]`

Receive the next CAN frame.

Parameters

<i>frame</i>	A reference to the frame object that will be filled by the read.
<i>timeout</i>	The timeout (ms) to wait for the frame. A timeout of 0 will return immediately if no data is available. A timeout of < 0 will wait forever.

Returns

A pointer to an error object on failure, or NULL on success.

Reimplemented from [CanInterface](#).

5.70.2.5 const Error * SetBaud (int32 b) [virtual]

Set the CAN interface baud rate.

Parameters

<i>b</i>	The baud rate to set.
----------	-----------------------

Returns

A pointer to an error object on failure, or NULL on success.

Reimplemented from [CanInterface](#).

5.70.2.6 const Error * XmitFrame (CanFrame & frame, Timeout timeout) [protected],[virtual]

Write a CAN frame to the CAN network.

Parameters

<i>frame</i>	A reference to the frame to write.
<i>timeout</i>	The time to wait for the frame to be successfully sent. If the timeout is 0, the frame is written to the output queue and the function returns without waiting for it to be sent. If the timeout is <0 then the function will delay forever.

Returns

A pointer to an error object on failure, or NULL on success.

Reimplemented from [CanInterface](#).

5.70.3 Member Data Documentation**5.70.3.1 uint8 channel [protected]**

Which CAN channel to use (on multi-channel boards).

For the moment this is always set to zero.

The documentation for this class was generated from the following files:

- [can_ixxat_v3.h](#)
- [can_ixxat_v3.cpp](#)

5.71 KvaserCAN Class Reference

Kvaser specific CAN interface.

Inheritance diagram for KvaserCAN:

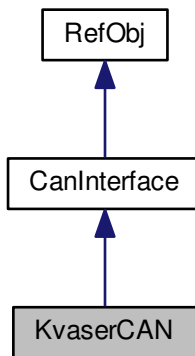

Collaboration diagram for KvaserCAN:

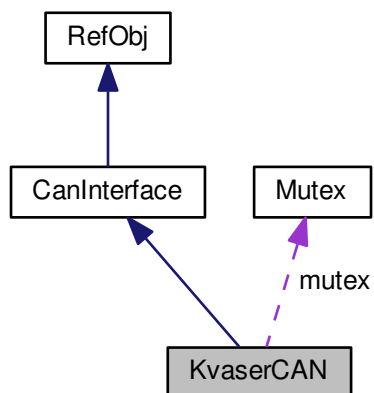

Public Member Functions

- [KvaserCAN](#) (void)
Construct a default CAN object.

- [KvaserCAN](#) (const char *port)
Construct a CAN object with a specified port name.
- virtual [~KvaserCAN](#) (void)
Destructor.
- const [Error](#) * [Open](#) (void)
Open the Kvaser CAN port.
- const [Error](#) * [Close](#) (void)
Close the CAN interface.
- const [Error](#) * [SetBaud](#) (int32 baud)
Set the CAN interface baud rate.

Protected Member Functions

- const [Error](#) * [RecvFrame](#) ([CanFrame](#) &frame, Timeout timeout)
Receive the next CAN frame.
- const [Error](#) * [XmitFrame](#) ([CanFrame](#) &frame, Timeout timeout)
Write a CAN frame to the CAN network.
- const [Error](#) * [ConvertError](#) (int err)
Convert error codes defined by the Vector CAN library into the standard error codes used by the motion library.

Protected Attributes

- int [open](#)
tracks the state of the interface as open or closed.
- int32 [baud](#)
Holds a copy of the last baud rate set.
- int [kvBaud](#)
Holds a value the Kvaser driver uses to identify bit rate.
- int [Handle_Rd](#)
File handle used to configure and read from the CAN channel.
- int [Handle_Wr](#)
File handle used to write to the CAN channel.

Additional Inherited Members

5.71.1 Detailed Description

Kvaser specific CAN interface.

This class extends the generic [CanInterface](#) class into a working interface for the Kvaser can device driver.

5.71.2 Constructor & Destructor Documentation

5.71.2.1 KvaserCAN (void)

Construct a default CAN object.

The CAN interface is closed initially, and no port name is selected.

5.71.2.2 KvaserCAN (const char * port)

Construct a CAN object with a specified port name.

The port name should be of the form CANx or KVASERx where x is the port number. The port numbers start at 0, so the first port would be identified by the port name CAN0.

Parameters

<i>port</i>	The port name string identifying the CAN device.
-------------	--

5.71.2.3 ~KvaserCAN (void) [virtual]

Destructor.

This closes the CAN port and frees the .dll

5.71.3 Member Function Documentation

5.71.3.1 const Error * Close (void) [virtual]

Close the CAN interface.

Returns

A pointer to an error object on failure, NULL on success.

Reimplemented from [CanInterface](#).

5.71.3.2 const Error * ConvertError (int err) [protected]

Convert error codes defined by the Vector CAN library into the standard error codes used by the motion library.

Parameters

<i>err</i>	The Vector style status code
------------	------------------------------

Returns

A pointer to an error object on failure, NULL on success.

5.71.3.3 const Error * Open (void) [virtual]

Open the Kvaser CAN port.

Before Open is called, the desired baud rate must have been specified by calling SetBaud, and the port name must have been set. If the baud was not specified, it will default to 1,000,000 BPS. If the port name is not set, it will default to CAN0.

Returns

A pointer to an error object on failure, NULL on success.

Reimplemented from [CanInterface](#).

5.71.3.4 `const Error * RecvFrame (CanFrame & frame, Timeout timeout)` [protected],[virtual]

Receive the next CAN frame.

Parameters

<i>frame</i>	A reference to the frame object that will be filled by the read.
<i>timeout</i>	The timeout (ms) to wait for the frame. A timeout of 0 will return immediately if no data is available. A timeout of < 0 will wait forever.

Returns

A pointer to an error object on failure, NULL on success.

Reimplemented from [CanInterface](#).

5.71.3.5 `const Error * SetBaud (int32 b) [virtual]`

Set the CAN interface baud rate.

Parameters

<i>b</i>	The baud rate to set.
----------	-----------------------

Returns

A pointer to an error object on failure, NULL on success.

Reimplemented from [CanInterface](#).

5.71.3.6 `const Error * XmitFrame (CanFrame & frame, Timeout timeout) [protected],[virtual]`

Write a CAN frame to the CAN network.

Parameters

<i>frame</i>	A reference to the frame to write.
<i>timeout</i>	The time to wait for the frame to be successfully sent. If the timeout is 0, the frame is written to the output queue and the function returns without waiting for it to be sent. If the timeout is <0 then the function will delay forever.

Returns

A pointer to an error object on failure, NULL on success.

Reimplemented from [CanInterface](#).

The documentation for this class was generated from the following files:

- [can_kvaser.h](#)
- [can_kvaser.cpp](#)

5.72 Linkage Class Reference

[Linkage](#) object, used for controlling a group of coordinated amplifiers.

Inheritance diagram for Linkage:

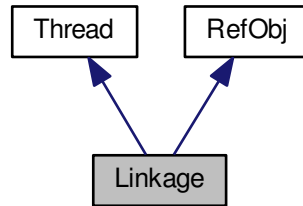

Collaboration diagram for Linkage:

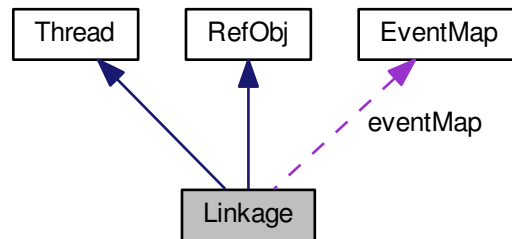

Public Member Functions

- [Linkage](#) ()
Default constructor.
- virtual [~Linkage](#) ()
Linkage object destructor.
- const [Error](#) * [Init](#) (uint16 ct, [Amp](#) a[])
Initialize a new linkage object.
- const [Error](#) * [Init](#) (uint16 ct, [Amp](#) *a[])
Initialize a new linkage object.
- const [Error](#) * [Configure](#) ([LinkSettings](#) &settings)
Configure a linkage.
- [Amp](#) & [GetAmp](#) (uint16 i)
Get a reference to the amplifier object at the specified location in the linkage.
- uint32 [GetAmpRef](#) (uint16 i)
Return a CML reference number for the amp object at the specified location in the linkage.

- const [Error](#) * [MoveTo](#) ([PointN](#) &p, [uunit](#) vel, [uunit](#) acc, [uunit](#) dec, [uunit](#) jrk, bool [start](#)=true)
Move to a point in space.
- const [Error](#) * [SetMoveLimits](#) ([uunit](#) vel, [uunit](#) acc, [uunit](#) dec, [uunit](#) jrk)
Set limits used for multi-axis point-to-point moves.
- const [Error](#) * [GetMoveLimits](#) ([uunit](#) &vel, [uunit](#) &acc, [uunit](#) &dec, [uunit](#) &jrk)
Return the move limits currently set for this linkage.
- const [Error](#) * [MoveTo](#) ([PointN](#) &p, bool [start](#)=true)
Move to a specified position.
- const [Error](#) * [StartMove](#) (void)
Start the moves that have already been programmed into all axes of this linkage.
- const [Error](#) * [WaitMoveDone](#) (Timeout timeout=-1)
Wait for the currently running move to finish, or for an error to occur.
- const [Error](#) * [WaitEvent](#) ([Event](#) &e, Timeout timeout, [LINK_EVENT](#) &match)
Wait for a linkage event condition.
- const [Error](#) * [WaitEvent](#) ([Event](#) &e, Timeout timeout=-1)
Wait for a linkage event condition.
- const [Error](#) * [HaltMove](#) (void)
Halt the current move.
- const [Error](#) * [SendTrajectory](#) ([LinkTrajectory](#) &trj, bool [start](#)=true)
Upload a multi-axis PVT move trajectory to the linkage and optionally start the move.
- const [Error](#) * [GetLatchedError](#) (int &)
Return any latched error codes held by the linkage object.
- void [ClearLatchedError](#) (void)
Clear any latched errors.
- [Amp](#) & [operator\[\]](#) ([uint16](#) i)
Return a reference to the specified amplifier object in this linkage.
- [uint16](#) [GetAmpCount](#) (void)
Return the number of amplifiers associated with this linkage.
- virtual [uint16](#) [GetAxesCount](#) (void)
Return the number of independent axes associated with this linkage.
- const [Error](#) * [GetPositionCommand](#) ([PointN](#) &p)
Get the current commanded position of the linkage.
- virtual const [Error](#) * [ConvertAmpToAxisPos](#) ([uunit](#) pos[])
Convert the linkage position from the amplifier frame to the axis frame.
- virtual const [Error](#) * [ConvertAxisToAmpPos](#) ([uunit](#) pos[])
Convert the linkage position from the axis frame to the amplifier frame.
- virtual const [Error](#) * [ConvertAmpToAxis](#) ([uunit](#) pos[], [uunit](#) vel[])
Convert position & velocity information from the amplifier frame to the axis frame.
- virtual const [Error](#) * [ConvertAxisToAmp](#) ([uunit](#) pos[], [uunit](#) vel[])
Convert position & velocity information from the axis frame to the amplifier frame.
- [uint32](#) [GetNetworkRef](#) (void)
Return a CML reference number for the [Network](#) this linkage is associated with.
- [NetworkType](#) [GetNetworkType](#) (void)
Return the network type for the network this linkage is associated with.

Public Attributes

- [EventMap eventMap](#)

This is an event map that is used to track linkage events and state changes.

Friends

- class **Amp**

Additional Inherited Members

5.72.1 Detailed Description

[Linkage](#) object, used for controlling a group of coordinated amplifiers.

5.72.2 Constructor & Destructor Documentation

5.72.2.1 [Linkage](#) (void)

Default constructor.

[Linkage::Init](#) must be called before this linkage object may be used.

5.72.3 Member Function Documentation

5.72.3.1 void [ClearLatchedError](#) (void) `[inline]`

Clear any latched errors.

This function clears the latched error information returned by [Linkage::GetLatchedError\(\)](#). Latched errors are automatically cleared at the start of a new move. This call may be used to clear latched error information at any other time.

5.72.3.2 const Error * [Configure](#) ([LinkSettings](#) & *settings*)

Configure a linkage.

The linkage object will be configured to use the various settings passed in the [LinkSettings](#) object.

When a new [Linkage](#) object is created, it will be configured using a default set of settings. These settings can be modified through this call. Set the documentation of the [LinkSettings](#) object for details of the available settings and their default values.

Parameters

<i>settings</i>	The new settings to be used. A local copy of this object will be made by the linkage.
-----------------	---

Returns

An error object pointer, or NULL on success.

5.72.3.3 `virtual const Error* ConvertAmpToAxis (uunit pos[], uunit vel[]) [inline],[virtual]`

Convert position & velocity information from the amplifier frame to the axis frame.

The passed arrays contain a position and velocity for each amplifier on entry. These values should be converted to axis positions & velocities in this function.

By default, this function doesn't do anything, however it is a virtual function to allow it to be extended in sub-classes.

Parameters

<i>pos</i>	An array of amplifier positions on entry, and axes positions on exit.
<i>vel</i>	An array of amplifier velocities on entry, and axis velocities on exit.

Returns

NULL on success or an [Error](#) pointer on failure.

5.72.3.4 `virtual const Error* ConvertAmpToAxisPos (uunit pos[]) [inline],[virtual]`

Convert the linkage position from the amplifier frame to the axis frame.

The passed array contains a position for each amplifier on entry. These positions should be converted to axis positions in this function. By default, this function doesn't do anything, however it is a virtual function to allow it to be extended in sub-classes.

Parameters

<i>pos</i>	An array of amplifier positions on entry, and axes positions on exit.
------------	---

Returns

NULL on success or an [Error](#) pointer on failure.

5.72.3.5 `virtual const Error* ConvertAxisToAmp (uunit pos[], uunit vel[]) [inline],[virtual]`

Convert position & velocity information from the axis frame to the amplifier frame.

The passed arrays contain a position and velocity for each axis on entry. These values should be converted to amp positions & velocities in this function.

By default, this function doesn't do anything, however it is a virtual function to allow it to be extended in sub-classes.

Parameters

<i>pos</i>	An array of axis positions on entry, and amplifier positions on exit.
<i>vel</i>	An array of axis velocities on entry, and amplifier velocities on exit.

Returns

NULL on success or an [Error](#) pointer on failure.

5.72.3.6 `virtual const Error* ConvertAxisToAmpPos (uunit pos[]) [inline],[virtual]`

Convert the linkage position from the axis frame to the amplifier frame.

The passed array contains a position for each axis on entry. These positions should be converted to amplifier positions in this function. By default, this function doesn't do anything, however it is a virtual function to allow it to be extended in sub-classes.

Parameters

<i>pos</i>	An array of axis positions on entry, and amp positions on exit.
------------	---

Returns

NULL on success or an [Error](#) pointer on failure.

5.72.3.7 `Amp & GetAmp (uint16 i)`

Get a reference to the amplifier object at the specified location in the linkage.

Note that if `CML_DEBUG_ASSERT` is defined, then the standard C assert function will be used to check for an invalid index.

NOTE: This function is unsafe and has been deprecated. Use [Linkage::GetAmpRef\(\)](#) as a safer alternative.

Parameters

<i>i</i>	The index of the amplifier to access.
----------	---------------------------------------

Returns

A reference to the amplifier object.

5.72.3.8 `uint16 GetAmpCount (void) [inline]`

Return the number of amplifiers associated with this linkage.

Returns

The amplifier count.

5.72.3.9 `uint32 GetAmpRef (uint16 i)`

Return a CML reference number for the amp object at the specified location in the linkage.

[RefObj::LockRef\(\)](#) can then be used to safely obtain a pointer to the actual [Amp](#) object.

Parameters

<i>i</i>	The index of the amplifier to access.
----------	---------------------------------------

Returns

A reference to the amplifier object.

5.72.3.10 `virtual uint16 GetAxesCount (void) [inline],[virtual]`

Return the number of independent axes associated with this linkage.

For a standard [Linkage](#) object, this will be the same as the amp count, however, this function is virtual to allow more complex structures to be represented in sub-classes.

Returns

The number of independent axes for this [Linkage](#).

5.72.3.11 const Error* GetLatchedError (int & amp) [inline]

Return any latched error codes held by the linkage object.

When an error occurs during a move, the linkage latches the first error to occur and the index of the amplifier that caused it.

Note that the latched error information will be reset automatically at the start of any new move.

Parameters

<i>amp</i>	The index of the amplifier producing the latched error will be returned. -1 will be returned if the amplifier is unknown.
------------	---

Returns

A pointer to the latched error object, or NULL if no error was latched.

5.72.3.12 const Error * GetMoveLimits (uunit & vel, uunit & acc, uunit & dec, uunit & jrk)

Return the move limits currently set for this linkage.

Parameters

<i>vel</i>	Returns maximum velocity
<i>acc</i>	Returns maximum acceleration
<i>dec</i>	Returns maximum deceleration
<i>jrk</i>	Returns maximum jerk

Returns

An error object pointer, or NULL on success.

5.72.3.13 const Error * GetPositionCommand (PointN & p)

Get the current commanded position of the linkage.

Note that this function queries the position of each amplifier sequentially and therefore the returned position information will only be accurate if the linkage is at rest when the function is called.

Parameters

<i>p</i>	A point that will be filled in with the current Linkage commanded position.
----------	---

Returns

An error object pointer, or NULL on success.

5.72.3.14 `const Error * HaltMove (void)`

Halt the current move.

The exact type of halt can be programmed individually for each axis using the [Amp::SetHaltMode](#) function.

Returns

An error object pointer, or NULL on success.

5.72.3.15 `const Error * Init (uint16 ct, Amp a[])`

Initialize a new linkage object.

If the object has already been initialized, this will fail with an error.

All amplifiers attached to a linkage must be initialized, and must share the same network object. Also, amplifiers may only be attached to one linkage at a time, so this function will fail if any of the passed amplifier objects is already attached to a [Linkage](#).

The linkage object will maintain pointers to each of the amplifier objects passed to this function. The amplifiers may not be destroyed until after the linkage object is.

Parameters

<i>ct</i>	The number of amplifiers to be used with this linkage. Note that this must be between 1 and CML_MAX_AMPS_PER_LINK.
<i>a</i>	An array of amplifiers to be assigned to this linkage. There must be at least <i>ct</i> amplifiers in this array.

Returns

An error object pointer, or NULL on success.

5.72.3.16 `const Error * Init (uint16 ct, Amp * a[])`

Initialize a new linkage object.

If the object has already been initialized, this will fail with an error.

All amplifiers attached to a linkage must be initialized, and must share the same network object. Also, amplifiers may only be attached to one linkage at a time, so this function will fail if any of the passed amplifier objects is already attached to a [Linkage](#).

The linkage object will maintain pointers to each of the amplifier objects passed to this function. The amplifiers may not be destroyed until after the linkage object is.

Parameters

<i>ct</i>	The number of amplifiers to be used with this linkage. Note that this must be between 1 and CML_MAX_AMPS_PER_LINK.
<i>a</i>	An array of pointer to amplifier objects to be assigned to this linkage. There must be at least <i>ct</i> pointers in this array.

Returns

An error object pointer, or NULL on success.

5.72.3.17 `const Error * MoveTo (PointN & p, uunit vel, uunit acc, uunit dec, uunit jrk, bool start = true)`

Move to a point in space.

The number of dimensions of the point must equal the number of axes controlled by the [Linkage](#) (as returned by [Linkage::GetAxesCount](#)).

This method causes the linkage to perform a straight line move in N space from the present position to the specified point. The move will be limited in velocity, acceleration & jerk to the passed values.

The linkage is assumed to be at rest when this method is called. If this isn't the case, then an error will result.

Note that this function causes a trajectory to be calculated and passed to the amplifiers as a series of PVT points. This calculation requires floating point math, so this function is not available if floating point support has not been enabled in [CML_Settings.h](#).

Parameters

<i>p</i>	The point in N space to move to.
<i>vel</i>	Maximum velocity
<i>acc</i>	Maximum acceleration
<i>dec</i>	Maximum deceleration
<i>jrk</i>	Maximum jerk
<i>start</i>	If true (the default), the profile will be started by this call. If false, the profile will be uploaded, but not started. In that case the move may be later started by a call to Linkage::StartMove .

Returns

An error object pointer, or NULL on success.

5.72.3.18 `const Error * MoveTo (PointN & p, bool start = true)`

Move to a specified position.

This move uses the limits previously set using [Linkage::SetMoveLimits](#).

Parameters

<i>p</i>	The point to move to.
<i>start</i>	If true (the default), the profile will be started by this call. If false, the profile will be uploaded, but not started. In that case the move may be later started by a call to Linkage::StartMove .

Returns

An error object pointer, or NULL on success.

5.72.3.19 `Amp& operator[] (uint16 i) [inline]`

Return a reference to the specified amplifier object in this linkage.

This is the same as [Linkage::GetAmp](#)

NOTE: This function is unsafe and has been deprecated. Use [Linkage::GetAmpRef\(\)](#) as a safer alternative.

Parameters

<i>i</i>	The amplifier index location
----------	------------------------------

Returns

A reference to the amp object

5.72.3.20 `const Error * SendTrajectory (LinkTrajectory & trj, bool start = true)`

Upload a multi-axis PVT move trajectory to the linkage and optionally start the move.

Parameters

<i>trj</i>	Reference to the linkage trajectory to be used. A local reference to this trajectory will be stored if the entire profile will not fit in the amplifiers on-board buffer. This pointer will be kept until the entire profile has been uploaded to the linkage. It is therefore important to ensure that the trajectory object passed here will remain valid (i.e. not be deallocated) until the linkage has called the LinkTrajectory.Finish() method.
<i>start</i>	If true (the default), the profile will be started by this call. If false, the profile will be uploaded, but not started. In that case the move may be later started by a call to Linkage::StartMove .

Returns

An error object.

5.72.3.21 `const Error * SetMoveLimits (uunit vel, uunit acc, uunit dec, uunit jrk)`

Set limits used for multi-axis point-to-point moves.

Parameters

<i>vel</i>	Maximum velocity
<i>acc</i>	Maximum acceleration
<i>dec</i>	Maximum deceleration
<i>jrk</i>	Maximum jerk

Returns

An error object pointer, or NULL on success.

5.72.3.22 `const Error * StartMove (void)`

Start the moves that have already been programmed into all axes of this linkage.

Returns

An error object pointer, or NULL on success.

5.72.3.23 `const Error * WaitEvent (Event & e, Timeout timeout, LINK_EVENT & match)`

Wait for a linkage event condition.

This function can be used to wait on any generic event associated with the linkage.

Parameters

<i>e</i>	The event to wait on.
<i>timeout</i>	The timeout for the wait (milliseconds). If < 0, then wait forever.
<i>match</i>	Returns the matching event condition.

Returns

A pointer to an error object, or NULL on success.

5.72.3.24 `const Error * WaitEvent (Event & e, Timeout timeout = -1)`

Wait for a linkage event condition.

This function can be used to wait on any generic event associated with the linkage.

Parameters

<i>e</i>	The event to wait on.
<i>timeout</i>	The timeout for the wait (milliseconds). If < 0, then wait forever (default).

Returns

A pointer to an error object, or NULL on success.

5.72.3.25 `const Error * WaitMoveDone (Timeout timeout = -1)`

Wait for the currently running move to finish, or for an error to occur.

Parameters

<i>timeout</i>	The maximum time to wait (milliseconds). Default is -1 (forever).
----------------	---

Returns

A pointer to an error object, or NULL on success.

The documentation for this class was generated from the following files:

- [CML_Linkage.h](#)
- [Linkage.cpp](#)

5.73 LinkError Class Reference

This class represents error conditions that can occur in the [Linkage](#) class.

Inheritance diagram for LinkError:

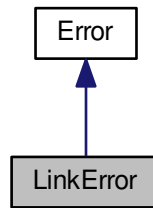

Collaboration diagram for LinkError:

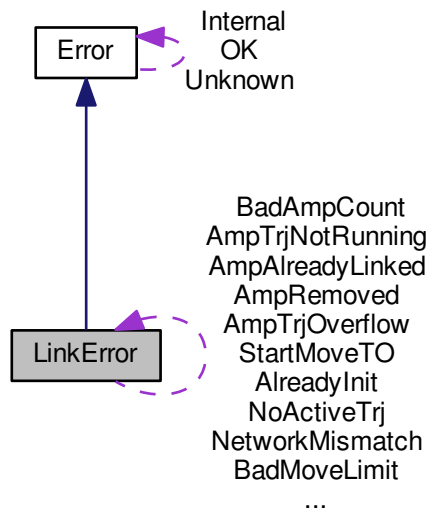

Static Public Attributes

- static const [LinkError NetworkMismatch](#)
The amplifier objects used to init the linkage are not all attached to the same [CanOpen](#) network.
- static const [LinkError BadAmpCount](#)
An illegal number of amplifiers was passed to [Linkage::Init](#).
- static const [LinkError AlreadyInit](#)
Init was called on a [Linkage](#) that is already initialized.

- static const [LinkError AmpAlreadyLinked](#)
The passed amplifier object is already assigned to a linkage.
- static const [LinkError AxisCount](#)
The point dimension doesn't match the number of linkage axes.
- static const [LinkError AmpTrjOverflow](#)
Amplifier trajectory structure overflow.
- static const [LinkError AmpTrjInUse](#)
Amplifier trajectory already in use.
- static const [LinkError AmpTrjNotRunning](#)
Amplifier trajectory not presently in use.
- static const [LinkError NoActiveTrj](#)
No linkage trajectory is active.
- static const [LinkError BadMoveLimit](#)
A zero or negative move limit was detected.
- static const [LinkError UnknownAmpErr](#)
Unknown amplifier error.
- static const [LinkError StartMoveTO](#)
Timeout waiting on amplifier to respond to start move command.
- static const [LinkError NotSupported](#)
Returned if `Linkage::MoveTo` is called on a system where floating point math was not enabled at compile time.
- static const [LinkError AmpRemoved](#)
An amp object referenced by the linkage is no longer valid.

Protected Member Functions

- [LinkError](#) (uint16 id, const char *desc)
Standard protected constructor.

Additional Inherited Members

5.73.1 Detailed Description

This class represents error conditions that can occur in the [Linkage](#) class.

5.73.2 Member Data Documentation

5.73.2.1 const [LinkError NetworkMismatch](#) [static]

The amplifier objects used to init the linkage are not all attached to the same [CanOpen](#) network.

5.73.2.2 const [LinkError NotSupported](#) [static]

Returned if [Linkage::MoveTo](#) is called on a system where floating point math was not enabled at compile time.

The documentation for this class was generated from the following file:

- [CML_Linkage.h](#)

5.74 LinkSettings Class Reference

[Linkage](#) object settings.

Public Member Functions

- [LinkSettings](#) ()
Default constructor.

Public Attributes

- Timeout [moveAckTimeout](#)
This setting gives the amount of time (milliseconds) to wait for all amplifiers to acknowledge the start of a new move before reporting an error.
- bool [haltOnPosWarn](#)
If this setting is set to true, then the linkage object will automatically issue a halt to all axes if any of them reports a position warning window condition during a move.
- bool [haltOnVelWin](#)
If this setting is set to true, then the linkage object will automatically issue a halt to all axes if any of them reports a velocity tracking window condition during a move.

5.74.1 Detailed Description

[Linkage](#) object settings.

An object of this type may be passed to the [Linkage::Configure](#) function to define the settings used by that linkage.

5.74.2 Constructor & Destructor Documentation

5.74.2.1 [LinkSettings](#) ()

Default constructor.

All settings are set to their default values at construction time.

5.74.3 Member Data Documentation

5.74.3.1 bool [haltOnPosWarn](#)

If this setting is set to true, then the linkage object will automatically issue a halt to all axes if any of them reports a position warning window condition during a move.

Default: false

5.74.3.2 bool [haltOnVelWin](#)

If this setting is set to true, then the linkage object will automatically issue a halt to all axes if any of them reports a velocity tracking window condition during a move.

Default: false

5.74.3.3 Timeout moveAckTimeout

This setting gives the amount of time (milliseconds) to wait for all amplifiers to acknowledge the start of a new move before reporting an error.

When a new move is started on the linkage, each amplifier will respond with an acknowledgment. If all of these responses are not received in this amount of time then an error will be reported.

Default: 200 ms

The documentation for this class was generated from the following files:

- [CML_Linkage.h](#)
- [Linkage.cpp](#)

5.75 LinkTrajectory Class Reference

[Linkage](#) trajectory.

Inheritance diagram for LinkTrajectory:

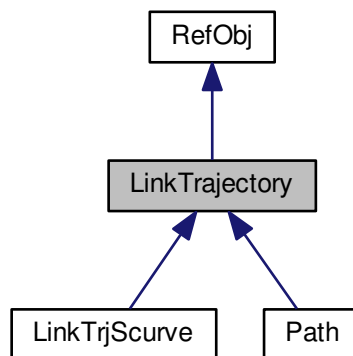

Collaboration diagram for LinkTrajectory:

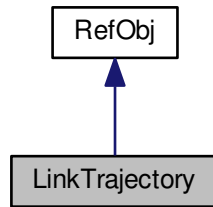

Public Member Functions

- [LinkTrajectory](#) (void)
LinkTrajectory default constructor.
- virtual [~LinkTrajectory](#) ()
Virtual destructor.
- virtual const [Error](#) * [StartNew](#) (void)
Start a new trajectory.
- virtual void [Finish](#) (void)
Trajectory finished.
- virtual int [GetDim](#) (void)=0
Get the dimension of the trajectory.
- virtual bool [UseVelocityInfo](#) (void)
This function indicates whether the velocity information returned by NextSegment should be used.
- virtual int [MaximumBufferPointsToUse](#) (void)
This function allows a trajectory object to effectively reduce the size of the amplifier's internal trajectory buffer.
- virtual const [Error](#) * [NextSegment](#) (uunit pos[], uunit vel[], uint8 &time)=0
Get the next segment of position, velocity & time info.

Additional Inherited Members

5.75.1 Detailed Description

[Linkage](#) trajectory.

This class is similar to the [Trajectory](#) class, except that it is used to pass multi-axis trajectory information to a linkage rather than single axis trajectory information to a single amplifier.

Like the base [Trajectory](#) class, the base [LinkTrajectory](#) class is pure virtual. This class should be extended by actual trajectory implementations.

5.75.2 Member Function Documentation

5.75.2.1 `virtual void Finish (void) [inline], [virtual]`

Trajectory finished.

This function is called by the [Linkage](#) object when it is finished with the trajectory and no longer holding a reference to it. Typically, this will happen after the [LinkTrajectory::NextSegment](#) function has returned a zero time value, although it can also occur when some external event causes the trajectory to be aborted.

Once the [Linkage](#) object calls [LinkTrajectory::Finish](#) it will clear it's reference to the trajectory object. No further access to the trajectory object will be made after Finish is called.

Reimplemented in [LinkTrjScurve](#).

5.75.2.2 `virtual int GetDim (void) [pure virtual]`

Get the dimension of the trajectory.

The trajectory dimension gives the number of axes defined for the trajectory. This can not change from the time [Start-New\(\)](#) is called to the time [Finish\(\)](#) is called. The position and velocity arrays passed to [NextSegment](#) will be of at least this size.

Returns

The dimension of the trajectory.

Implemented in [Path](#), and [LinkTrjScurve](#).

5.75.2.3 `virtual int MaximumBufferPointsToUse (void) [inline], [virtual]`

This function allows a trajectory object to effectively reduce the size of the amplifier's internal trajectory buffer.

Normally it's desirable to download as many points as possible to the amplifier at once. For some applicaitons however, the trajectory information is calculated in real time and the amplifier's buffer causes unacceptable latency. For such applications this function may be used to reduce the delay between calculating trajectory points and the amplifier's acting on them.

Note that the amplifier requires some buffering of points in order to interpolate between them. This function should never return a value less then 2 or a trajectory underflow will certainly occur.

Returns

The maximum number of trajectory points that should be stored in the amplifier at any time. By default this returns a very large number which ensures that the amplifier's full buffer will be used.

5.75.2.4 `virtual const Error* NextSegment (uunit pos[], uunit vel[], uint8 & time) [pure virtual]`

Get the next segment of position, velocity & time info.

Note that this function will be called from the high priority CANopen receiver task. Therefore, no lengthy processing should be done here.

Parameters

<i>pos</i>	An array where the position values will be returned. This array will be at least D elements long, where D is the trajectory dimension as returned by LinkTrajectory::GetDim()
<i>vel</i>	An array where the velocity values will be returned. These values are ignored if the function UseVelocityInfo() returns false.
<i>time</i>	The segment time is returned here. This is in milliseconds and ranges from 1 to 255. If zero is returned, this is the last frame in the profile.

Returns

A pointer to an error object on failure, or NULL on success.

Implemented in [Path](#), and [LinkTrjScurve](#).

5.75.2.5 `virtual const Error* StartNew (void) [inline],[virtual]`

Start a new trajectory.

This function is called before the first call to [LinkTrajectory::NextSegment](#). It gives the trajectory object a chance to return an error indicating that it isn't ready to be sent.

Returns

An error pointer if the trajectory object is not available, or NULL if it is ready to be sent.

Reimplemented in [Path](#), and [LinkTrjScurve](#).

5.75.2.6 `virtual bool UseVelocityInfo (void) [inline],[virtual]`

This function indicates whether the velocity information returned by [NextSegment](#) should be used.

If this returns true, then the amplifier will operate in PVT mode and use cubic polynomial interpolation between trajectory segments. If this returns false, then the velocity returned by [NextSegment](#) will be ignored, and the amplifier will run in PT mode using linear interpolation between sets of points.

Returns

true if velocity information should be used (default), or false if velocities should be ignored.

The documentation for this class was generated from the following file:

- [CML_Trajectory.h](#)

5.76 LinkTrjScurve Class Reference

Multi-axis s-curve profile.

Inheritance diagram for LinkTrjScurve:

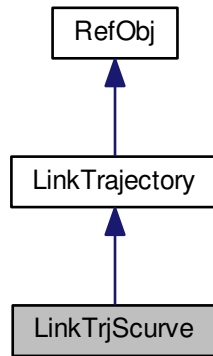

Collaboration diagram for LinkTrjScurve:

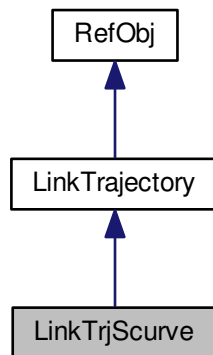

Public Member Functions

- [LinkTrjScurve](#) ()
Default constructor for multi-axis s-curve trajectory.
- const [Error](#) * [Calculate](#) ([PointN](#) &start, [PointN](#) &end, [uunit](#) vel, [uunit](#) acc, [uunit](#) dec, [uunit](#) jrk)
Calculate a multi-axis s-curve trajectory.
- int [GetDim](#) (void)
Get the dimension of the trajectory.
- const [Error](#) * [StartNew](#) (void)

Start a new move using this trajectory.

- void [Finish](#) (void)

Finish this trajectory.

- const [Error](#) * [NextSegment](#) (uunit pos[], uunit vel[], uint8 &time)

Retrieve the next segment of this trajectory.

Additional Inherited Members

5.76.1 Detailed Description

Multi-axis s-curve profile.

This extends the single axis [TrjScurve](#) object for use in multi-axis linkage moves.

5.76.2 Member Function Documentation

5.76.2.1 const [Error](#) * [Calculate](#) ([PointN](#) & s, [PointN](#) & e, uunit vel, uunit acc, uunit dec, uunit jrk)

Calculate a multi-axis s-curve trajectory.

This function calculates the straight line move between the two passed positions.

Parameters

<i>s</i>	The starting position
<i>e</i>	The ending position
<i>vel</i>	The max velocity
<i>acc</i>	The max acceleration
<i>dec</i>	The max deceleration
<i>jrk</i>	The max jerk (rate of change of velocity)

Returns

A pointer to an error object, or NULL on success.

5.76.2.2 int [GetDim](#) (void) [[inline](#)],[[virtual](#)]

Get the dimension of the trajectory.

The trajectory dimension gives the number of axes defined for the trajectory. This can not change from the time [StartNew\(\)](#) is called to the time [Finish\(\)](#) is called. The position and velocity arrays passed to [NextSegment](#) will be of at least this size.

Returns

The dimension of the trajectory.

Implements [LinkTrajectory](#).

5.76.2.3 const [Error](#) * [NextSegment](#) (uunit pos[], uunit vel[], uint8 & time) [[virtual](#)]

Retrieve the next segment of this trajectory.

The positions & velocities for all axes are returned in the passed arrays.

Parameters

<i>pos</i>	An array which will be filled with position information.
<i>vel</i>	An array which will be filled with velocity information.
<i>time</i>	A reference to a variable where the time (milliseconds) will be returned.

Returns

A pointer to an error object, or NULL on success.

Implements [LinkTrajectory](#).

5.76.2.4 `const Error * StartNew (void) [virtual]`

Start a new move using this trajectory.

The trajectory must have already been calculated when this function is called.

Returns

A pointer to an error object, or NULL on success.

Reimplemented from [LinkTrajectory](#).

The documentation for this class was generated from the following files:

- [CML_TrjScurve.h](#)
- [TrjScurve.cpp](#)

5.77 LinuxEcatHardware Class Reference

This class provides an interface to the Ethernet ports on a linux system.

Inheritance diagram for LinuxEcatHardware:

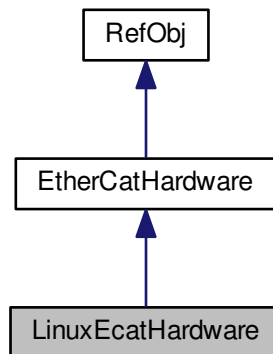

Collaboration diagram for LinuxEcatHardware:

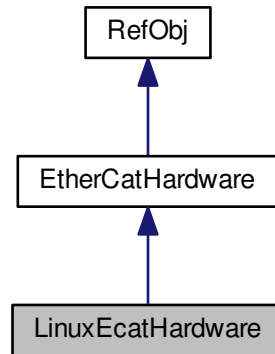

Additional Inherited Members

5.77.1 Detailed Description

This class provides an interface to the Ethernet ports on a linux system.

It can be used to send and received formatted [EtherCAT](#) packets.

The documentation for this class was generated from the following files:

- ecat_linux.h
- ecat_linux.cpp

5.78 LSS Class Reference

CANopen Layer Setting Services object.

Inheritance diagram for LSS:

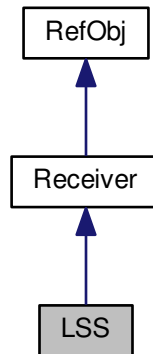

Collaboration diagram for LSS:

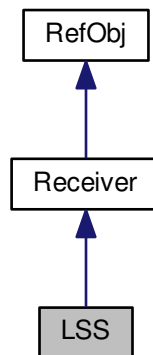

Public Member Functions

- [LSS](#) ([CanOpen](#) &co)
Default constructor for the [LSS](#) object.
- int [FindAmplifiers](#) (int max, [uint32](#) serial[])
Search the CANopen network for Copley amplifiers.
- void [setTimeout](#) (Timeout to)
Set the timeout value used by the [LSS](#) protocol.
- Timeout [getTimeout](#) (void)

Get the current timeout value used by the [LSS](#) protocol.

- const [Error](#) * [GetAmpNodeID](#) (uint32 serial, byte &nodeID)

Get the current CANopen node ID of the specified amplifier.

- const [Error](#) * [SetAmpNodeID](#) (uint32 serial, byte nodeID)

Set the CANopen node ID of the specified amplifier.

Protected Member Functions

- const [Error](#) * [SelectAmp](#) (uint32 serial)

Put the specified amplifier into [LSS](#) configure mode.

- uint32 [FindAmpSerial](#) (uint32 low, uint32 high)

Find the serial number of the first amplifier in the passed range.

- int [NewFrame](#) ([CanFrame](#) &frame)

This method is called by the main CAN network listener when a new [LSS](#) response frame is received.

- const [Error](#) * [Xmit](#) (byte cs, uint32 data=0)

Transmit a [LSS](#) CAN frame.

Additional Inherited Members

5.78.1 Detailed Description

CANopen Layer Setting Services object.

The Layer Setting Services ([LSS](#)) protocol is part of the CANopen network standard. The intent of [LSS](#) is to allow low level network settings, such as the network bit rate and device node ID numbers to be configured over the network.

The CANopen protocol requires each device on the network to have a unique node ID number in the range 1 to 127. In general, it's not possible to communicate with a device using CANopen if it doesn't have a unique node ID in this range.

The [LSS](#) protocol allows some limited communication with any device on the network even if it doesn't have a node ID set. This allows node ID numbers to be assigned to devices over the network.

This object implements the [LSS](#) protocol and allows devices on the network to be queried and configured.

For more detailed information on the [LSS](#) protocol please see the CANopen standard document DSP305.

5.78.2 Constructor & Destructor Documentation

5.78.2.1 [LSS](#) ([CanOpen](#) & *co*)

Default constructor for the [LSS](#) object.

Parameters

<i>co</i>	A reference to the CANopen network object over which this protocol will run.
-----------	--

5.78.3 Member Function Documentation

5.78.3.1 int [FindAmplifiers](#) (int *max*, uint32 *serial[]*)

Search the CANopen network for Copley amplifiers.

This function uses the CANopen Layer Setting Services ([LSS](#)) protocol to find amplifiers on the network. All Copley amplifiers on the CANopen network can be identified using this protocol, even if they do not have a valid CANopen node ID number configured.

On return from this function, the passed array will have been filled with the serial numbers of all the amplifiers found. These serial numbers may then be passed to [LSS::SetAmpNodeID](#) to assign a node ID number to the amplifier.

Note that firmware support for the [LSS](#) protocol was added starting with version 4.04. Any amplifier on the network with earlier firmware will not be discovered using this technique.

Parameters

<i>max</i>	The maximum number of amplifier serial numbers to be returned.
<i>serial</i>	An array where the amplifier serial numbers will be returned. This array must be at least max elements long.

Returns

The number of amplifiers actually found. This is not limited to the max parameter value

5.78.3.2 uint32 FindAmpSerial (uint32 low, uint32 high) [protected]

Find the serial number of the first amplifier in the passed range.

Parameters

<i>low</i>	The lower limit of the range
<i>high</i>	The upper limit of the range

Returns

the serial number, or zero if no amp found.

5.78.3.3 const Error * GetAmpNodeID (uint32 serial, byte & nodeID)

Get the current CANopen node ID of the specified amplifier.

Parameters

<i>serial</i>	The serial number of the amplifier to query.
<i>nodeID</i>	The node ID will be returned here.

Returns

A pointer to an error object, or NULL on success.

5.78.3.4 Timeout getTimeout (void) [inline]

Get the current timeout value used by the [LSS](#) protocol.

Returns

The current timeout in milliseconds.

5.78.3.5 `int NewFrame (CanFrame & frame)` [protected],[virtual]

This method is called by the main CAN network listener when a new [LSS](#) response frame is received.

Parameters

<i>frame</i>	A reference to the CAN fame that was received
--------------	---

Returns

Non-zero if the frame was handled.

Reimplemented from [Receiver](#).

5.78.3.6 `const Error * SelectAmp (uint32 serial)` [protected]

Put the specified amplifier into [LSS](#) configure mode.

All other amplifiers on the network are switched into [LSS](#) operational mode.

Parameters

<i>serial</i>	The serial number of the device to configure
---------------	--

Returns

A pointer to an error object, or NULL on success.

5.78.3.7 `const Error * SetAmpNodeID (uint32 serial, byte nodeID)`

Set the CANopen node ID of the specified amplifier.

Parameters

<i>serial</i>	The serial number of the amplifier to update.
<i>nodeID</i>	The CANopen node ID to assign to this amplifier.

Returns

A pointer to an error object, or NULL on success.

5.78.3.8 `void setTimeout (Timeout to)` [inline]

Set the timeout value used by the [LSS](#) protocol.

Parameters

<i>to</i>	The new timeout (milliseconds)
-----------	--------------------------------

5.78.3.9 `const Error * Xmit (byte cs, uint32 data = 0)` [protected]

Transmit a [LSS](#) CAN frame.

Parameters

<code>cs</code>	The command specifier for this frame.
<code>data</code>	The data passed with the frame.

Returns

A pointer to an error object, or NULL on success.

The documentation for this class was generated from the following files:

- [CML_CanOpen.h](#)
- [LSS.cpp](#)

5.79 MtrInfo Struct Reference

Motor information structure.

Public Member Functions

- [MtrInfo](#) (void)
Motor info structure default constructor.

Public Attributes

- [uint16 type](#)
Motor type.
- char [mfgName](#) [COPLEY_MAX_STRING]
Name of the motor manufacturer.
- char [model](#) [COPLEY_MAX_STRING]
Motor model number.
- [int16 poles](#)
Number of pole pairs (i.e.
- [uint16 resistance](#)
Motor resistance (10 milliohm units)
- [uint16 inductance](#)
Motor inductance (10 microhenry units)
- [uint32 trqPeak](#)
Peak torque (0.01 Newton millimeters)
- [uint32 trqCont](#)
Continuous torque (0.01 Newton millimeters)
- [uint32 trqConst](#)
Torque constant (0.01 Newton millimeters / Amp)
- [uint velMax](#)
Max velocity.
- [uint32 backEMF](#)
Back EMF constant (10 millivolts / KRPM)

- [uint32 inertia](#)
Inertia.
- [bool tempSensor](#)
Motor has a temperature sensor (true/false)
- [bool mtrReverse](#)
Reverse motor wiring if true.
- [bool encReverse](#)
Reverse encoder direction if true.
- [int16 hallType](#)
Type of hall sensors on motor. See documentation for details.
- [int16 hallWiring](#)
Hall wiring code, see documentation for details.
- [int16 hallOffset](#)
Hall offset (degrees)
- [bool hasBrake](#)
Motor has a brake if true.
- [int16 stopTime](#)
Delay (milliseconds) between disabling amp & applying brake During this time the amp will attempt to actively stop motor.
- [int16 brakeDelay](#)
Delay (milliseconds) between applying brake & disabling PWM.
- [uunit brakeVel](#)
Velocity below which brake will be applied.
- [int16 encType](#)
Encoder type. See documentation for details.
- [int32 ctsPerRev](#)
Encoder counts / revolution (rotary motors only)
- [int16 encUnits](#)
Encoder units (linear motor only)
- [int16 encRes](#)
Encoder resolution (encoder units / count) - linear motors only.
- [int32 eleDist](#)
Motor electrical distance (encoder units / electrical phase) - linear only.
- [int16 mtrUnits](#)
Motor units (used by CME program)
- [int32 stepsPerRev](#)
Microsteps / motor rotation (used for Stepanet amplifiers)
- [int16 encShift](#)
Analog Encoder shift value (used only with Analog encoders)
- [int32 ndxDist](#)
Index mark distance (reserved for future use)
- [int16 loadEncType](#)
Load encoder type (0 for none).
- [int32 loadEncRes](#)
Load encoder resolution.
- [bool loadEncReverse](#)
Reverse load encoder if true.
- [int32 gearRatio](#)

Load encoder gear ratio.

- [uint16 resolverCycles](#)

Resolver cycles / rev.

- [int16 hallVelShift](#)

Hall velocity shift value.

- [uint32 mtrEncOptions](#)

Motor Encoder options.

- [uint32 loadEncOptions](#)

Load Encoder options.

5.79.1 Detailed Description

Motor information structure.

This structure holds information about the motor connected to the amplifier.

The amplifier uses the information in this structure when controlling the motor. It is very important that the information provided to the amplifier be as accurate as possible for proper motor control.

Use the methods [Amp::GetMtrInfo](#) and [Amp::SetMtrInfo](#) to upload / download the information contained in this structure.

Note that unlike many amplifier parameters, motor parameters are always stored in non-volatile flash memory.

5.79.2 Constructor & Destructor Documentation

5.79.2.1 MtrInfo (void)

Motor info structure default constructor.

This simply initializes all members to legal default values.

5.79.3 Member Data Documentation

5.79.3.1 int32 gearRatio

Load encoder gear ratio.

This parameter is used by the CME software and gives a ratio of motor encoder counts to load encoder counts.

5.79.3.2 int16 hallVelShift

Hall velocity shift value.

This parameter is only used on servo systems where there is no encoder and digital hall sensors are used for velocity feedback. In that case, this shift value can be used to scale up the calculated velocity.

5.79.3.3 uint32 loadEncOptions

Load Encoder options.

This bitmapped parameter is used to specify various configuration options for the load encoder. See documentation.

5.79.3.4 int32 loadEncRes

Load encoder resolution.

This is encoder counts/rev for rotary encoders, or nanometers/count for linear encoders.

5.79.3.5 int16 loadEncType

Load encoder type (0 for none).

See amplifier documentation for possible values.

5.79.3.6 uint32 mtrEncOptions

Motor Encoder options.

This bitmapped parameter is used to specify various configuration options for the motor encoder. See documentation.

5.79.3.7 int16 poles

Number of pole pairs (i.e.

number of electrical phases) per rotation. Used for rotary motors only.

5.79.3.8 uint16 resolverCycles

Resolver cycles / rev.

This parameter gives the number of resolver cycles / motor rev. It's only used on systems that use a resolver for position feedback. Default is 1 cycle/rev.

The documentation for this struct was generated from the following files:

- [CML_AmpStruct.h](#)
- [AmpStruct.cpp](#)

5.80 Mutex Class Reference

This class represents an object that can be used by multiple threads to gain safe access to a shared resource.

Public Member Functions

- [Mutex](#) (void)
Create a new mutex object.
- virtual [~Mutex](#) ()
Free any system resources associated with the mutex.
- const [Error](#) * [Lock](#) (void)
Lock the mutex.
- const [Error](#) * [Unlock](#) (void)
Unlock the mutex.

5.80.1 Detailed Description

This class represents an object that can be used by multiple threads to gain safe access to a shared resource.

If an attempt is made to lock a mutex that is currently locked by another thread, the thread attempting the lock will be suspended until the thread holding the lock releases it. [Mutex](#) objects are not required to allow recursive access.

5.80.2 Member Function Documentation

5.80.2.1 `const Error* Lock (void)`

Lock the mutex.

This function causes the calling function to gain exclusive access to the mutex object. If some other thread has the mutex locked when this method is called, the calling thread will block until the mutex is unlocked.

Returns

An error object.

5.80.2.2 `const Error* Unlock (void)`

Unlock the mutex.

This function causes the calling thread to give up its lock on the mutex. A task switch may occur before this call returns if a high priority task is currently trying to lock the mutex.

Returns

An error object.

The documentation for this class was generated from the following file:

- [CML_Threads.h](#)

5.81 MutexLocker Class Reference

This is a utility class that locks a mutex in its constructor, and unlocks it in its destructor.

Public Member Functions

- [MutexLocker \(Mutex &m\)](#)

Lock the passed mutex.

- [~MutexLocker \(\)](#)

Unlock the mutex.

5.81.1 Detailed Description

This is a utility class that locks a mutex in it's constructor, and unlocks it in it's destructor.

It can be used to ensure that a mutex is properly unlocked when a function returns. Just create a temporary [MutexLocker](#) object and pass it the mutex to lock in it's constructor. The mutex will be automatically unlocked when the function returns and the [MutexLocker](#) is deleted.

5.81.2 Constructor & Destructor Documentation

5.81.2.1 `MutexLocker (Mutex & m) [inline]`

Lock the passed mutex.

Parameters

<i>m</i>	The mutex to lock.
----------	--------------------

The documentation for this class was generated from the following file:

- [CML_Threads.h](#)

5.82 Network Class Reference

Abstract network class.

Inheritance diagram for Network:

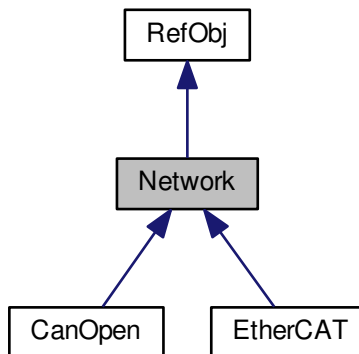

Collaboration diagram for Network:

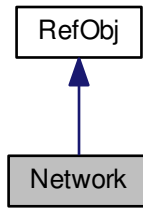

Public Member Functions

- virtual `int32 maxSdoToNode (Node *n)`
Return the maximum number of bytes that can be sent in an SDO message.
- virtual `int32 maxSdoFromNode (Node *n)`
Return the maximum number of bytes that can be received in an SDO message.

Static Protected Member Functions

- static `NetworkNodeInfo * GetNodeInfo (Node *n)`
Return a pointer to the network information union embedded in this node.
- static void `SetNodeInfo (Node *n, NetworkNodeInfo *ni)`
Set the network's node information for this node.

Additional Inherited Members

5.82.1 Detailed Description

Abstract network class.

This class forms the root of all the different networks that are supported by CML. Every device managed by CML is associated with exactly one network object. The network object manages some high level aspects of the communications with the device.

5.82.2 Member Function Documentation

5.82.2.1 `NetworkNodeInfo * GetNodeInfo (Node * n)` `[static]`, `[protected]`

Return a pointer to the network information union embedded in this node.

This union contains data related to the node that is owned by the network layer object.

Parameters

<i>n</i>	Pointer to the node object
----------	----------------------------

Returns

Pointer to the node information

5.82.2.2 int32 maxSdoFromNode (Node * *n*) [virtual]

Return the maximum number of bytes that can be received in an [SDO](#) message.

For CANopen this is always 8 (the max size of a CAN frame). For [EtherCAT](#) it's the size of the mailbox buffer, and is node specific

Parameters

<i>n</i>	The node to query
----------	-------------------

Returns

The maximum number of bytes in an [SDO](#) receive message

Reimplemented in [EtherCAT](#).

5.82.2.3 int32 maxSdoToNode (Node * *n*) [virtual]

Return the maximum number of bytes that can be sent in an [SDO](#) message.

For CANopen this is always 8 (the max size of a CAN frame). For [EtherCAT](#) it's the size of the mailbox buffer, and is node specific

Parameters

<i>n</i>	The node to query
----------	-------------------

Returns

The maximum number of bytes in an [SDO](#) transmit message

Reimplemented in [EtherCAT](#).

5.82.2.4 void SetNodeInfo (Node * *n*, NetworkNodeInfo * *ni*) [static], [protected]

Set the network's node information for this node.

This function is used internally by the network classes.

Parameters

<i>n</i>	Pointer to the node to update
----------	-------------------------------

<i>ni</i>	Pointer to the node information
-----------	---------------------------------

The documentation for this class was generated from the following files:

- [CML_Network.h](#)
- [Network.cpp](#)

5.83 NetworkError Class Reference

This class holds the error codes that describe various Network error conditions.

Inheritance diagram for NetworkError:

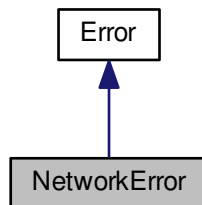

Collaboration diagram for NetworkError:

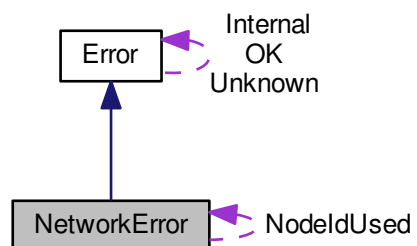

Static Public Attributes

- static const [NetworkError NodeIdUsed](#)

A node with the specified ID is already present on the network.

Additional Inherited Members

5.83.1 Detailed Description

This class holds the error codes that describe various Network error conditions.

The documentation for this class was generated from the following file:

- [CML_Network.h](#)

5.84 NetworkNodeInfo Class Reference

Private data owned by the network object attached to every node.

Inheritance diagram for NetworkNodeInfo:

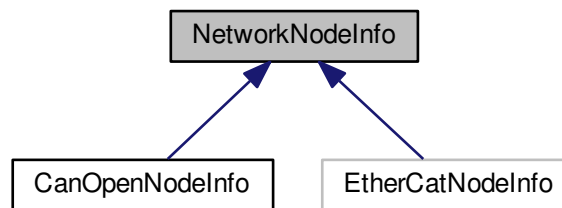

5.84.1 Detailed Description

Private data owned by the network object attached to every node.

The documentation for this class was generated from the following file:

- [CML_Network.h](#)

5.85 NetworkOptions Struct Reference

Configuration structure used to configure the amplifiers network support.

Public Member Functions

- [NetworkOptions](#) (void)

Default constructor.

Public Attributes

- [uint16 canBusConfig](#)
Network Options. The details fo this parameter depend on the type.

5.85.1 Detailed Description

Configuration structure used to configure the amplifiers network support.

These settings may be up/download from the amplifier using the functions [Amp::SetNetworkOptions](#) and [Amp::GetNetworkOptions](#).

5.85.2 Constructor & Destructor Documentation

5.85.2.1 `NetworkOptions(void) [inline]`

Default constructor.

Initialize all structure elements to zero.

The documentation for this struct was generated from the following file:

- [CML_AmpStruct.h](#)

5.86 Node Class Reference

[Node](#) class.

Inheritance diagram for Node:

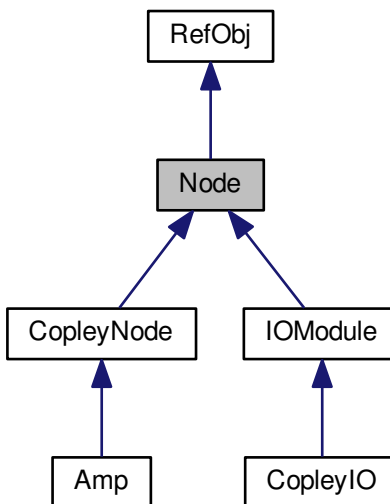

Collaboration diagram for Node:

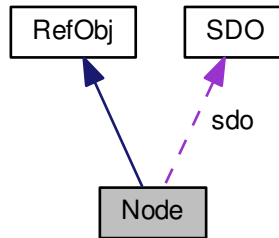

Public Member Functions

- [Node](#) ()
Default CANopen node object constructor.
- [Node](#) ([Network](#) &net, [int16](#) nodeID)
Initialize the [Node](#) object.
- virtual [~Node](#) ()
CANopen node destructor.
- virtual const [Error](#) * [StopGuarding](#) (void)
Disable node guarding & heartbeat monitoring.
- virtual const [Error](#) * [StartHeartbeat](#) ([uint16](#) period, [uint16](#) timeout)
Enable heartbeat messages from this node, and start a thread to monitor them.
- virtual const [Error](#) * [StartNodeGuard](#) ([uint16](#) guardTime, [byte](#) lifeFactor)
Enable node guarding on this node.
- virtual const [Error](#) * [Init](#) ([Network](#) &co, [int16](#) nodeID)
Initialize the CANopen [Node](#) object.
- virtual const [Error](#) * [UnInit](#) (void)
Un-initialize the [Node](#) object.
- virtual [NetworkType](#) [GetNetworkType](#) (void)
Return a value that identifies the type of network the node is currently attached to.
- virtual [uint32](#) [GetNetworkRef](#) (void)
Return a reference ID to the network that this node is attached to.
- virtual const [Error](#) * [PdoSet](#) ([uint16](#) n, [PDO](#) &pdo, bool enable=true)
Associate the passed [PDO](#) object with this node.
- virtual const [Error](#) * [PdoEnable](#) ([uint16](#) n, [PDO](#) &pdo)
Enable the passed [PDO](#) object.
- virtual const [Error](#) * [PdoDisable](#) ([uint16](#) n, [PDO](#) &pdo)
Disable the passed [PDO](#) object.
- virtual const [Error](#) * [RpdoDisable](#) ([uint16](#) n)
Disable the specified receive [PDO](#).
- virtual const [Error](#) * [TpdoDisable](#) ([uint16](#) n)

- Disable the specified transmit PDO.*

 - virtual const [Error](#) * [StartNode](#) (void)

Start this node.
- virtual const [Error](#) * [StopNode](#) (void)

Stop this node.
- virtual const [Error](#) * [PreOpNode](#) (void)

Put this node in pre-operational state.
- virtual const [Error](#) * [ResetNode](#) (void)

Reset this node.
- virtual const [Error](#) * [ResetComm](#) (void)

Reset this node's communications.
- virtual [NodeState](#) [GetState](#) (void)

Returns the present state of this node.
- virtual const [Error](#) * [GetDeviceType](#) (uint32 &devType)

Read the device type from the object dictionary.
- virtual const [Error](#) * [GetErrorRegister](#) (byte &err)

Read the error register from the object dictionary.
- virtual const [Error](#) * [GetMfgStatus](#) (uint32 &stat)

Read the manufacturer status register from the object dictionary.
- virtual const [Error](#) * [GetErrorHistory](#) (uint16 &ct, uint32 *array)

Get the error history array (CANopen object 0x1003).
- virtual const [Error](#) * [ClearErrorHistory](#) (void)

Clear the error history (object 0x1003) array for this node.
- virtual const [Error](#) * [GetMfgDeviceName](#) (int32 &len, char *str)

Read the manufacturer's device name string from the object dictionary.
- virtual const [Error](#) * [GetMfgHardwareVer](#) (int32 &len, char *str)

Read the manufacturer's Hardware version string from the object dictionary.
- virtual const [Error](#) * [GetMfgSoftwareVer](#) (int32 &len, char *str)

Read the manufacturer's software version string from the object dictionary.
- virtual const [Error](#) * [GetIdentity](#) (NodeIdentity &id)

Get the CANopen identity object for this node (object dictionary entry 0x1018).
- virtual const [Error](#) * [SetSynchId](#) (uint32 id)

Set the COB-ID of the synch message.
- virtual const [Error](#) * [GetSynchId](#) (uint32 &id)

Return the COB-ID of the synch message.
- virtual const [Error](#) * [SetSynchPeriod](#) (uint32 per)

Set the SYNC message interval in microseconds.
- virtual const [Error](#) * [GetSynchPeriod](#) (uint32 &per)

Get the SYNC message interval in microseconds.
- virtual const [Error](#) * [SynchStart](#) (void)

Start producing SYNC messages on this node.
- virtual const [Error](#) * [SynchStop](#) (void)

Stop producing SYNC messages on this node.
- virtual [int16](#) [GetNodeID](#) (void)

Return the node ID associated with this node.
- bool [IsInitialized](#) (void)

Return true if this node object has been initialized.

- virtual [int32 maxSdoToNode](#) (void)
Return the maximum number of bytes that can be sent in an [SDO](#) message.
- virtual [int32 maxSdoFromNode](#) (void)
Return the maximum number of bytes that can be received in an [SDO](#) message.

Public Attributes

- [SDO sdo](#)
This [SDO](#) may be used to get/set values in the node's object dictionary.

Protected Member Functions

- virtual void [HandleEmergency](#) ([CanFrame](#) &frame)
Overload this function to handle emergency objects sent by this node.
- virtual void [HandleStateChange](#) ([NodeState](#) from, [NodeState](#) to)
Overload this function to handle changes to the nodes state.

Friends

- class **Network**
- class **CanOpen**
- class **EtherCAT**

Additional Inherited Members

5.86.1 Detailed Description

[Node](#) class.

Objects of this class represent individual nodes on the CANopen or [EtherCAT](#) network.

5.86.2 Constructor & Destructor Documentation

5.86.2.1 [Node](#) ()

Default CANopen node object constructor.

This constructor simple marks the object as uninitialized. The [Init\(\)](#) function must be called before this object can be used.

5.86.2.2 [Node](#) ([Network](#) & net, int16 nodeID)

Initialize the [Node](#) object.

Parameters

<i>net</i>	The network object that this node is associated with.
<i>nodeID</i>	The node's ID.

5.86.3 Member Function Documentation

5.86.3.1 `virtual const Error* ClearErrorHistory (void) [inline],[virtual]`

Clear the error history (object 0x1003) array for this node.

Returns

An error object.

5.86.3.2 `virtual const Error* GetDeviceType (uint32 & devType) [inline],[virtual]`

Read the device type from the object dictionary.

Parameters

<i>devType</i>	Where the device type is returned
----------------	-----------------------------------

Returns

An error object

5.86.3.3 `const Error * GetErrorHistory (uint16 & ct, uint32 * array) [virtual]`

Get the error history array (CANopen object 0x1003).

Parameters

<i>ct</i>	When the function is first called, this variable holds the maximum number of errors that can be stored in the err array (i.e. the length of the array). On return, the actual number of errors uploaded will be stored here.
<i>array</i>	An array of 32-bit integers that will be used to return the list of errors.

Returns

A pointer to an error object, or NULL on success

5.86.3.4 `virtual const Error* GetErrorRegister (byte & err) [inline],[virtual]`

Read the error register from the object dictionary.

Parameters

<i>err</i>	Reference to where the error should be returned.
------------	--

Returns

An error object

5.86.3.5 `const Error* GetIdentity (NodeIdentity & id) [virtual]`

Get the CANopen identity object for this node (object dictionary entry 0x1018).

Note that only the VendorID field is mandatory. Any unsupported fields will be returned as zero.

Parameters

<i>id</i>	The identity object to be filled in by this call
-----------	--

Returns

A pointer to an error object, or NULL on success

5.86.3.6 `virtual const Error* GetMfgDeviceName (int32 & len, char * str) [inline],[virtual]`

Read the manufacturer's device name string from the object dictionary.

Parameters

<i>len</i>	Holds the size of the buffer on entry, and the length of the downloaded data on return.
<i>str</i>	An array of characters used to upload the string.

Returns

An error object

5.86.3.7 `virtual const Error* GetMfgHardwareVer (int32 & len, char * str) [inline],[virtual]`

Read the manufacturer's Hardware version string from the object dictionary.

Parameters

<i>len</i>	Holds the size of the buffer on entry, and the length of the downloaded data on return.
<i>str</i>	An array of characters used to upload the string.

Returns

An error object

5.86.3.8 `virtual const Error* GetMfgSoftwareVer (int32 & len, char * str) [inline],[virtual]`

Read the manufacturer's software version string from the object dictionary.

Parameters

<i>len</i>	Holds the size of the buffer on entry, and the length of the downloaded data on return.
<i>str</i>	An array of characters used to upload the string.

Returns

An error object

5.86.3.9 `virtual const Error* GetMfgStatus (uint32 & stat) [inline],[virtual]`

Read the manufacturer status register from the object dictionary.

Parameters

<i>stat</i>	Reference to the int32 where the status will be returned
-------------	--

Returns

An error object

5.86.3.10 `uint32 GetNetworkRef (void) [virtual]`

Return a reference ID to the network that this node is attached to.

Returns

The reference ID or 0 if the node isn't attached to any network.

Reimplemented in [Amp](#).

5.86.3.11 `NetworkType GetNetworkType (void) [virtual]`

Return a value that identifies the type of network the node is currently attached to.

Returns

A network type value, or NET_TYPE_INVALID if the node isn't attached to any network.

5.86.3.12 `virtual int16 GetNodeID (void) [inline],[virtual]`

Return the node ID associated with this node.

Returns

The node ID

5.86.3.13 `virtual NodeState GetState (void) [inline],[virtual]`

Returns the present state of this node.

Note that this requires node guarding or heartbeats to be enabled.

Returns

The present node state.

Reimplemented in [Amp](#).

5.86.3.14 `virtual const Error* GetSynchId (uint32 & id) [inline],[virtual]`

Return the COB-ID of the synch message.

Note that if this node is producing the synch message, bit 30 will be set.

Parameters

<i>id</i>	Where the COB-ID is returned
-----------	------------------------------

Returns

An error object.

5.86.3.15 `virtual const Error* GetSynchPeriod (uint32 & per) [inline],[virtual]`

Get the SYNC message interval in microseconds.

Parameters

<i>per</i>	Period will be returned here
------------	------------------------------

Returns

An error object.

5.86.3.16 `virtual void HandleEmergency (CanFrame & frame) [inline],[protected],[virtual]`

Overload this function to handle emergency objects sent by this node.

Parameters

<i>frame</i>	Reference to the CAN frame holding the emergency data.
--------------	--

5.86.3.17 `virtual void HandleStateChange (NodeState from, NodeState to) [inline],[protected],[virtual]`

Overload this function to handle changes to the nodes state.

Note that the state member variable will have been changed to the new state before this function is called.

Parameters

<i>from</i>	Previous node state before the change
<i>to</i>	New node state

Reimplemented in [Amp](#).

5.86.3.18 `const Error * Init (Network & network, int16 nodeID) [virtual]`

Initialize the CANopen [Node](#) object.

Note that a CANopen node object must be initialized once and only once. This function should be used to initialize the object if it was created using the default constructor.

Parameters

<i>network</i>	The network object that this node is associated with.
<i>nodeID</i>	The node's ID. A value that identifies this node on the network.

Returns

A pointer to an error object, or NULL on success

Reimplemented in [Amp](#), [IOModule](#), and [CopleyIO](#).

5.86.3.19 `int32 maxSdoFromNode(void) [virtual]`

Return the maximum number of bytes that can be received in an [SDO](#) message.

For CANopen this is always 8 (the max size of a CAN frame). For [EtherCAT](#) it's the size of the mailbox buffer, and is node specific

Returns

The maximum number of bytes in an [SDO](#) receive message, or 0 on error

5.86.3.20 `int32 maxSdoToNode(void) [virtual]`

Return the maximum number of bytes that can be sent in an [SDO](#) message.

For CANopen this is always 8 (the max size of a CAN frame). For [EtherCAT](#) it's the size of the mailbox buffer, and is node specific

Returns

The maximum number of bytes in an [SDO](#) transmit message, or 0 on error

5.86.3.21 `const Error * PdoDisable (uint16 n, PDO & pdo) [virtual]`

Disable the passed [PDO](#) object.

Parameters

<i>n</i>	The slot number of the PDO
<i>pdo</i>	The PDO mapped to that slot

Returns

An error object

5.86.3.22 `const Error * PdoEnable (uint16 n, PDO & pdo) [virtual]`

Enable the passed [PDO](#) object.

Parameters

<i>n</i>	The slot number of the PDO
<i>pdo</i>	The PDO mapped to that slot

Returns

An error object

5.86.3.23 `const Error * PdoSet (uint16 slot, PDO & pdo, bool enable = true) [virtual]`

Associate the passed [PDO](#) object with this node.

The [PDO](#) will be setup as this node's nth [PDO](#).

Parameters

<i>slot</i>	Which PDO slot to assign this PDO to.
<i>pdo</i>	The PDO object.
<i>enable</i>	If true, the PDO will be enabled after being setup (default). If false, the PDO will be setup but not enabled.

Returns

A pointer to an error object, or NULL on success

5.86.3.24 `const Error * PreOpNode (void) [virtual]`

Put this node in pre-operational state.

Returns

An error object or null on success.

5.86.3.25 `const Error * ResetComm (void) [virtual]`

Reset this node's communications.

Returns

An error object or null on success.

5.86.3.26 `const Error * ResetNode (void) [virtual]`

Reset this node.

Returns

An error object

5.86.3.27 `const Error * RpdoDisable (uint16 n) [virtual]`

Disable the specified receive [PDO](#).

Parameters

<i>n</i>	The slot number of the PDO
----------	--

Returns

An error object

5.86.3.28 `virtual const Error* SetSynchId (uint32 id) [inline],[virtual]`

Set the COB-ID of the synch message.

If bit 30 of the ID is set, then this node will be the synch producer.

Parameters

<i>id</i>	COB-ID to set
-----------	---------------

Returns

An error object

5.86.3.29 `virtual const Error* SetSynchPeriod (uint32 per) [inline],[virtual]`

Set the SYNC message interval in microseconds.

Parameters

<i>per</i>	The period in microseconds.
------------	-----------------------------

Returns

An error object.

5.86.3.30 `const Error * StartHeartbeat (uint16 period, uint16 timeout) [virtual]`

Enable heartbeat messages from this node, and start a thread to monitor them.

Parameters

<i>period</i>	The producer timeout value (milliseconds). The node will be configured to produce a heartbeat message at this interval.
<i>timeout</i>	The additional number of milliseconds that the monitor thread will wait before indicating an error. Thus, the consumer heartbeat interval will be (period + timeout).

Returns

A pointer to an error object, or NULL on success

5.86.3.31 `const Error * StartNode (void) [virtual]`

Start this node.

Returns

An error object or null on success.

5.86.3.32 `const Error * StartNodeGuard (uint16 guardTime, byte lifeFactor) [virtual]`

Enable node guarding on this node.

When node guarding is enabled, a new thread is created which will send a remote request to this node every (guardTime) milliseconds. The node must respond to this message within the guard time. If the node does not respond then the thread will notify the node of a state change.

Parameters

<i>guardTime</i>	The period in milliseconds of the guard messages sent to the node. It can range from 1 to 65535.
<i>lifeFactor</i>	A multiplier used by the node to determine how long to wait for a node guarding message from the host before indicating a local error. The nodes timeout (life time) is guardTime * lifeFactor. This parameter must be between 0 and 255. If it's zero, then life guarding on the node is disabled.

Returns

A pointer to an error object, or NULL on success

5.86.3.33 `const Error * StopGuarding (void) [virtual]`

Disable node guarding & heartbeat monitoring.

Returns

A pointer to an error object, or NULL on success

5.86.3.34 `const Error * StopNode (void) [virtual]`

Stop this node.

Returns

An error object or null on success.

5.86.3.35 `const Error * SynchStart (void) [virtual]`

Start producing SYNC messages on this node.

Returns

An error object.

5.86.3.36 `const Error * SynchStop (void) [virtual]`

Stop producing SYNC messages on this node.

Returns

An error object.

5.86.3.37 `const Error * TpdoDisable (uint16 n) [virtual]`

Disable the specified transmit PDO.

Parameters

<i>n</i>	The slot number of the PDO
----------	----------------------------

Returns

An error object

5.86.3.38 `const Error * Uninit (void) [virtual]`

Un-initialize the [Node](#) object.

This puts the object back to it's default state.

Returns

A pointer to an error object, or NULL on success.

5.86.4 Member Data Documentation

5.86.4.1 SDO sdo

This [SDO](#) may be used to get/set values in the node's object dictionary.

The documentation for this class was generated from the following files:

- [CML_Node.h](#)
- [Node.cpp](#)

5.87 NodeError Class Reference

This class represents node errors.

Inheritance diagram for NodeError:

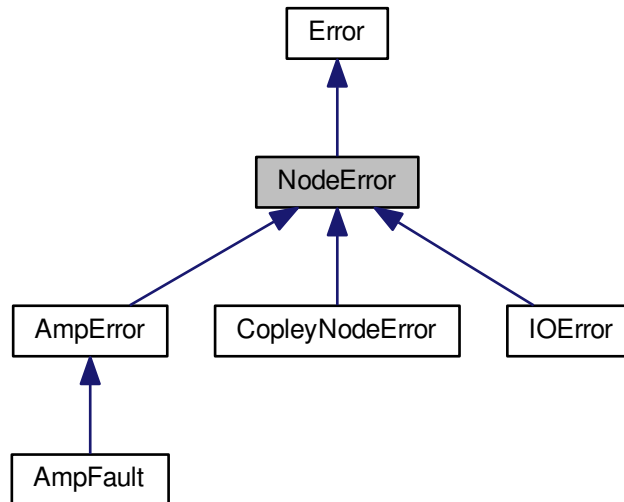

Collaboration diagram for NodeError:

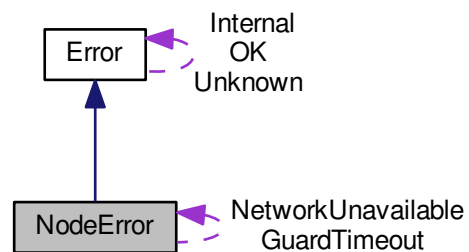

Static Public Attributes

- static const `NodeError GuardTimeout`
A node guarding or heartbeat timeout occurred.

- static const [NodeError NetworkUnavailable](#)

The network this node is connected to has been deleted.

Protected Member Functions

- [NodeError](#) (uint16 id, const char *desc)

Standard protected constructor.

Additional Inherited Members

5.87.1 Detailed Description

This class represents node errors.

There is one static member for each defined node error.

The documentation for this class was generated from the following file:

- [CML_Node.h](#)

5.88 NodeIdentity Struct Reference

CANopen identity object.

Public Attributes

- [uint32 vendorID](#)

A unique vendor ID assigned by CiA (Can in Automation)

- [uint32 productCode](#)

Manufacturer's product code.

- [uint32 revision](#)

Revision number which identifies CANopen functionality.

- [uint32 serial](#)

Product serial number.

5.88.1 Detailed Description

CANopen identity object.

Each node is required to include an identity object on it's object dictionary at location 0x1018. The only required parameter is the vendorID. All others are included at the manufacturer's discretion.

The documentation for this struct was generated from the following file:

- [CML_Node.h](#)

5.89 Path Class Reference

Multi-axis complex trajectory path.

Inheritance diagram for Path:

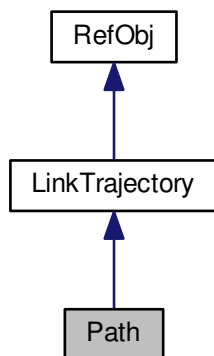

Collaboration diagram for Path:

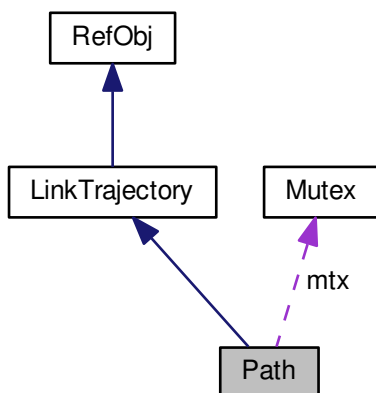

Public Member Functions

- [Path](#) (uint d)
Path object constructor.

- virtual `~Path` (void)
Destructor for the path object.
- virtual void `Reset` (void)
Reset the path to the first position.
- virtual const `Error` * `SetStartPos` (`PointN` &p)
Set the initial position for the path.
- virtual const `Error` * `SetVel` (uunit v)
Set the velocity limit for the current location.
- virtual const `Error` * `SetAcc` (uunit a)
Set the acceleration limit for the current location.
- virtual const `Error` * `SetDec` (uunit d)
Set the deceleration limit for the current location.
- virtual const `Error` * `SetJrk` (uunit j)
Set the jerk limit for the current location.
- virtual const `Error` * `AddLine` (`PointN` &p)
Add a line segment from the current position to the specified point.
- virtual const `Error` * `AddLine` (uunit length)
Add a line segment of the specified length.
- virtual const `Error` * `AddArc` (double radius, double angle)
Add an arc with the specified radius and angle (radians).
- virtual const `Error` * `AddArc` (`PointN` ¢er, double angle)
Add an arc with the specified center point and angle (radians).
- virtual const `Error` * `Pause` (double sec)
Set the current velocity to 0 and pause for the specified amount of time.
- virtual int `GetDim` (void)
Get the dimension (i.e.
- virtual const `Error` * `NextSegment` (uunit pos[], uunit vel[], uint8 &time)
Get the next trajectory segment.
- virtual const `Error` * `StartNew` (void)
Start a new trajectory.
- bool `PlayPath` (double timeInc, double pos[], double vel[])
Play back path data.

Additional Inherited Members

5.89.1 Detailed Description

Multi-axis complex trajectory path.

The object may be used to construct one or two dimensional trajectories built out of line segments and arcs.

5.89.2 Constructor & Destructor Documentation

5.89.2.1 `Path` (uint d)

`Path` object constructor.

The number of dimensions for the path must be passed. This object currently supports one and two dimensional (i.e. one and two axis) path construction.

Parameters

<i>d</i>	The number of dimensions for the path. Must be either one or two for now.
----------	---

5.89.3 Member Function Documentation

5.89.3.1 `virtual const Error* AddArc (double radius, double angle) [virtual]`

Add an arc with the specified radius and angle (radians).

The arc will start at the current position and will move in either a clockwise (positive angle), or counter-clockwise (negative angle) direction.

Parameters

<i>radius</i>	The radius of the arc
<i>angle</i>	The number of radians to rotate through. Positive values will result in clockwise rotation.

Returns

An error object or null on success

5.89.3.2 `virtual const Error* AddArc (PointN & center, double angle) [virtual]`

Add an arc with the specified center point and angle (radians).

The arc will start at the current position and will move in clockwise (positive angle), or counter-clockwise (negative angle) direction.

Parameters

<i>center</i>	The center point of the arc.
<i>angle</i>	The number of radians to rotate through. Positive values will result in clockwise rotation.

Returns

An error object or null on success

5.89.3.3 `virtual const Error* AddLine (PointN & p) [virtual]`

Add a line segment from the current position to the specified point.

The direction of motion required to move from the current position to the given point will be compared to the direction of motion at the end of the last segment. If these directions change then the addition of this new point will require an abrupt change of direction. In this case, the initial velocity will be set to zero.

Parameters

<i>p</i>	The point to move to.
----------	-----------------------

Returns

An error object or null on success

5.89.3.4 `virtual const Error* AddLine (uunit length) [virtual]`

Add a line segment of the specified length.

The direction of motion will remain the same as it was at the end of the last added segment. If this is the first segment added to the path, then the direction will be positive motion in the first axis.

Parameters

<i>length</i>	The length of the line segment to add.
---------------	--

Returns

An error object or null on success

5.89.3.5 `virtual int GetDim (void) [virtual]`

Get the dimension (i.e. number of axes) of the path.

Returns

The path dimension

Implements [LinkTrajectory](#).

5.89.3.6 `virtual const Error* NextSegment (uunit pos[], uunit vel[], uint8 & time) [virtual]`

Get the next trajectory segment.

This method is called by the [Linkage](#) object when as it passes the trajectory information up to the amplifiers.

Parameters

<i>pos</i>	An array where the position values will be returned. This array will be at least D elements long, where D is the trajectory dimension as returned by LinkTrajectory::GetDim()
<i>vel</i>	An array where the velocity values will be returned.
<i>time</i>	The segment time is returned here. This is in milliseconds and ranges from 1 to 255. If zero is returned, this is the last frame in the profile.

Returns

A pointer to an error object on failure, or NULL on success.

Implements [LinkTrajectory](#).

5.89.3.7 `virtual const Error* Pause (double sec) [virtual]`

Set the current velocity to 0 and pause for the specified amount of time.

Parameters

<i>sec</i>	The time to pause (must be ≥ 0). Time is specified in seconds.
------------	--

Returns

An error object or null on success

5.89.3.8 `bool PlayPath (double timeInc, double pos[], double vel[])`

Play back path data.

This method may be used to iterate through a path for display purposes.

Before starting a path playback, the path should be reset using the method [Path::Reset](#).

Each call to this function will return position and velocity information for the current playback position in the path. It will then increment the playback position by the time value passed. When the end of the path is reached, the method will return true.

Parameters

<i>timeInc</i>	The amount of time (seconds) to increment the playback position after reading out the position & velocity values.
<i>pos</i>	An array where the position information will be returned. This array must be long enough to store DIM elements, where DIM is the path dimension.
<i>vel</i>	An array where the velocity information will be returned. This array must be long enough to store DIM elements, where DIM is the path dimension.

Returns

true if the end of the path has been reached, false if not.

5.89.3.9 `virtual void Reset (void) [virtual]`

Reset the path to the first position.

This should be called before the path is passed to the [Linkage](#) object as a trajectory to run.

5.89.3.10 `virtual const Error* SetAcc (uunit a) [virtual]`

Set the acceleration limit for the current location.

Acceleration limits must be greater than zero.

Parameters

<i>a</i>	The maximum acceleration (position units / second / second)
----------	---

Returns

An error object or null on success

5.89.3.11 virtual const Error* SetDec (uunit *d*) [virtual]

Set the deceleration limit for the current location.

Note that setting the deceleration limit less then or equal to zero will cause the acceleration value to be used for deceleration also.

Parameters

<i>d</i>	The maximum deceleration (position units / second / second)
----------	---

Returns

An error object or null on success

5.89.3.12 virtual const Error* SetJrk (uunit *j*) [virtual]

Set the jerk limit for the current location.

Note that setting the jerk limit to a value less then or equal to zero will cause the path to be calculated with no jerk limiting.

Parameters

<i>j</i>	The jerk limit (position units / second / second / second)
----------	--

Returns

An error object or null on success.

5.89.3.13 virtual const Error* SetStartPos (PointN & *p*) [virtual]

Set the initial position for the path.

This method may be used to start a path at a position other then (0,0) which is the default if no starting position is set.

The starting position may be set at any time, either before or after adding segments to the path. Internally, the segments are all stored as relative positions.

Parameters

<i>p</i>	The starting position for this path.
----------	--------------------------------------

Returns

An error object or null on success

5.89.3.14 virtual const Error* SetVel (uunit *v*) [virtual]

Set the velocity limit for the current location.

Velocity limits must be greater then zero.

Parameters

v	The maximum velocity (position units / second)
---	--

Returns

An error object or null on success

5.89.3.15 `virtual const Error* StartNew (void) [virtual]`

Start a new trajectory.

This function is called before the first call to [LinkTrajectory::NextSegment](#). It will result in a call to [Path::Reset](#)

Returns

An error pointer if the trajectory object is not available, or NULL if it is ready to be sent.

Reimplemented from [LinkTrajectory](#).

The documentation for this class was generated from the following file:

- CML_Path.h

5.90 PathError Class Reference

This class represents errors returned by the path [Path](#) object.

Inheritance diagram for PathError:

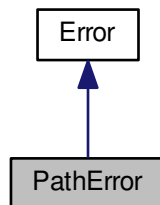

Collaboration diagram for PathError:

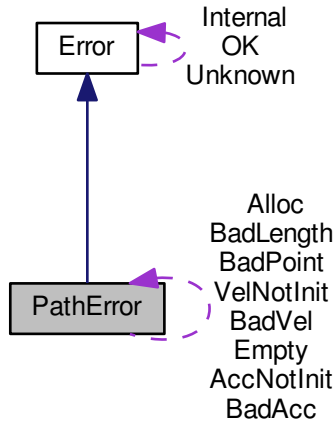

Static Public Attributes

- static const [PathError BadVel](#)
Illegal velocity value.
- static const [PathError BadAcc](#)
Illegal acceleration value.
- static const [PathError VelNotInit](#)
Velocity limit not yet set.
- static const [PathError AccNotInit](#)
Acceleration limit not yet set.
- static const [PathError BadPoint](#)
The passed point doesn't match the path.
- static const [PathError Alloc](#)
Unable to allocate memory for path.
- static const [PathError BadLength](#)
An illegal negative length value was passed.
- static const [PathError Empty](#)
Attempt to execute an empty path.

Protected Member Functions

- [PathError](#) (uint16 id, const char *desc)
Standard protected constructor.

Additional Inherited Members

5.90.1 Detailed Description

This class represents errors returned by the path [Path](#) object.

The documentation for this class was generated from the following file:

- CML_Path.h

5.91 PcapEcatHardware Class Reference

This class provides an interface to the Ethernet ports on a Windows system using the winpcap library.

Inheritance diagram for PcapEcatHardware:

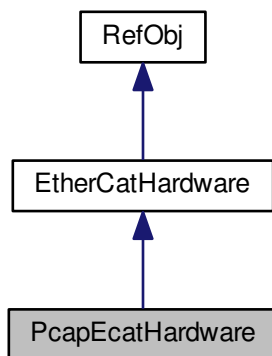

Collaboration diagram for PcapEcatHardware:

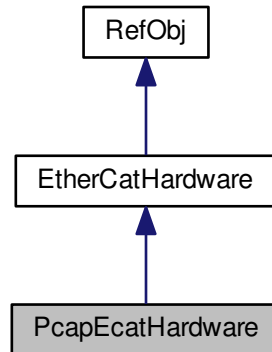

Public Member Functions

- `PcapEcatHardware` (const char *name=0)
Create an [EtherCAT](#) hardware interface which uses the pcap library to capture packets.
- const char * `GetAdapterName` (int index)
Return the name of the Nth [EtherCAT](#) adapter available in the system.
- const char * `GetAdapterDesc` (int index)
Return a description of the Nth [EtherCAT](#) adapter available in the system.

Additional Inherited Members

5.91.1 Detailed Description

This class provides an interface to the Ethernet ports on a Windows system using the winpcap library. Support for winpcap is now deprecated in CML. Please use the [WinUdpEcatHardware](#) class instead.

5.91.2 Constructor & Destructor Documentation

5.91.2.1 `PcapEcatHardware (const char * name = 0)`

Create an [EtherCAT](#) hardware interface which uses the pcap library to capture packets.

This module also supports the winpcap library on Windows. Please see <http://www.winpcap.org> for more information.

Parameters

<i>name</i>	The parameter identifies the Ethernet adapter to open. This parameter can either be the name of an EtherNet port as returned by the pcap call <code>pcap_findalldevs</code> , or it can take the form <code>ethN</code> for some integer N (i.e. <code>eth0</code> , <code>eth1</code> , etc). In this case the Nth Ethernet port identified by the pcap library will be used.
-------------	--

If NULL is passed (default), then the first Ethernet adapter will be used.

5.91.3 Member Function Documentation

5.91.3.1 `const char * GetAdapterDesc (int index)`

Return a description of the Nth [EtherCAT](#) adapter available in the system.

Parameters

<i>index</i>	Identifies which adapter name to return.
--------------	--

Returns

A locally allocated buffer holding the description, or NULL if there is no description available. It's possible that a valid device number may not have a description available, so a NULL returned here does not necessarily indicate the lack of a device.

5.91.3.2 `const char * GetAdapterName (int index)`

Return the name of the Nth [EtherCAT](#) adapter available in the system.

Parameters

<i>index</i>	Identifies which adapter name to return.
--------------	--

Returns

A locally allocated buffer holding the name, or NULL if there are no remaining adapters available. The returned buffer is owned by the class and will be updated on subsequent calls to this function.

The documentation for this class was generated from the following files:

- `ecat_pcap.h`
- `ecat_pcap.cpp`

5.92 PDO Class Reference

[PDO](#) (Process Data Object) base class.

Inheritance diagram for PDO:

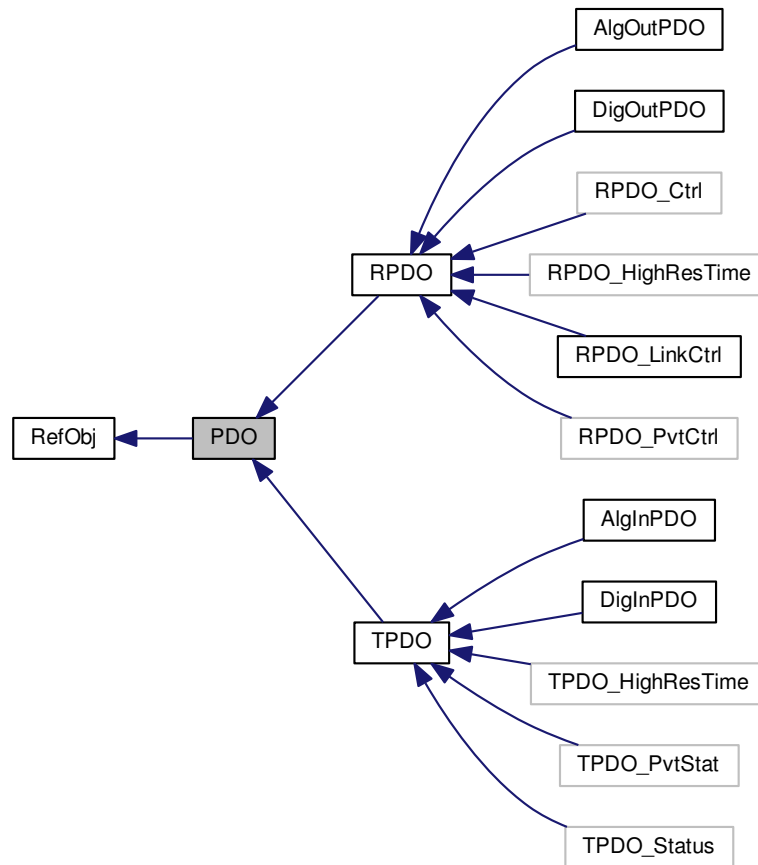

Collaboration diagram for PDO:

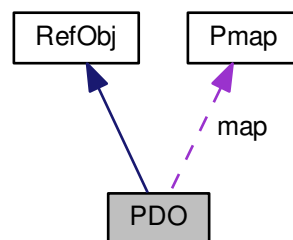

Public Member Functions

- [PDO](#) (void)
Default constructor. Simply initializes some variables.
- virtual [~PDO](#) ()
Virtual destructor.
- virtual bool [IsTxPDO](#) (void)=0
Return true for transmit PDOs and false for receive PDOs.
- virtual const [Error](#) * [SetID](#) (uint32 i)
Set the CAN message ID associated with the PDO.
- virtual uint32 [GetID](#) (void)
Get the CAN message ID associated with the PDO.
- virtual const [Error](#) * [SetType](#) (byte t)
Set the PDO transmission type code.
- virtual byte [GetType](#) (void)
Return the PDO transmission type associated with this PDO.
- virtual const [Error](#) * [ClearMap](#) (void)
Clear the variable map associated with this PDO.
- virtual const [Error](#) * [AddVar](#) (Pmap &var)
Add the passed variable to the end of the variable map associated with this PDO.
- virtual int [GetRtrOk](#) (void)
Return non-zero if RTR requests are OK for this PDO.
- virtual int [GetMapCodes](#) (uint32 codes[])
Fill the array of 32-bit ints with the PDO mapping codes used by this PDO.
- virtual int [GetBitCt](#) (void)
Return the length (in bits) of the data mapped to this PDO.

Protected Attributes

- [byte flags](#)
Misc flags associated with the PDO.
- [byte type](#)
Transmission type code.
- int [mapCt](#)
Number of elements in the variable map.
- int [bitCt](#)
Number of bits mapped so far.
- [Pmap](#) * [map](#) [PDO_MAP_LEN]
Array of pointers to Pmap objects that describe the variables transmitted by this PDO.
- uint32 [id](#)
The CAN message ID associated with this PDO.

Friends

- class [EtherCAT](#)

Additional Inherited Members

5.92.1 Detailed Description

[PDO](#) (Process Data Object) base class.

5.92.2 Member Function Documentation

5.92.2.1 `const Error * AddVar (Pmap & var) [virtual]`

Add the passed variable to the end of the variable map associated with this [PDO](#).

Parameters

<i>var</i>	The variable to be added.
------------	---------------------------

Returns

An error object.

5.92.2.2 `virtual const Error* ClearMap (void) [inline],[virtual]`

Clear the variable map associated with this [PDO](#).

Returns

An error code

5.92.2.3 `virtual uint32 GetID (void) [inline],[virtual]`

Get the CAN message ID associated with the [PDO](#).

Returns

The COB-ID of the [PDO](#)

5.92.2.4 `virtual int GetMapCodes (uint32 codes[]) [inline],[virtual]`

Fill the array of 32-bit ints with the [PDO](#) mapping codes used by this [PDO](#).

Parameters

<i>codes</i>	An array of at least PDO_MAP_LEN 32-bit ints. The mapping codes will be stored here
--------------	---

Returns

The number of elements mapped into this [PDO](#).

5.92.2.5 `virtual int GetRtrOk (void) [inline],[virtual]`

Return non-zero if RTR requests are OK for this [PDO](#).

Note that this only really makes sense for transmit PDOs

Returns

zero if RTR not allowed, non-zero if allowed.

5.92.2.6 `virtual byte GetType (void) [inline],[virtual]`

Return the [PDO](#) transmission type associated with this [PDO](#).

Returns

The 8-bit type code

5.92.2.7 `virtual const Error* SetID (uint32 i) [inline],[virtual]`

Set the CAN message ID associated with the [PDO](#).

Parameters

<i>i</i>	The ID value.
----------	---------------

Returns

An error object or NULL on success

5.92.2.8 `virtual const Error* SetType (byte t) [inline],[virtual]`

Set the [PDO](#) transmission type code.

Parameters

<i>t</i>	Transmission type code
----------	------------------------

Returns

An error object.

5.92.3 Member Data Documentation

5.92.3.1 `Pmap* map[PDO_MAP_LEN] [protected]`

[Array](#) of pointers to [Pmap](#) objects that describe the variables transmitted by this [PDO](#).

The documentation for this class was generated from the following files:

- [CML_PDO.h](#)
- [PDO.cpp](#)

5.93 PDO_Error Class Reference

This class represents error conditions related to PDOs.

Inheritance diagram for PDO_Error:

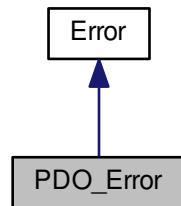

Collaboration diagram for PDO_Error:

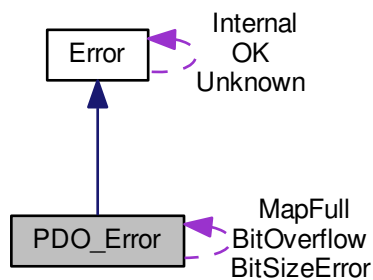

Static Public Attributes

- static const [PDO_Error MapFull](#)
The variable map associated with the PDO is already full.
- static const [PDO_Error BitOverflow](#)
Adding the variable to the map would cause the map to be too long (more than 64 bits).
- static const [PDO_Error BitSizeError](#)
PDO Map variables of the passed bit size are not presently supported.

Protected Member Functions

- [PDO_Error](#) ([uint16](#) id, const char *desc)

Standard protected constructor.

Additional Inherited Members

5.93.1 Detailed Description

This class represents error conditions related to PDOs.

5.93.2 Member Data Documentation

5.93.2.1 `const PDO_Error BitOverflow` [static]

Adding the variable to the map would cause the map to be too long (more then 64 bits).

The documentation for this class was generated from the following file:

- [CML_PDO.h](#)

5.94 Pmap Class Reference

This class allows variables to be mapped into a [PDO](#).

Inheritance diagram for Pmap:

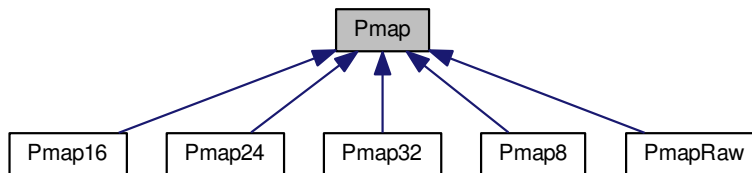

Public Member Functions

- [Pmap](#) ()
Default constructor for a generic [PDO](#) mapping variable.
- [Pmap](#) (uint16 index, byte sub, byte bits)
Construct a generic [PDO](#) mapping variable and initialize it's size and object ID.
- virtual [~Pmap](#) ()
Virtual destructor.
- virtual const [Error](#) * [Init](#) (uint16 index, byte sub, byte bits)
Initialize a generic [PDO](#) mapping variable.
- virtual void [Get](#) (byte *cptr)
Called when a receive [PDO](#) is about to be transmitted.

- virtual void `Set (byte *cptr)`
Called when a transmit PDO is received.
- virtual `uint32 GetMapCode ()`
Return the 32-bit code used to identify this variable in the CANopen node's PDO mapping block.
- `uint16 GetIndex ()`
Get the object index associated with this variable.
- `byte GetSub ()`
Get the object sub-index associated with this variable.
- `byte GetBits ()`
Get the number of bits in this variable.

Protected Attributes

- `uint16 index`
The 16-bit index of the object in the object dictionary.
- `byte sub`
The 8-bit sub-index of the object in the object dictionary.
- `byte bits`
The number of bits that this object takes up.

5.94.1 Detailed Description

This class allows variables to be mapped into a [PDO](#).

This class can be used directly for transmit PDOs if the received data is not of interest (it will simply be discarded by the `Set()` function). Using this for receive PDOs is not recommended since the `Get()` function doesn't add any data to the output stream and therefore the data transmitted to the node will be undefined.

5.94.2 Constructor & Destructor Documentation

5.94.2.1 `Pmap (uint16 index, byte sub, byte bits)` `[inline]`

Construct a generic [PDO](#) mapping variable and initialize it's size and object ID.

Parameters

<i>index</i>	The index of the variable in the object dictionary
<i>sub</i>	The variable's sub-index in the object dictionary
<i>bits</i>	The size of the variable in bits

5.94.3 Member Function Documentation

5.94.3.1 `virtual void Get (byte * cptr)` `[inline]`, `[virtual]`

Called when a receive [PDO](#) is about to be transmitted.

This virtual function does nothing and therefore objects of this generic type shouldn't be used when actually transmitting PDOs

Parameters

<i>ctr</i>	Pointer where the PDO data should be stored
------------	---

Reimplemented in [Pmap8](#), [Pmap16](#), [Pmap24](#), [Pmap32](#), and [PmapRaw](#).

5.94.3.2 `byte GetBits () [inline]`

Get the number of bits in this variable.

Returns

The number of bits.

5.94.3.3 `uint16 GetIndex () [inline]`

Get the object index associated with this variable.

Returns

The 16-bit object index.

5.94.3.4 `byte GetSub () [inline]`

Get the object sub-index associated with this variable.

Returns

The 8-bit object sub-index.

5.94.3.5 `virtual const Error* Init (uint16 index, byte sub, byte bits) [inline],[virtual]`

Initialize a generic PDO mapping variable.

Parameters

<i>index</i>	The index of the variable in the object dictionary
<i>sub</i>	The variable's sub-index in the object dictionary
<i>bits</i>	The size of the variable in bits

Returns

An error object

5.94.3.6 `virtual void Set (byte * ctr) [inline],[virtual]`

Called when a transmit PDO is received.

This virtual function doesn't do anything and therefore objects of this base class should only be used for variables that are not of interest and can therefore be ignored.

Parameters

<i>ptr</i>	Pointer to the received PDO data.
------------	---

Reimplemented in [Pmap8](#), [Pmap16](#), [Pmap24](#), [Pmap32](#), and [PmapRaw](#).

The documentation for this class was generated from the following file:

- [CML_PDO.h](#)

5.95 Pmap16 Class Reference

This is a [PDO](#) variable mapping class that extends the virtual [Pmap](#) class to handle 16-bit integers.

Inheritance diagram for Pmap16:

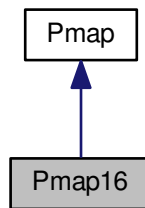

Collaboration diagram for Pmap16:

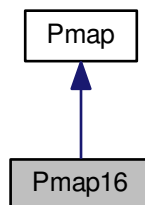

Public Member Functions

- [Pmap16 \(\)](#)
Default constructor for a 16-bit mapping object.
- [Pmap16 \(uint16 index, byte sub=0\)](#)

Create a new 16-bit mapping object.

- const **Error** * **Init** (uint16 index, byte sub=0)

Initialize a 16-bit mapping object.

- virtual void **Get** (byte *cptr)

Copy the current value of this variable into the passed character array.

- virtual void **Set** (byte *cptr)

Update the value of this variable based on the data passed in a character array.

- virtual int16 **Read** (void)

Read the current value of this variable.

- virtual void **Write** (int16 d)

Write a new value to this variable.

Additional Inherited Members

5.95.1 Detailed Description

This is a [PDO](#) variable mapping class that extends the virtual [Pmap](#) class to handle 16-bit integers.

5.95.2 Constructor & Destructor Documentation

5.95.2.1 Pmap16 (uint16 index, byte sub = 0) [inline]

Create a new 16-bit mapping object.

Parameters

<i>index</i>	Object index associated with this variable
<i>sub</i>	Object sub-index (defaults to 0)

5.95.3 Member Function Documentation

5.95.3.1 virtual void Get (byte * cptr) [inline],[virtual]

Copy the current value of this variable into the passed character array.

This function is called when a receive [PDO](#) is about to be transmitted to a node.

Parameters

<i>cptr</i>	A character pointer that references a char array of at least 2 bytes. The current value of this variable will be copied there.
-------------	--

Reimplemented from [Pmap](#).

5.95.3.2 const Error* Init (uint16 index, byte sub = 0) [inline]

Initialize a 16-bit mapping object.

Parameters

<i>index</i>	Object index associated with this variable
<i>sub</i>	Object sub-index (defaults to 0)

Returns

An error object

5.95.3.3 `virtual int16 Read (void) [inline],[virtual]`

Read the current value of this variable.

Returns

The current value of this variable.

5.95.3.4 `virtual void Set (byte * cptr) [inline],[virtual]`

Update the value of this variable based on the data passed in a character array.

This function is called when a transmit [PDO](#) that this variable is mapped to is received.

Parameters

<i>cptr</i>	A character pointer that references a char array of at least 2 bytes. The value of this variable will be updated with the data passed in this array.
-------------	--

Reimplemented from [Pmap](#).

5.95.3.5 `virtual void Write (int16 d) [inline],[virtual]`

Write a new value to this variable.

Parameters

<i>d</i>	The new value to write.
----------	-------------------------

The documentation for this class was generated from the following file:

- [CML_PDO.h](#)

5.96 Pmap24 Class Reference

This is a [PDO](#) variable mapping class that extends the virtual [Pmap](#) class to handle 24-bit integers.

Inheritance diagram for Pmap24:

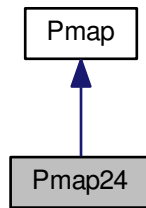

Collaboration diagram for Pmap24:

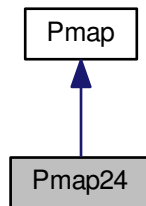

Public Member Functions

- [Pmap24](#) ()
Default constructor for a 24-bit mapping object.
- [Pmap24](#) (uint16 index, byte sub=0)
Create a new 24-bit mapping object.
- const [Error](#) * [Init](#) (uint16 index, byte sub=0)
Initialize a 24-bit mapping object.
- virtual void [Get](#) (byte *cptr)
Copy the current value of this variable into the passed character array.
- virtual void [Set](#) (byte *cptr)
Update the value of this variable based on the data passed in a character array.
- virtual [int32](#) [Read](#) (void)
Read the current value of this variable.
- virtual void [Write](#) (int32 d)
Write a new value to this variable.

Additional Inherited Members

5.96.1 Detailed Description

This is a [PDO](#) variable mapping class that extends the virtual [Pmap](#) class to handle 24-bit integers.

5.96.2 Constructor & Destructor Documentation

5.96.2.1 `Pmap24 (uint16 index, byte sub = 0) [inline]`

Create a new 24-bit mapping object.

Parameters

<i>index</i>	Object index associated with this variable
<i>sub</i>	Object sub-index (defaults to 0)

5.96.3 Member Function Documentation

5.96.3.1 `virtual void Get (byte * cptr) [inline],[virtual]`

Copy the current value of this variable into the passed character array.

This function is called when a receive [PDO](#) is about to be transmitted to a node.

Parameters

<i>cptr</i>	A character pointer that references a char array of at least 4 bytes. The current value of this variable will be copied there.
-------------	--

Reimplemented from [Pmap](#).

5.96.3.2 `const Error* Init (uint16 index, byte sub = 0) [inline]`

Initialize a 24-bit mapping object.

Parameters

<i>index</i>	Object index associated with this variable
<i>sub</i>	Object sub-index (defaults to 0)

Returns

An error object

5.96.3.3 `virtual int32 Read (void) [inline],[virtual]`

Read the current value of this variable.

Returns

The current value of this variable.

5.96.3.4 `virtual void Set (byte * cptr) [inline],[virtual]`

Update the value of this variable based on the data passed in a character array.

This function is called when a transmit PDO that this variable is mapped to is received.

Parameters

<i>cptr</i>	A character pointer that references a char array of at least 4 bytes. The value of this variable will be updated with the data passed in this array.
-------------	--

Reimplemented from [Pmap](#).

5.96.3.5 `virtual void Write (int32 d) [inline],[virtual]`

Write a new value to this variable.

Parameters

<i>d</i>	The new value to write.
----------	-------------------------

The documentation for this class was generated from the following file:

- [CML_PDO.h](#)

5.97 Pmap32 Class Reference

This is a PDO variable mapping class that extends the virtual [Pmap](#) class to handle 32-bit integers.

Inheritance diagram for Pmap32:

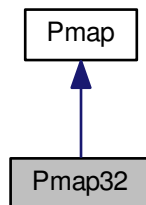

Collaboration diagram for Pmap32:

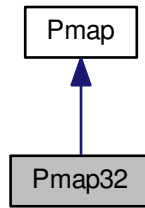

Public Member Functions

- [Pmap32](#) ()
Default constructor for a 32-bit mapping object.
- [Pmap32](#) (uint16 index, byte sub=0)
Create a new 32-bit mapping object.
- const [Error](#) * [Init](#) (uint16 index, byte sub=0)
Initialize a 32-bit mapping object.
- virtual void [Get](#) (byte *cptr)
Copy the current value of this variable into the passed character array.
- virtual void [Set](#) (byte *cptr)
Update the value of this variable based on the data passed in a character array.
- virtual [int32](#) [Read](#) (void)
Read the current value of this variable.
- virtual void [Write](#) (int32 d)
Write a new value to this variable.

Additional Inherited Members

5.97.1 Detailed Description

This is a [PDO](#) variable mapping class that extends the virtual [Pmap](#) class to handle 32-bit integers.

5.97.2 Constructor & Destructor Documentation

5.97.2.1 [Pmap32](#) (uint16 index, byte sub = 0) [inline]

Create a new 32-bit mapping object.

Parameters

<i>index</i>	Object index associated with this variable
<i>sub</i>	Object sub-index (defaults to 0)

5.97.3 Member Function Documentation

5.97.3.1 virtual void Get (byte * *cptr*) [inline],[virtual]

Copy the current value of this variable into the passed character array.

This function is called when a receive PDO is about to be transmitted to a node.

Parameters

<i>cptr</i>	A character pointer that references a char array of at least 4 bytes. The current value of this variable will be copied there.
-------------	--

Reimplemented from [Pmap](#).

5.97.3.2 const Error* Init (uint16 *index*, byte *sub* = 0) [inline]

Initialize a 32-bit mapping object.

Parameters

<i>index</i>	Object index associated with this variable
<i>sub</i>	Object sub-index (defaults to 0)

Returns

An error object

5.97.3.3 virtual int32 Read (void) [inline],[virtual]

Read the current value of this variable.

Returns

The current value of this variable.

5.97.3.4 virtual void Set (byte * *cptr*) [inline],[virtual]

Update the value of this variable based on the data passed in a character array.

This function is called when a transmit PDO that this variable is mapped to is received.

Parameters

<i>cptr</i>	A character pointer that references a char array of at least 4 bytes. The value of this variable will be updated with the data passed in this array.
-------------	--

Reimplemented from [Pmap](#).

5.97.3.5 `virtual void Write (int32 d) [inline],[virtual]`

Write a new value to this variable.

Parameters

<i>d</i>	The new value to write.
----------	-------------------------

The documentation for this class was generated from the following file:

- [CML_PDO.h](#)

5.98 Pmap8 Class Reference

This is a [PDO](#) variable mapping class that extends the virtual [Pmap](#) class to handle 8-bit integers.

Inheritance diagram for Pmap8:

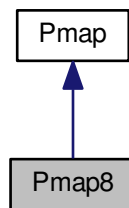

Collaboration diagram for Pmap8:

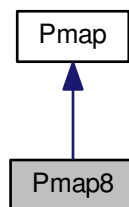

Public Member Functions

- [Pmap8 \(\)](#)
Default constructor for a 8-bit mapping object.
- [Pmap8 \(uint16 index, byte sub=0\)](#)
Create a new 8-bit mapping object.

- const `Error * Init (uint16 index, byte sub=0)`
Initialize a 8-bit mapping object.
- virtual void `Get (byte *cptr)`
Copy the current value of this variable into the passed character array.
- virtual void `Set (byte *cptr)`
Update the value of this variable based on the data passed in a character array.
- virtual `byte Read (void)`
Read the current value of this variable.
- virtual void `Write (byte d)`
Write a new value to this variable.

Additional Inherited Members

5.98.1 Detailed Description

This is a [PDO](#) variable mapping class that extends the virtual [Pmap](#) class to handle 8-bit integers.

5.98.2 Constructor & Destructor Documentation

5.98.2.1 `Pmap8 (uint16 index, byte sub = 0) [inline]`

Create a new 8-bit mapping object.

Parameters

<i>index</i>	Object index associated with this variable
<i>sub</i>	Object sub-index (defaults to 0)

5.98.3 Member Function Documentation

5.98.3.1 `virtual void Get (byte * cptr) [inline],[virtual]`

Copy the current value of this variable into the passed character array.

This function is called when a receive [PDO](#) is about to be transmitted to a node.

Parameters

<i>cptr</i>	A character pointer that references a char array of at least 1 bytes. The current value of this variable will be copied there.
-------------	--

Reimplemented from [Pmap](#).

5.98.3.2 `const Error* Init (uint16 index, byte sub = 0) [inline]`

Initialize a 8-bit mapping object.

Parameters

<i>index</i>	Object index associated with this variable
<i>sub</i>	Object sub-index (defaults to 0)

Returns

An error object

5.98.3.3 virtual byte Read (void) [inline],[virtual]

Read the current value of this variable.

Returns

The current value of this variable.

5.98.3.4 virtual void Set (byte * cptr) [inline],[virtual]

Update the value of this variable based on the data passed in a character array.

This function is called when a transmit PDO that this variable is mapped to is received.

Parameters

<i>cptr</i>	A character pointer that references a char array of at least 1 bytes. The value of this variable will be updated with the data passed in this array.
-------------	--

Reimplemented from [Pmap](#).

5.98.3.5 virtual void Write (byte d) [inline],[virtual]

Write a new value to this variable.

Parameters

<i>d</i>	The new value to write.
----------	-------------------------

The documentation for this class was generated from the following file:

- [CML_PDO.h](#)

5.99 PmapRaw Class Reference

This is the most generic PDO variable mapping class.

Inheritance diagram for PmapRaw:

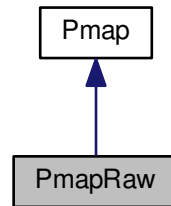

Collaboration diagram for PmapRaw:

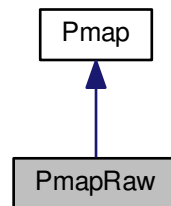

Public Member Functions

- [PmapRaw](#) ()
Default constructor.
- [PmapRaw](#) (uint16 index, byte sub, byte bits)
Create a new mapping object.
- virtual void [Get](#) (byte *cptr)
Copy the current value of this variable into the passed character array.
- virtual void [Set](#) (byte *cptr)
Update the value of this variable based on the data passed in a character array.

Additional Inherited Members

5.99.1 Detailed Description

This is the most generic [PDO](#) variable mapping class.

It doesn't do any special formatting, just holds up to 8 bytes of raw data.

5.99.2 Constructor & Destructor Documentation

5.99.2.1 PmapRaw (uint16 *index*, byte *sub*, byte *bits*) [inline]

Create a new mapping object.

Parameters

<i>index</i>	Object index associated with this variable
<i>sub</i>	Object sub-index
<i>bits</i>	The size of the variable in bits

5.99.3 Member Function Documentation

5.99.3.1 virtual void Get (byte * *cptr*) [inline],[virtual]

Copy the current value of this variable into the passed character array.

This function is called when a receive PDO is about to be transmitted to a node.

Parameters

<i>cptr</i>	A character pointer that references a char array large enough to hold this objects data.
-------------	--

Reimplemented from [Pmap](#).

5.99.3.2 virtual void Set (byte * *cptr*) [inline],[virtual]

Update the value of this variable based on the data passed in a character array.

This function is called when a transmit PDO that this variable is mapped to is received.

Parameters

<i>cptr</i>	A pointer to the received data.
-------------	---------------------------------

Reimplemented from [Pmap](#).

The documentation for this class was generated from the following file:

- [CML_PDO.h](#)

5.100 Point< N > Class Template Reference

Template used for N dimensional objects.

Inheritance diagram for Point< N >:

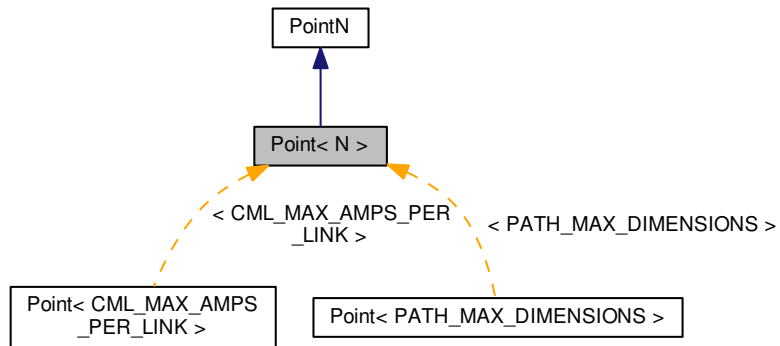

Collaboration diagram for Point< N >:

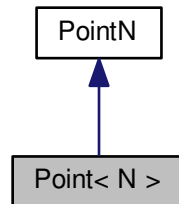

Public Member Functions

- int `getDim` (void) const
Get the number of dimensions of this point.
- int `getMax` (void) const
Get the max dimensions that this point can handle.
- void `setDim` (int d)
Set the number of dimensions of this point.

5.100.1 Detailed Description

```
template<int N>class Point< N >
```

Template used for N dimensional objects.

This template may be used to generate point objects for some fixed number of dimensions.

5.100.2 Member Function Documentation

5.100.2.1 `int getDim (void) const [inline],[virtual]`

Get the number of dimensions of this point.

Returns

The point dimension

Implements [PointN](#).

5.100.2.2 `int getMax (void) const [inline],[virtual]`

Get the max dimensions that this point can handle.

Returns

The max value.

Implements [PointN](#).

5.100.2.3 `void setDim (int d) [inline],[virtual]`

Set the number of dimensions of this point.

Parameters

<code>d</code>	The new point dimension
----------------	-------------------------

Implements [PointN](#).

The documentation for this class was generated from the following file:

- [CML_Geometry.h](#)

5.101 PointN Class Reference

An N axis point.

Inheritance diagram for PointN:

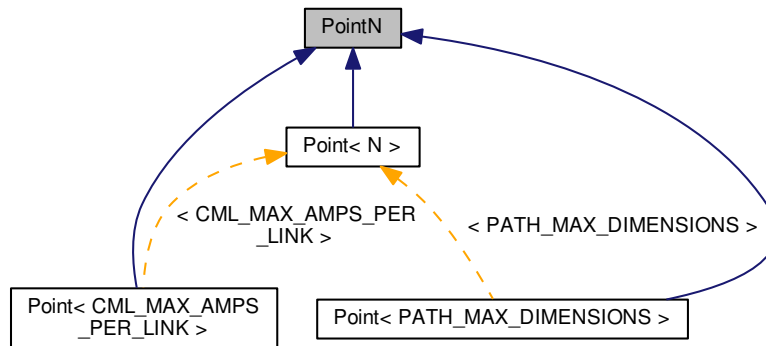

Public Member Functions

- virtual `~PointN ()`
Virtual destructor.
- virtual `int getDim (void) const =0`
Get the number of dimensions of this point.
- virtual `void setDim (int d)=0`
Set the number of dimensions of this point.
- virtual `int getMax (void) const =0`
Get the max dimensions that this point can handle.

5.101.1 Detailed Description

An N axis point.

This point specifies a position in N dimensions.

This is a pure virtual base class of the more specific [Point](#) classes.

5.101.2 Member Function Documentation

5.101.2.1 `virtual int getDim (void) const [pure virtual]`

Get the number of dimensions of this point.

Returns

The point dimension

Implemented in [Point< N >](#), [Point< CML_MAX_AMPS_PER_LINK >](#), and [Point< PATH_MAX_DIMENSIONS >](#).

5.101.2.2 `virtual int getMax (void) const [pure virtual]`

Get the max dimensions that this point can handle.

Returns

The max value.

Implemented in [Point< N >](#), [Point< CML_MAX_AMPS_PER_LINK >](#), and [Point< PATH_MAX_DIMENSIONS >](#).

5.101.2.3 `virtual void setDim (int d) [pure virtual]`

Set the number of dimensions of this point.

Parameters

<i>d</i>	The new point dimension
----------	-------------------------

Implemented in [Point< N >](#), [Point< CML_MAX_AMPS_PER_LINK >](#), and [Point< PATH_MAX_DIMENSIONS >](#).

The documentation for this class was generated from the following files:

- [CML_Geometry.h](#)
- [Geometry.cpp](#)

5.102 PosLoopConfig Struct Reference

This structure holds the position loop configuration parameters specific to the Copley amplifier.

Public Member Functions

- [PosLoopConfig](#) (void)
Default constructor.

Public Attributes

- [int16 kp](#)
Proportional gain.
- [int16 kvff](#)
Velocity feed forward.
- [int16 kaff](#)
Acceleration feed forward.
- [int16 ki](#)
Integral gain.
- [int16 kd](#)
Derivative gain.
- [int16 scale](#)
Scaling factor.
- [int16 xKd](#)

cross coupling derivative gain

- [int16 xKi](#)

cross coupling integral gain

- [int16 xKp](#)

cross coupling proportional gain

- [int16 kiDrain](#)

Position loop drain value for integral sum. Set to 0 to disable.

5.102.1 Detailed Description

This structure holds the position loop configuration parameters specific to the Copley amplifier.

The position loop is one of three servo control loops used by the amplifier to control a motor. The configuration parameters used by this control loop allow the servo performance to be 'tuned' for various motors and loads.

The amplifier member functions [Amp::GetPosLoopConfig](#) and [Amp::SetPosLoopConfig](#) are used to read and write this data to the amplifier.

5.102.2 Constructor & Destructor Documentation

5.102.2.1 PosLoopConfig (void) [inline]

Default constructor.

Simply initializes all servo parameters to zero.

5.102.3 Member Data Documentation

5.102.3.1 int16 scale

Scaling factor.

This is a multiplier that is applied to the output of the position loop. It's scaled up by 100, so setting the scaling factor to 1234 would multiply the output of the loop by 12.34. This parameter was added in firmware version 3.30. For any earlier version it will default to 100 (scale by 1.0).

The documentation for this struct was generated from the following file:

- [CML_AmpStruct.h](#)

5.103 ProfileConfig Struct Reference

Amplifier profile parameters.

Public Member Functions

- [ProfileConfig](#) (void)

Default constructor. Simply set all parameters to zero.

Public Attributes

- [PROFILE_TYPE](#) type
Type of profile to be used.
- [uunit pos](#)
For absolute moves this is an absolute position, for relative moves it's a distance to move.
- [uunit vel](#)
Velocity limit for move.
- [uunit acc](#)
Acceleration limit for move.
- [uunit dec](#)
Deceleration limit for move.
- [uunit abort](#)
Acceleration value to use when aborting a running trajectory.
- [uunit jrk](#)
Jerk limit for move.

5.103.1 Detailed Description

Amplifier profile parameters.

This structure holds all the parameters related to point-to-point profile moves.

5.103.2 Member Data Documentation

5.103.2.1 [uunit abort](#)

Acceleration value to use when aborting a running trajectory.

This is the same as the 'quick stop' deceleration.

5.103.2.2 [uunit pos](#)

For absolute moves this is an absolute position, for relative moves it's a distance to move.

The documentation for this struct was generated from the following file:

- [CML_AmpStruct.h](#)

5.104 ProfileConfigScurve Struct Reference

S-curve profile parameters.

Public Member Functions

- [ProfileConfigScurve](#) (void)
Default constructor. Simply set all parameters to zero.

Public Attributes

- [uunit pos](#)

For absolute moves this is an absolute position, for relative moves it's a distance to move.

- [uunit vel](#)

Velocity limit for move.

- [uunit acc](#)

Acceleration limit for move.

- [uunit jrk](#)

Jerk limit for move.

5.104.1 Detailed Description

S-curve profile parameters.

This structure holds all the parameters necessary to perform a s-curve (jerk limited) profile move.

5.104.2 Member Data Documentation

5.104.2.1 [uunit acc](#)

Acceleration limit for move.

This parameter is specified in "user units". See [Amp::SetCountsPerUnit](#) for details.

5.104.2.2 [uunit jrk](#)

Jerk limit for move.

This parameter is specified in "user units". See [Amp::SetCountsPerUnit](#) for details.

5.104.2.3 [uunit pos](#)

For absolute moves this is an absolute position, for relative moves it's a distance to move.

This parameter is specified in "user units". See [Amp::SetCountsPerUnit](#) for details.

5.104.2.4 [uunit vel](#)

Velocity limit for move.

This parameter is specified in "user units". See [Amp::SetCountsPerUnit](#) for details.

The documentation for this struct was generated from the following file:

- [CML_Amp.h](#)

5.105 ProfileConfigTrap Struct Reference

Trapezoidal profile parameters.

Public Member Functions

- [ProfileConfigTrap](#) (void)

Default constructor. Simply set all parameters to zero.

Public Attributes

- [uunit pos](#)

For absolute moves this is an absolute position, for relative moves it's a distance to move.

- [uunit vel](#)

Velocity limit for move.

- [uunit acc](#)

Acceleration limit for move.

- [uunit dec](#)

Deceleration limit for move.

5.105.1 Detailed Description

Trapezoidal profile parameters.

This structure holds all the parameters necessary to perform a trapezoidal profile move.

5.105.2 Member Data Documentation

5.105.2.1 uunit acc

Acceleration limit for move.

This parameter is specified in "user units". See [Amp::SetCountsPerUnit](#) for details.

5.105.2.2 uunit dec

Deceleration limit for move.

Note that if this parameter is not set, then the acceleration value will be used for deceleration.

This parameter is specified in "user units". See [Amp::SetCountsPerUnit](#) for details.

5.105.2.3 uunit pos

For absolute moves this is an absolute position, for relative moves it's a distance to move.

This parameter is specified in "user units". See [Amp::SetCountsPerUnit](#) for details.

5.105.2.4 uunit vel

Velocity limit for move.

This parameter is specified in "user units". See [Amp::SetCountsPerUnit](#) for details.

The documentation for this struct was generated from the following file:

- [CML_Amp.h](#)

5.106 ProfileConfigVel Struct Reference

Velocity profile parameters.

Public Member Functions

- [ProfileConfigVel](#) (void)
Default constructor. Simply set all parameters to zero.

Public Attributes

- [uunit dir](#)
Direction of motion.
- [uunit vel](#)
Velocity limit for move.
- [uunit acc](#)
Acceleration limit for move.
- [uunit dec](#)
Deceleration limit for move.

5.106.1 Detailed Description

Velocity profile parameters.

This structure holds all the parameters necessary to perform a velocity profile move.

5.106.2 Member Data Documentation

5.106.2.1 uunit acc

Acceleration limit for move.

This parameter is specified in "user units". See [Amp::SetCountsPerUnit](#) for details.

5.106.2.2 uunit dec

Deceleration limit for move.

This parameter is specified in "user units". See [Amp::SetCountsPerUnit](#) for details.

5.106.2.3 uunit dir

Direction of motion.

If ≥ 0 , then move in the positive direction If < 0 , then move in the negative direction.

5.106.2.4 uunit vel

Velocity limit for move.

This parameter is specified in "user units". See [Amp::SetCountsPerUnit](#) for details.

The documentation for this struct was generated from the following file:

- [CML_Amp.h](#)

5.107 PvtSegCache Class Reference

PVT trajectory segment cache object.

Public Member Functions

- [PvtSegCache](#) ()
Default constructor. Clears the cache.
- void [Clear](#) ()
Clear the cache.
- void [AddSegment](#) (uint8 *seg, uint16 id, uunit p)
Add the passed segment to the cache.
- bool [GetSegment](#) (uint8 *seg, uint16 id)
Get the specified segment from the cache.
- bool [GetPosition](#) (uunit *p, uint16 id)
Get the position corresponding to the specified segment from the cache.

5.107.1 Detailed Description

PVT trajectory segment cache object.

This is used internally by the [Amp](#) object to keep track of PVT segments recently sent. It allows the amp object to recover if a segment is lost in transit by resending the missing segments.

5.107.2 Member Function Documentation

5.107.2.1 void AddSegment (uint8 * seg, uint16 id, uunit p)

Add the passed segment to the cache.

Segments must be passed in order and with no gaps between ID numbers. If this segment doesn't follow those rules then the cache will be cleared before the segment is added.

Parameters

<i>seg</i>	Points to an array of 8 bytes which make up the segment to be added. The segment data is copied into the cache. No copy of the pointer is kept locally.
------------	---

<i>id</i>	The ID number of the passed segment.
<i>p</i>	The position corresponding to this segment.

5.107.2.2 bool GetPosition (uunit * p, uint16 id)

Get the position corresponding to the specified segment from the cache.

If the requested position is available, it will be copied to the passed pointer.

Parameters

<i>p</i>	A pointer to where the position information will be copied.
<i>id</i>	The ID number of the segment being requested

Returns

true on success, false if the requested segment isn't available.

5.107.2.3 bool GetSegment (uint8 * seg, uint16 id)

Get the specified segment from the cache.

If the requested segment is available, it's contents will be copied to the passed pointer.

Parameters

<i>seg</i>	A pointer to an array of 8 bytes where the segment data will be copied on success.
<i>id</i>	The ID number of the segment being requested

Returns

true on success, false if the requested segment isn't available.

The documentation for this class was generated from the following files:

- [CML_Amp.h](#)
- [AmpPVT.cpp](#)

5.108 PwmInConfig Struct Reference

PWM or Pulse/Direction input configuration.

Public Member Functions

- [PwmInConfig](#) (void)

Default constructor. Simply sets all members to zero.

Public Attributes

- [int16 cfg](#)
PWM input pin configuration.
- [int32 uvCfg](#)
PWM input UV configuration.
- [int32 scale](#)
Scaling factor.
- [int16 freq](#)
PWM input frequency.

5.108.1 Detailed Description

PWM or Pulse/Direction input configuration.

These parameters are used when the amplifier is being controlled through it's PWM inputs (current or velocity mode), or pulse/direction input pins (position mode). These parameters have no effect when running in standard CANopen modes of operation.

5.108.2 Member Data Documentation

5.108.2.1 [int16 cfg](#)

PWM input pin configuration.

See amplifier documentation for detailed information.

5.108.2.2 [int16 freq](#)

PWM input frequency.

This parameter is only used when running in UV current mode. For other PWM or step/dir input modes the PWM frequency is automatically calculated by the amplifier and this parameter is ignored. The frequency is set 10 Hz units. For example, setting this parameter to 100 indicates that the PWM input frequency is 1kHz.

5.108.2.3 [int32 scale](#)

Scaling factor.

Units are dependent on the mode of operation: 0.01 [Amp](#) when driving current. 0.1 Encoder counts/second when driving velocity Encoder counts (upper 16 bits) / pulses (lower 16 bits) ratio for position mode.

5.108.2.4 [int32 uvCfg](#)

PWM input UV configuration.

Used to configure the drive when running in UV mode (desired state 5). See documentation

The documentation for this struct was generated from the following file:

- [CML_AmpStruct.h](#)

5.109 Receiver Class Reference

CANopen receiver object.

Inheritance diagram for Receiver:

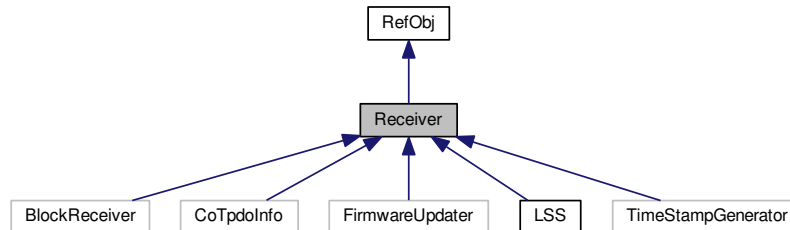

Collaboration diagram for Receiver:

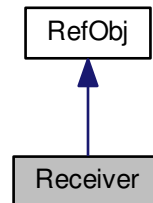

Public Member Functions

- [Receiver](#) ()
Default constructor for a network receiver object.
- virtual [~Receiver](#) ()
Destructor for network receiver objects.
- virtual int [NewFrame](#) ([CanFrame](#) &frame)
Process a new received CAN bus frame.

Additional Inherited Members

5.109.1 Detailed Description

CANopen receiver object.

This class allows the programmer to create routines that are run whenever a CAN frame with a specific ID is received.

To run code when a message is received, create a new class that extends [Receiver](#). The `Receiver::Init()` function should be called with the CAN message ID of the frames to be received. Whenever this new class is `Enabled()`, the member function `NewFrame()` will be called once for every frame received with a matching ID.

5.109.2 Constructor & Destructor Documentation

5.109.2.1 `~Receiver () [virtual]`

Destructor for network receiver objects.

This destructor ensures that the receiver is disabled before it is destroyed.

5.109.3 Member Function Documentation

5.109.3.1 `int NewFrame (CanFrame & frame) [virtual]`

Process a new received CAN bus frame.

This virtual function is called by the CANopen read thread every time a CAN frame is received over the network with an ID matching the receivers ID if the receiver is enabled.

Note that this function is called from the CANopen receive thread. No other receive frames will be processed until this function returns.

Also note that the map object used to associate message IDs with receive objects is locked when this function is called. The locking is required to prevent a race condition that could occur when a receive object is disabled and its memory is deallocated. Since the map is locked, it's illegal to `Enable()` or `Disable()` any receive object from within this function.

Parameters

<i>frame</i>	The CAN frame to be processed. Note that the memory holding the frame structure may be reused after the call returns. If the frame contents are to be used after the return the a copy of the frame should be made.
--------------	---

Returns

non-zero if the frame was handled, zero if the frame type was unknown.

Reimplemented in [LSS](#).

The documentation for this class was generated from the following files:

- [CML_CanOpen.h](#)
- [CanOpen.cpp](#)

5.110 RefObj Class Reference

This class is used to track object references in the CML library.

Inheritance diagram for RefObj:

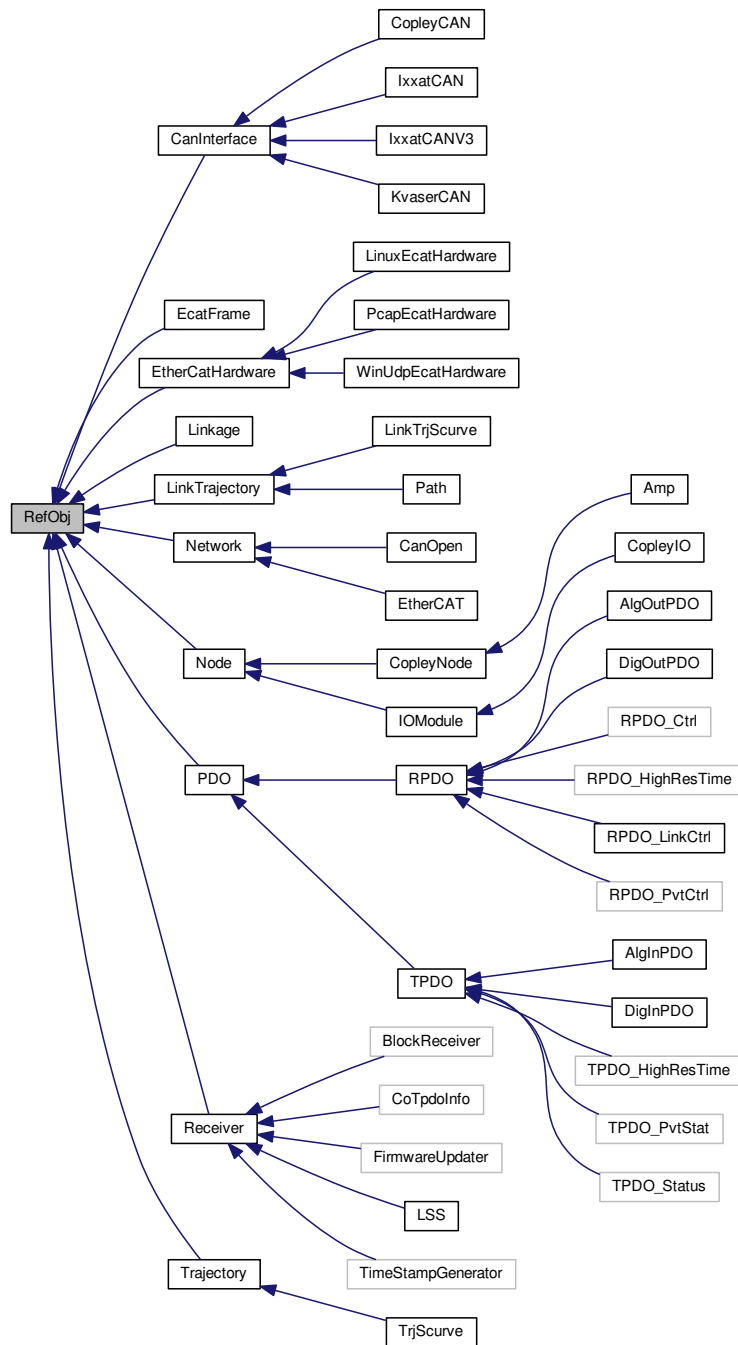

Public Member Functions

- [RefObj](#) (const char *name=0)

Default constructor for a reference object.

- virtual `~RefObj ()`

Reference object destructor.

- void `SetRefName (const char *name)`

Assign a name to this reference.

- `uint32 GrabRef (void)`

Grab a reference to this object.

- void `setAutoDelete (bool autoDeleteEna)`

This function is used to enable or disable the autodelete function for a reference object.

- void `UnlockRef (void)`

Unlock an object that was previously locked using `RefObj::Lock`.

Static Public Member Functions

- static void `ReleaseRef (uint32 id)`

Release the local reference to this object.

- static `RefObj * LockRef (uint32 id)`

Find the object associated with the passed reference number and lock it to prevent the object from being destroyed while I'm accessing it.

- static void `LogRefs (void)`

This function is provided for debugging.

Protected Member Functions

- void `KillRef (void)`

Destroy this reference.

5.110.1 Detailed Description

This class is used to track object references in the CML library.

Most CML objects use the `RefObj` class as a base class. This class assigns an integer ID to the object which can be used as a safer alternative to keeping a pointer to the object.

5.110.2 Constructor & Destructor Documentation

5.110.2.1 `RefObj (const char * name = 0)`

Default constructor for a reference object.

This allocates a reference ID which will be associated with this object for as long as any references to the object exist. This ID can be safely used to find a pointer to the object.

Parameters

<i>name</i>	An optional string that identifies the reference for debugging purposes. If a string is passed it should persist for the entire life of the reference object.
-------------	---

5.110.2.2 `~RefObj() [virtual]`

Reference object destructor.

If this object has been locked then this function won't return until the reference has been unlocked.

5.110.3 Member Function Documentation**5.110.3.1** `uint32 GrabRef(void)`

Grab a reference to this object.

This function increases the reference count associated with the object. The reference returned can be safely used to lock and unlock the associated object.

For each call to `GrabRef`, there should be a corresponding call to `RefObj::ReleaseRef` to release the reference when it's no longer needed.

Returns

The object reference, or 0 if it wasn't possible to grab a reference to the object.

5.110.3.2 `void KillRef(void) [protected]`

Destroy this reference.

This function should be called at the beginning of the destructor of any object that inherits from `RefObj`. It removes this reference from the system and delays until no other threads are actively using a pointer to the referenced object.

This should be the first thing done in a destructor of any class that inherits from a `RefObj`, even if it inherits indirectly from the reference. When `KillRef` is called, the reference class makes sure that no other thread is holding a lock on the class. This prevents accidental object deletion while an object is still in use by another thread.

5.110.3.3 `RefObj* LockRef(uint32 val) [static]`

Find the object associated with the passed reference number and lock it to prevent the object from being destroyed while I'm accessing it.

The lock should only be held for a short time because it can prevent other threads from deleting the object. Call `RefObj::Unlock` when finished accessing the object.

Parameters

<i>val</i>	The reference ID associated with the object
------------	---

Returns

A pointer to the referenced object if it still exists, or NULL if it's been destroyed.

5.110.3.4 `void LogRefs(void) [static]`

This function is provided for debugging.

It prints out information on all references that are currently held to the `cml.log` file

5.110.3.5 void ReleaseRef (uint32 val) [static]

Release the local reference to this object.

Parameters

<i>val</i>	The reference previously returned by a call to RefObj::GrabRef
------------	--

5.110.3.6 void setAutoDelete (bool *autoDeleteEna*)

This function is used to enable or disable the autodelete function for a reference object.

If automatic deletion is enabled, the object will be deleted automatically when its reference count indicates that there are no other objects in the system which are still holding a reference to it.

Obviously, this should only be enabled for objects that have been allocated from the heap using the new operator.

Parameters

<i>autoDeleteEna</i>	Boolean that if is true enabled the auto delete
----------------------	---

5.110.3.7 void SetRefName (const char * *name*)

Assign a name to this reference.

The name is used for debugging purposes.

Parameters

<i>name</i>	Pointer to the name. Note that a local copy of this pointer will be stored in the reference object.
-------------	---

The documentation for this class was generated from the following files:

- [CML_Reference.h](#)
- [Reference.cpp](#)

5.111 RefObjLocker< RefClass > Class Template Reference

This is a utility class that locks a reference in its constructor, and unlocks it in its destructor.

Public Member Functions

- [RefObjLocker](#) (uint32 r)
Lock the passed reference.
- [~RefObjLocker](#) ()
Unlock the reference.
- RefClass * [operator->](#) (void)
Return a pointer to the referenced object.
- RefClass & [operator*](#) (void)
Return a C++ reference to the referenced object.

5.111.1 Detailed Description

```
template<class RefClass>class RefObjLocker< RefClass >
```

This is a utility class that locks a reference in it's constructor, and unlocks it in it's destructor.

It can be used to ensure that a reference is properly unlocked when a function returns.

5.111.2 Constructor & Destructor Documentation

5.111.2.1 RefObjLocker (uint32 r) [inline]

Lock the passed reference.

Parameters

<i>r</i>	The reference to lock
----------	-----------------------

5.111.3 Member Function Documentation

5.111.3.1 RefClass& operator*(void) [inline]

Return a C++ reference to the referenced object.

Returns

a C++ reference to the locked reference object

5.111.3.2 RefClass* operator->(void) [inline]

Return a pointer to the referenced object.

Returns

a pointer to the locked reference object

The documentation for this class was generated from the following file:

- [CML_Reference.h](#)

5.112 RegenConfig Struct Reference

Configuration structure used to set up the amplifier regeneration resister.

Public Member Functions

- [RegenConfig](#) (void)

Default constructor.

Public Attributes

- char `model` [COPLEY_MAX_STRING]
Model number / name string for regen resister connected to the amplifier.
- `uint16 resistance`
Regen resister resistance (100 milliohm units)
- `uint16 contPower`
Continuous power limit for regen resister (Watts).
- `uint16 peakPower`
Peak power limit for resister (Watts).
- `uint16 peakTime`
Peak time limit (milliseconds).
- `uint16 vOn`
Regen resister turn on voltage (100 millivolt units).
- `uint16 vOff`
Regen resister turn off voltage (100 millivolt units).

5.112.1 Detailed Description

Configuration structure used to set up the amplifier regeneration resister.

The regen resister is not available on all amplifier models (currently only on the Xenus offline amplifier).

These settings may be up/download from the amplifier using the functions [Amp::SetRegenConfig](#) and [Amp::GetRegen-Config](#).

5.112.2 Constructor & Destructor Documentation

5.112.2.1 `RegenConfig(void)` [`inline`]

Default constructor.

Initializes all structure elements to zero.

5.112.3 Member Data Documentation

5.112.3.1 `uint16 contPower`

Continuous power limit for regen resister (Watts).

This is the amount of power that the resister is able to disapate continuously

5.112.3.2 `char model[COPLEY_MAX_STRING]`

Model number / name string for regen resister connected to the amplifier.

5.112.3.3 `uint16 peakPower`

Peak power limit for resister (Watts).

This is the maximum amount of power that the resister is able to dissapate for a limited amount of time.

5.112.3.4 uint16 peakTime

Peak time limit (milliseconds).

This is the amount of time that the regen resistor is able to dissipate peak power before it needs to be folded back to the continuous power limit.

5.112.3.5 uint16 vOff

Regen resistor turn off voltage (100 millivolt units).

When the bus voltage drops below this value, the regen resistor will be disabled.

5.112.3.6 uint16 vOn

Regen resistor turn on voltage (100 millivolt units).

When the bus voltage rises above this value the regen resistor will be enabled.

The documentation for this struct was generated from the following file:

- [CML_AmpStruct.h](#)

5.113 RPDO Class Reference

Receive [PDO](#) (received by node, transmitted by this software).

Inheritance diagram for RPDO:

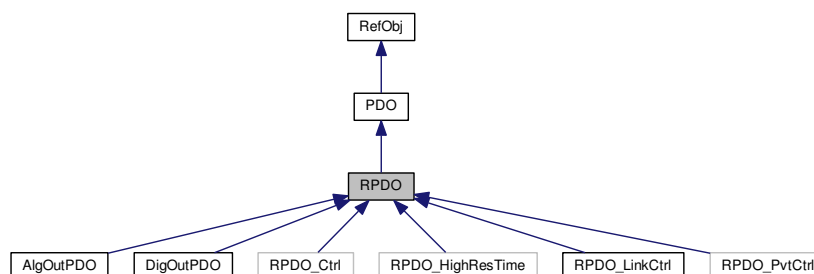

Collaboration diagram for RPDO:

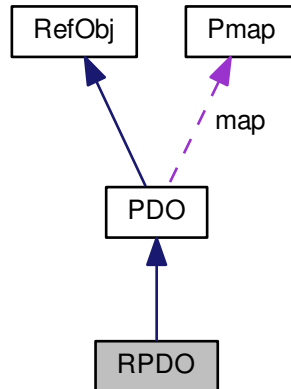

Public Member Functions

- [RPDO](#) ()
Default constructor.
- bool [IsTxPDO](#) (void)
Always return false for transmit [PDO](#) objects.
- [RPDO](#) (uint32 cobID)
Construct the [PDO](#) object and initialize it.
- virtual [~RPDO](#) ()
Virtual destructor.
- virtual const [Error](#) * [Init](#) (uint32 cobID)
Initialize the [PDO](#) object.
- virtual const [Error](#) * [Transmit](#) ([Network](#) &n)
Transmit this [PDO](#) over the passed network.
- int [LoadData](#) (uint8 *buff, int max)
Load the data from this [PDO](#) into the passed buffer.

Additional Inherited Members

5.113.1 Detailed Description

Receive [PDO](#) (received by node, transmitted by this software).

5.113.2 Constructor & Destructor Documentation

5.113.2.1 RPDO (uint32 cobID) [inline]

Construct the [PDO](#) object and initialize it.

Parameters

<i>cobID</i>	The CAN message ID associated with this PDO
--------------	---

5.113.3 Member Function Documentation

5.113.3.1 virtual const Error* Init (uint32 *cobID*) [inline],[virtual]

Initialize the [PDO](#) object.

Parameters

<i>cobID</i>	The CAN message ID associated with this PDO
--------------	---

Returns

A pointer to an error object, or NULL on success

5.113.3.2 int LoadData (uint8 * *buff*, int *max*)

Load the data from this [PDO](#) into the passed buffer.

Parameters

<i>buff</i>	Buffer where data will be loaded
<i>max</i>	The maximum number of bytes to load.

Returns

The actual number of bytes loaded.

The documentation for this class was generated from the following files:

- [CML_PDO.h](#)
- [PDO.cpp](#)

5.114 RPDO_LinkCtrl Class Reference

Receive [PDO](#) used to update the control word of all amplifiers in the linkage.

Inheritance diagram for RPDO_LinkCtrl:

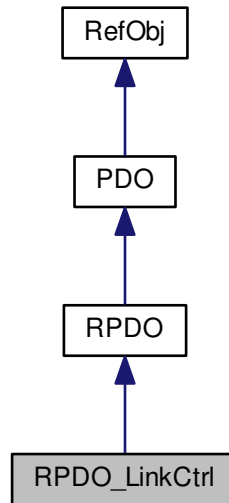

Collaboration diagram for RPDO_LinkCtrl:

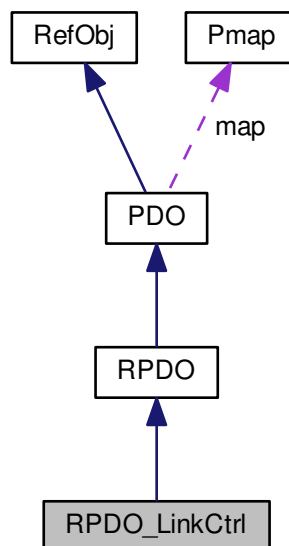

Public Member Functions

- [RPDO_LinkCtrl](#) (class [Linkage](#) &l)
Default constructor for this [PDO](#).
- const [Error](#) * [Init](#) (void)
Initialize the receive [PDO](#) used to control words to each amplifier held by a linkage.
- const [Error](#) * [Transmit](#) (uint16 c)
Transmit a control word using this [PDO](#).

Additional Inherited Members

5.114.1 Detailed Description

Receive [PDO](#) used to update the control word of all amplifiers in the linkage.

This object is intended for internal use only.

5.114.2 Member Function Documentation

5.114.2.1 const [Error](#) * [Init](#) (void)

Initialize the receive [PDO](#) used to control words to each amplifier held by a linkage.

The COB ID used for this [PDO](#) is the standard ID used for [RPDO](#) 1 of the first axis.

Returns

An error object pointer on failure, NULL on success

5.114.2.2 const [Error](#) * [Transmit](#) (uint16 c)

Transmit a control word using this [PDO](#).

Parameters

<i>c</i>	Value of the control word to send.
----------	------------------------------------

Returns

A pointer to an error object, or NULL on success.

The documentation for this class was generated from the following files:

- [CML_Linkage.h](#)
- [Linkage.cpp](#)

5.115 ScurveError Class Reference

This class represents error conditions that can occur in the [TrjScurve](#) class.

Inheritance diagram for ScurveError:

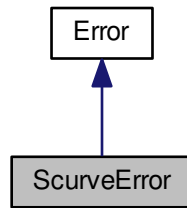

Collaboration diagram for ScurveError:

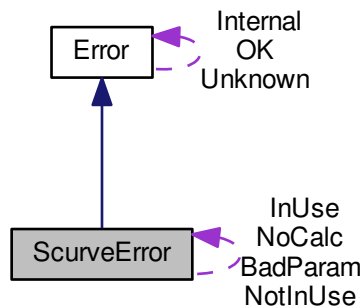

Static Public Attributes

- static const [ScurveError BadParam](#)
Illegal input parameter.
- static const [ScurveError NoCalc](#)
Trajectory has not been calculated.
- static const [ScurveError InUse](#)
Trajectory is currently in use.
- static const [ScurveError NotInUse](#)
Trajectory has not been started.

Protected Member Functions

- [ScurveError](#) (uint16 id, const char *desc)

Standard protected constructor.

Additional Inherited Members

5.115.1 Detailed Description

This class represents error conditions that can occur in the [TrjScurve](#) class.

The documentation for this class was generated from the following file:

- [CML_TrjScurve.h](#)

5.116 SDO Class Reference

CANopen Service Data Object ([SDO](#)).

Public Member Functions

- [SDO](#) ()
Default SDO object constructor.
- const [Error](#) * [Init](#) ([Node](#) *node, Timeout to=2000)
Initialize a CANopen Service Data Object (SDO).
- const [Error](#) * [Download](#) (int16 index, int16 sub, int32 size, [byte](#) *data)
Download data using this SDO.
- const [Error](#) * [Upload](#) (int16 index, int16 sub, int32 &size, [byte](#) *data)
Upload data using this SDO.
- const [Error](#) * [BlockDnld](#) (int16 index, int16 sub, int32 size, [byte](#) *data)
Download data using this SDO.
- const [Error](#) * [BlockUpld](#) (int16 index, int16 sub, int32 &size, [byte](#) *data)
Upload data using this SDO.
- const [Error](#) * [Dnld32](#) (int16 index, int16 sub, uint32 data)
Download a 32-bit value using this SDO.
- const [Error](#) * [Upld32](#) (int16 index, int16 sub, uint32 &data)
Upload a 32-bit value using this SDO.
- const [Error](#) * [Dnld16](#) (int16 index, int16 sub, uint16 data)
Download a 16-bit value using this SDO.
- const [Error](#) * [Upld16](#) (int16 index, int16 sub, uint16 &data)
Upload a 16-bit value using this SDO.
- const [Error](#) * [Dnld8](#) (int16 index, int16 sub, uint8 data)
Download a 8-bit value using this SDO.
- const [Error](#) * [Upld8](#) (int16 index, int16 sub, uint8 &data)
Upload a 8-bit value using this SDO.
- const [Error](#) * [DnldString](#) (int16 index, int16 sub, [char](#) *data)
Download a visible string type using the SDO.
- const [Error](#) * [UpldString](#) (int16 index, int16 sub, int32 &len, [char](#) *data)
Upload a visible string type from the SDO.
- const [Error](#) * [Download](#) (int16 index, int16 sub, int32 size, [char](#) *data)

- Download data using this [SDO](#).*

 - const [Error](#) * [Upload](#) (int16 index, int16 sub, int32 &size, char *data)

Upload data using this [SDO](#).

 - const [Error](#) * [Dnld32](#) (int16 index, int16 sub, int32 data)

Download a 32-bit signed integer using this [SDO](#).

 - const [Error](#) * [Upld32](#) (int16 index, int16 sub, int32 &data)

Upload a 32-bit signed integer using this [SDO](#).

 - const [Error](#) * [DnldFlt](#) (int16 index, int16 sub, float data)

Download a floating point value using this [SDO](#).

 - const [Error](#) * [UpldFlt](#) (int16 index, int16 sub, float &data)

Upload a floating point value using this [SDO](#).

 - const [Error](#) * [Dnld16](#) (int16 index, int16 sub, int16 data)

Download a 16-bit signed integer using this [SDO](#).

 - const [Error](#) * [Upld16](#) (int16 index, int16 sub, int16 &data)

Upload a 16-bit signed integer using this [SDO](#).

 - const [Error](#) * [Dnld8](#) (int16 index, int16 sub, int8 data)

Download an 8-bit signed integer using this [SDO](#).

 - const [Error](#) * [Upld8](#) (int16 index, int16 sub, int8 &data)

Upload an 8-bit signed integer using this [SDO](#).

 - void [SetTimeout](#) (Timeout to)

Set the timeout used with this [SDO](#).

 - Timeout [GetTimeout](#) (void)

Get the timeout used with this [SDO](#).

 - const [Error](#) * [EnableBlkUpld](#) (void)

Enable the use of block uploads with this [SDO](#) object.

 - const [Error](#) * [DisableBlkUpld](#) (void)

Disable the use of block uploads with this [SDO](#) object.

 - const [Error](#) * [EnableBlkDnld](#) (void)

Enable the use of block downloads with this [SDO](#) object.

 - const [Error](#) * [DisableBlkDnld](#) (void)

Disable the use of block downloads with this [SDO](#) object.

 - uint8 [GetMaxRetry](#) (void)

Return the maximum number times that the [SDO](#) transfer will be attempted before returning an error.

 - void [SetMaxRetry](#) (uint8 max)

Set the maximum number of times the [SDO](#) transfer will be attempted before returning an error.

5.116.1 Detailed Description

CANopen Service Data Object ([SDO](#)).

This class represents the state of a CANopen [SDO](#) object. [SDO](#) objects are used to access the values in the object dictionary on a node. This class handles the low level protocol details of an [SDO](#) connection.

5.116.2 Constructor & Destructor Documentation

5.116.2.1 [SDO](#) (void)

Default [SDO](#) object constructor.

The [SDO](#) must be initialized by calling [SDO::Init](#) before it's actually used.

5.116.3 Member Function Documentation

5.116.3.1 `const Error * BlockDnld (int16 index, int16 sub, int32 size, byte * data)`

Download data using this [SDO](#).

This function uses a block download protocol which makes sending large blocks of data more efficient. The data passed to this function is downloaded to the object dictionary of the CANopen node

Parameters

<i>index</i>	The index of the object to be downloaded.
<i>sub</i>	The sub-index of the object to be downloaded.
<i>size</i>	The number of bytes of data to be downloaded
<i>data</i>	A character array holding the data to be downloaded.

Returns

A valid CANopen error object.

5.116.3.2 `const Error * BlockUpld (int16 index, int16 sub, int32 & size, byte * data)`

Upload data using this [SDO](#).

This function uses a block upload protocol which makes sending large blocks of data more efficient. The specified object is upload from the CANopen node's object dictionary and stored in the array passed to this function.

Parameters

<i>index</i>	The index of the object to be uploaded.
<i>sub</i>	The sub-index of the object to be uploaded.
<i>size</i>	On entry, this should be the maximum number of bytes to upload, on successful return, this is the number of bytes actually received.
<i>data</i>	A character array which will store the uploaded data.

Returns

A valid CANopen error object.

5.116.3.3 `const Error * DisableBlkDnld (void)`

Disable the use of block downloads with this [SDO](#) object.

Returns

A CANopen error object, or null on success.

5.116.3.4 `const Error * DisableBlkUpld (void)`

Disable the use of block uploads with this [SDO](#) object.

Returns

A CANopen error object, or null on success.

5.116.3.5 `const Error * Dnld16 (int16 index, int16 sub, uint16 data)`

Download a 16-bit value using this [SDO](#).

Parameters

<i>index</i>	The index of the object in the object dictionary
<i>sub</i>	The sub-index of the object in the object dictionary
<i>data</i>	The data to be downloaded

Returns

A valid CANopen error code.

5.116.3.6 `const Error* Dnld16(int16 index, int16 sub, int16 data) [inline]`

Download a 16-bit signed integer using this [SDO](#).

Parameters

<i>index</i>	The index of the object to access
<i>sub</i>	The sub-index of the object
<i>data</i>	The data to be downloaded

Returns

A valid CANopen error code.

5.116.3.7 `const Error * Dnld32(int16 index, int16 sub, uint32 data)`

Download a 32-bit value using this [SDO](#).

Parameters

<i>index</i>	The index of the object in the object dictionary
<i>sub</i>	The sub-index of the object in the object dictionary
<i>data</i>	The data to be downloaded

Returns

A valid CANopen error code.

5.116.3.8 `const Error* Dnld32(int16 index, int16 sub, int32 data) [inline]`

Download a 32-bit signed integer using this [SDO](#).

Parameters

<i>index</i>	The index of the object to access
<i>sub</i>	The sub-index of the object
<i>data</i>	The data to be downloaded

Returns

A valid CANopen error code.

5.116.3.9 `const Error * Dnld8 (int16 index, int16 sub, uint8 data)`

Download a 8-bit value using this [SDO](#).

Parameters

<i>index</i>	The index of the object in the object dictionary
<i>sub</i>	The sub-index of the object in the object dictionary
<i>data</i>	The data to be downloaded

Returns

A valid CANopen error code.

5.116.3.10 `const Error* Dnld8 (int16 index, int16 sub, int8 data) [inline]`

Download an 8-bit signed integer using this [SDO](#).

Parameters

<i>index</i>	The index of the object to access
<i>sub</i>	The sub-index of the object
<i>data</i>	The data to be downloaded

Returns

A valid CANopen error code.

5.116.3.11 `const Error* DnldFlt (int16 index, int16 sub, float data) [inline]`

Download a floating point value using this [SDO](#).

Parameters

<i>index</i>	The index of the object to access
<i>sub</i>	The sub-index of the object
<i>data</i>	The data to be downloaded

Returns

A valid CANopen error code.

5.116.3.12 `const Error * DnldString (int16 index, int16 sub, char * data)`

Download a visible string type using the [SDO](#).

The string is assumed to be null terminated.

Parameters

<i>index</i>	The index of the object in the object dictionary
<i>sub</i>	The sub-index of the object in the object dictionary

<i>data</i>	A null terminated string to be downloaded.
-------------	--

Returns

A valid CANopen error code.

5.116.3.13 `const Error * Download (int16 index, int16 sub, int32 size, byte * data)`

Download data using this [SDO](#).

The passed array of data is downloaded to the object dictionary of a node on the network using this [SDO](#).

Parameters

<i>index</i>	The index of the object to be downloaded.
<i>sub</i>	The sub-index of the object to be downloaded.
<i>size</i>	The number of bytes of data to be downloaded
<i>data</i>	A character array holding the data to be downloaded.

Returns

A valid CANopen error object.

5.116.3.14 `const Error* Download (int16 index, int16 sub, int32 size, char * data) [inline]`

Download data using this [SDO](#).

The passed array of data is downloaded to the object dictionary of a node on the CANopen network using this [SDO](#).

Parameters

<i>index</i>	The index of the object to be downloaded.
<i>sub</i>	The sub-index of the object to be downloaded.
<i>size</i>	The number of bytes of data to be downloaded
<i>data</i>	A character array holding the data to be downloaded.

Returns

A valid CANopen error object.

5.116.3.15 `const Error * EnableBlkDnld (void)`

Enable the use of block downloads with this [SDO](#) object.

Returns

A CANopen error object, or null on success.

5.116.3.16 `const Error * EnableBlkUpld (void)`

Enable the use of block uploads with this [SDO](#) object.

Returns

A CANopen error object, or null on success.

5.116.3.17 uint8 GetMaxRetry (void) [inline]

Return the maximum number times that the [SDO](#) transfer will be attempted before returning an error.

Returns

The max number of retries

5.116.3.18 Timeout GetTimeout (void) [inline]

Get the timeout used with this [SDO](#).

Returns

The timeout in milliseconds

5.116.3.19 const Error * Init (Node * n, Timeout to = 2000)

Initialize a CANopen Service Data Object ([SDO](#)).

Parameters

<i>n</i>	Pointer to the node that this SDO is associated with.
<i>to</i>	The timeout (milliseconds) for use with this SDO .

Returns

A valid CANopen error object

5.116.3.20 void SetTimeout (Timeout to) [inline]

Set the timeout used with this [SDO](#).

Parameters

<i>to</i>	The timeout in milliseconds
-----------	-----------------------------

5.116.3.21 const Error * UpId16 (int16 index, int16 sub, uint16 & data)

Upload a 16-bit value using this [SDO](#).

Parameters

<i>index</i>	The index of the object in the object dictionary
<i>sub</i>	The sub-index of the object in the object dictionary
<i>data</i>	The uploaded data will be returned here.

Returns

A valid CANopen error code.

5.116.3.22 `const Error* Upld16 (int16 index, int16 sub, int16 & data) [inline]`

Upload a 16-bit signed integer using this [SDO](#).

Parameters

<i>index</i>	The index of the object to access
<i>sub</i>	The sub-index of the object
<i>data</i>	The data to be uploaded

Returns

A valid CANopen error code.

5.116.3.23 `const Error * Upld32 (int16 index, int16 sub, uint32 & data)`

Upload a 32-bit value using this [SDO](#).

Parameters

<i>index</i>	The index of the object in the object dictionary
<i>sub</i>	The sub-index of the object in the object dictionary
<i>data</i>	The uploaded data will be returned here.

Returns

A valid CANopen error code.

5.116.3.24 `const Error* Upld32 (int16 index, int16 sub, int32 & data) [inline]`

Upload a 32-bit signed integer using this [SDO](#).

Parameters

<i>index</i>	The index of the object to access
<i>sub</i>	The sub-index of the object
<i>data</i>	The data to be uploaded

Returns

A valid CANopen error code.

5.116.3.25 `const Error * Upld8 (int16 index, int16 sub, uint8 & data)`

Upload a 8-bit value using this [SDO](#).

Parameters

<i>index</i>	The index of the object in the object dictionary
<i>sub</i>	The sub-index of the object in the object dictionary
<i>data</i>	The uploaded data will be returned here.

Returns

A valid CANopen error code.

5.116.3.26 `const Error* Upld8 (int16 index, int16 sub, int8 & data) [inline]`

Upload an 8-bit signed integer using this [SDO](#).

Parameters

<i>index</i>	The index of the object to access
<i>sub</i>	The sub-index of the object
<i>data</i>	The data to be uploaded

Returns

A CANopen error object, or null on success.

5.116.3.27 `const Error* UpldFlt (int16 index, int16 sub, float & data) [inline]`

Upload a floating point value using this [SDO](#).

Parameters

<i>index</i>	The index of the object to access
<i>sub</i>	The sub-index of the object
<i>data</i>	The data to be uploaded

Returns

A valid CANopen error code.

5.116.3.28 `const Error * UpldString (int16 index, int16 sub, int32 & len, char * data)`

Upload a visible string type from the [SDO](#).

The only difference between this function and the lower level Upload function is that this function guarantees that there will be a zero character at the end of the string.

Parameters

<i>index</i>	The index of the object in the object dictionary
--------------	--

<i>sub</i>	The sub-index of the object in the object dictionary
<i>len</i>	Holds the size of the buffer on entry, and the length of the downloaded data on return.
<i>data</i>	The uploaded string will be returned here.

Returns

A valid CANopen error code.

5.116.3.29 `const Error * Upload (int16 index, int16 sub, int32 & size, byte * data)`

Upload data using this [SDO](#).

The value of the object is uploaded from the object dictionary of a node on the CANopen network using this [SDO](#). The results of the upload are stored in the passed buffer.

Parameters

<i>index</i>	The index of the object to be uploaded.
<i>sub</i>	The sub-index of the object to be uploaded.
<i>size</i>	On entry, this gives the maximum number of bytes of data to be uploaded. On successful return, it gives the actual number of bytes received.
<i>data</i>	A character array which will store the uploaded data.

Returns

A valid CANopen error object.

5.116.3.30 `const Error* Upload (int16 index, int16 sub, int32 & size, char * data) [inline]`

Upload data using this [SDO](#).

The value of the object is uploaded from the object dictionary of a node on the CANopen network using this [SDO](#). The results of the upload are stored in the passed buffer.

Parameters

<i>index</i>	The index of the object to be uploaded.
<i>sub</i>	The sub-index of the object to be uploaded.
<i>size</i>	The number of bytes of data to be uploaded
<i>data</i>	A character array which will store the uploaded data.

Returns

A valid CANopen error object.

The documentation for this class was generated from the following files:

- [CML_SDO.h](#)
- [SDO.cpp](#)

5.117 SDO_Error Class Reference

This class represents [SDO](#) errors.

Inheritance diagram for SDO_Error:

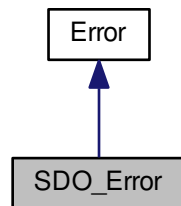

Collaboration diagram for SDO_Error:

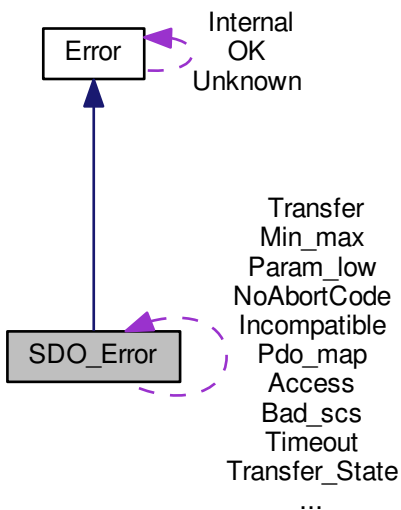

Static Public Attributes

- static const [SDO_Error NoAbortCode](#)
No abort code was specified with the SDO Abort message.
- static const [SDO_Error Togglebit](#)

- *SDO Abort - toggle bit error.*
- static const `SDO_Error Timeout`
SDO Abort - Timeout.
- static const `SDO_Error Bad_scs`
SDO Abort - Bad SCS code.
- static const `SDO_Error Block_size`
SDO Abort - Bad Block size.
- static const `SDO_Error Block_seq`
SDO Abort - Block sequence error.
- static const `SDO_Error Block_crc`
SDO Abort - Block CRC error.
- static const `SDO_Error Memory`
SDO Abort - Memory allocation failure.
- static const `SDO_Error Access`
SDO Abort - Access mode error.
- static const `SDO_Error Writeonly`
SDO Abort - Object is write only.
- static const `SDO_Error Readonly`
SDO Abort - Object is read only.
- static const `SDO_Error Bad_object`
SDO Abort - Bad object specified.
- static const `SDO_Error Pdo_map`
SDO Abort - PDO Mapping error.
- static const `SDO_Error Pdo_length`
SDO Abort - PDO Length error.
- static const `SDO_Error Bad_param`
SDO Abort - Bad parameter.
- static const `SDO_Error Incompatible`
SDO Abort - Incompatible error.
- static const `SDO_Error Hardware`
SDO Abort - Hardware error.
- static const `SDO_Error Bad_length`
SDO Abort - Bad length specified.
- static const `SDO_Error Too_long`
SDO Abort - Data too long for object.
- static const `SDO_Error Too_short`
SDO Abort - Data too short for object.
- static const `SDO_Error Subindex`
SDO Abort - Subindex is invalid.
- static const `SDO_Error Param_range`
SDO Abort - Parameter range error.
- static const `SDO_Error Param_high`
SDO Abort - Parameter too high.
- static const `SDO_Error Param_low`
SDO Abort - Parameter too low.
- static const `SDO_Error Min_max`
SDO Abort - Max less than min.

- static const [SDO_Error General](#)
SDO Abort - General error.
- static const [SDO_Error Transfer](#)
SDO Abort - Transfer error.
- static const [SDO_Error Transfer_Local](#)
SDO Abort - Local transfer error.
- static const [SDO_Error Transfer_State](#)
SDO Abort - Transfer state error.
- static const [SDO_Error OD_Gen_Fail](#)
SDO Abort - Object dictionary generation failure.
- static const [SDO_Error Unknown](#)
SDO Abort - Unknown abort code.
- static const [SDO_Error NoBlkXfers](#)
Network does not support block transfers.
- static const [SDO_Error ObjMapActive](#)
SDO Abort - sync manager mapping can't be changed while active.

Protected Member Functions

- [SDO_Error](#) (uint16 id, const char *desc)
Standard protected constructor.

Additional Inherited Members

5.117.1 Detailed Description

This class represents [SDO](#) errors.

There is one static member for each [SDO](#) abort code.

The documentation for this class was generated from the following file:

- [CML_SDO.h](#)

5.118 Semaphore Class Reference

Generic semaphore class.

Public Member Functions

- [Semaphore](#) (int32 count=0)
Create a new semaphore object.
- virtual [~Semaphore](#) ()
Free any system resources associated with this semaphore.
- const [Error](#) * [Get](#) (Timeout timeout=-1)
Get the semaphore with an optional timeout.
- const [Error](#) * [Put](#) (void)
Increase the count of the semaphore object.

5.118.1 Detailed Description

Generic semaphore class.

Semaphores can be used to allow multiple threads to share a pool of shared resources. Semaphores can be used like mutexes, however they also implement timeouts and multiple resource counts.

5.118.2 Constructor & Destructor Documentation

5.118.2.1 Semaphore (int32 count = 0)

Create a new semaphore object.

If a count is passed, then the initial semaphore count will be initialized to that value. If no count is passed, then a count of zero is used.

Parameters

<i>count</i>	The initial count of the semaphore. The semaphore's Get method may be called that many times before any thread will block on it.
--------------	--

5.118.2.2 virtual ~Semaphore () [virtual]

Free any system resources associated with this semaphore.

Any threads blocking on the semaphore should return from the [Get\(\)](#) call with an error indication.

5.118.3 Member Function Documentation

5.118.3.1 const Error* Get (Timeout timeout = -1)

Get the semaphore with an optional timeout.

An error is returned if the timeout expires before the semaphore is acquired.

Parameters

<i>timeout</i>	The timeout in milliseconds. Any negative value will cause the thread to wait indefinitely. If a timeout of zero is specified, the calling thread will return a timeout error without blocking if the semaphore is not available.
----------------	---

Returns

An error code indicating success or failure.

5.118.3.2 const Error* Put (void)

Increase the count of the semaphore object.

If any threads are pending on the object, then the highest priority one will be made eligible to run.

Returns

An error object

The documentation for this class was generated from the following file:

- [CML_Threads.h](#)

5.119 ServoLoopConfig Struct Reference

This structure holds configuration info about specific parts of the velocity and position loops.

Public Attributes

- [int32 servoLoopConfig](#)

Servo Loop Configuration This paramater it set up as follows: Bit 0: If set, disables the velocity loop gains.

5.119.1 Detailed Description

This structure holds configuration info about specific parts of the velocity and position loops.

5.119.2 Member Data Documentation

5.119.2.1 int32 servoLoopConfig

Servo Loop Configuration This paramater it set up as follows: Bit 0: If set, disables the velocity loop gains.

The velocity loop command feed forward gain is still active as are the velocity loop output filters. Bit 1: If set, this enables the position loop I and D gains. If clear, these params are treated as zeros. Bit 2-31: Reserved for future use

The documentation for this struct was generated from the following file:

- [CML_AmpStruct.h](#)

5.120 SoftPosLimit Struct Reference

Software limit switch configuration.

Public Member Functions

- [SoftPosLimit](#) (void)

Default constructor. Simply sets both limits to zero.

Public Attributes

- [uunit neg](#)

Negative limit position.

- [uunit pos](#)
Positive limit position.
- [uunit accel](#)
Software limit acceleration.
- [uunit motorPosWrap](#)
Motor position wrap value.
- [uunit loadPosWrap](#)
Load position wrap. Same as above except for load encoder.
- [uunit macroEncoderCapture](#)
MACRO encoder capture configuration.

5.120.1 Detailed Description

Software limit switch configuration.

This structure may be used to pass software limit switch settings to an [Amp](#) object using the functions [Amp::SetSoftLimits](#) and [Amp::GetSoftLimits](#)

5.120.2 Member Data Documentation

5.120.2.1 [uunit accel](#)

Software limit acceleration.

This parameter defines the acceleration value that will be used to stop the motor at the software limit position. Note that this parameter was added in amplifier firmware version 4.60. Before that version the older current based software limit processing was used.

If this parameter is set to zero (the default) then the software limits will act like virtual limit switches. If the motor position exceeds the limit position then the amplifier will refuse to output current in the limit direction.

5.120.2.2 [uunit macroEncoderCapture](#)

MACRO encoder capture configuration.

Configures the MACRO amplifier's encoder capture circuit. Only implemented on MACRO amplifiers.

5.120.2.3 [uunit motorPosWrap](#)

Motor position wrap value.

Actual motor position will wrap back to zero when this value is reached. Setting this value to zero disables this feature. (Units counts). This feature is only implemented on the 8367 hardware with firmware 0.42 or later

5.120.2.4 [uunit neg](#)

Negative limit position.

Any time the motors actual position is less than this value, a negative software limit condition will be in effect on the amplifier.

5.120.2.5 uunit pos

Positive limit position.

Any time the motors actual position is greater then this value, a positive software limit condition will be in effect on the amplifier.

The documentation for this struct was generated from the following file:

- [CML_AmpStruct.h](#)

5.121 Thread Class Reference

Virtual class which provides multi-tasking.

Inheritance diagram for Thread:

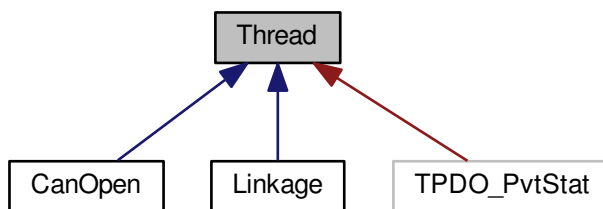

Public Member Functions

- [Thread](#) (void)
Create a new thread.
- virtual [~Thread](#) ()
Clean up any allocated resources.
- const [Error](#) * [setPriority](#) (int pri)
Set the thread priority.
- const [Error](#) * [start](#) (void)
Make this thread eligible to run.
- const [Error](#) * [stop](#) (Timeout to=1000)
Stop this thread.
- virtual void [run](#) (void)=0
When a new thread is started, this function will be called.
- void [__run](#) (void)
This is an internal function which should not be called directly.

Static Public Member Functions

- static const [Error](#) * [sleep](#) (Timeout to)
Cause the calling thread to sleep for a specified number of milliseconds.
- static [uint32](#) [getTimeMS](#) (void)
Return the current time in millisecond units.

5.121.1 Detailed Description

Virtual class which provides multi-tasking.

To add a new thread to a program, create a new class that is derived from [Thread](#). The new thread of execution will start when the [start\(\)](#) member function is called. This new thread of execution will start with the [run\(\)](#) member function and will run concurrently with the rest of the system. When (if) the run method returns, the new thread will be terminated.

5.121.2 Constructor & Destructor Documentation

5.121.2.1 [Thread](#) (void)

Create a new thread.

The new thread will not start executing until the start member function of this class is called. The default thread priority will be set to 5.

5.121.3 Member Function Documentation

5.121.3.1 [static uint32 getTimeMS](#) (void) [static]

Return the current time in millisecond units.

The value returned may be offset by a consistent, but arbitrary value. This makes it useful for checking relative times, but not useful for absolute time calculations.

Returns

The time in millisecond units

5.121.3.2 [virtual void run](#) (void) [pure virtual]

When a new thread is started, this function will be called.

All of the thread specific code should be contained in this function. If the [run\(\)](#) method ever returns, the thread will be destroyed.

5.121.3.3 [const Error* setPriority](#) (int *pri*)

Set the thread priority.

This function should be called before the thread is started if the default priority (5) is not acceptable.

Parameters

<i>pri</i>	The priority for this thread to run at. The range is 0 to 9 where 0 is a very low priority task, and 9 is a critically high priority.
------------	---

Returns

An error object is returned indicating the success of the call.

5.121.3.4 `static const Error* sleep (Timeout to)` [*static*]

Cause the calling thread to sleep for a specified number of milliseconds.

Parameters

<i>to</i>	The time to sleep, in milliseconds.
-----------	-------------------------------------

Returns

An error object is returned indicating the success of the call.

5.121.3.5 `const Error* start (void)`

Make this thread eligible to run.

The new thread will be created if possible and identified to the operating system as eligible to run. When the thread actually starts, the `run()` method will be called. Note that depending on the priority of the thread and of the calling task, the `run()` function may or may not be called before `start()` returns.

Returns

An error object is returned indicating the success of the call.

5.121.3.6 `const Error* stop (Timeout to = 1000)`

Stop this thread.

The thread will have exited by the time this function returns. If the calling thread is the thread being stopped, then this function will not return.

Parameters

<i>to</i>	The amount of time to wait for the thread to stop before returning an error (default 1 second).
-----------	---

Returns

An error object is returned indicating the success of the call.

The documentation for this class was generated from the following file:

- [CML_Threads.h](#)

5.122 ThreadError Class Reference

Errors related to the multi-threaded libraries.

Inheritance diagram for ThreadError:

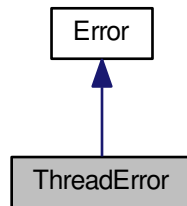

Collaboration diagram for ThreadError:

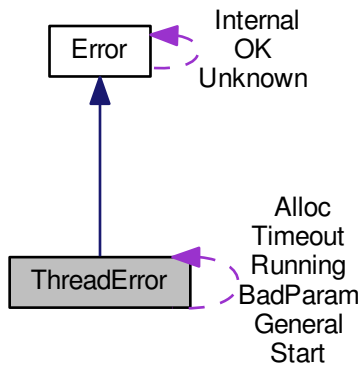

Static Public Attributes

- static const [ThreadError Start](#)
Error starting the thread.
- static const [ThreadError Running](#)
Thread has already been started.
- static const [ThreadError Timeout](#)
Timeout waiting on semaphore.
- static const [ThreadError General](#)

General failure.

- static const [ThreadError BadParam](#)

Bad parameter passed to a thread function.

- static const [ThreadError Alloc](#)

Error allocating memory for thread data.

Additional Inherited Members

5.122.1 Detailed Description

Errors related to the multi-threaded libraries.

The documentation for this class was generated from the following file:

- [CML_Threads.h](#)

5.123 TPDO Class Reference

Transmit [PDO](#) (transmitted by node, received by this software).

Inheritance diagram for TPDO:

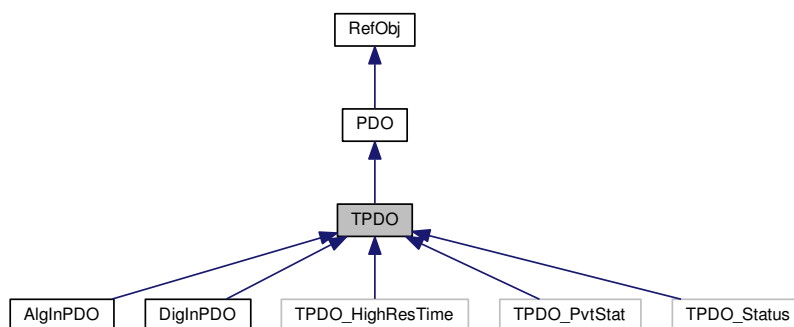

Collaboration diagram for TPDO:

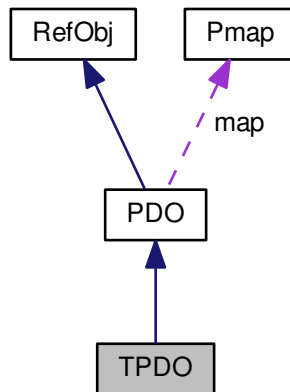

Public Member Functions

- **TPDO** ()
Default constructor.
- **bool IsTxPDO** (void)
Always return true for transmit PDO objects.
- **TPDO** (uint32 cobID)
Calls `Init()` at construction time.
- **virtual ~TPDO** ()
Virtual destructor.
- **virtual const Error * Init** (uint32 cobID)
Initialize the PDO.
- **virtual void SetRtrOk** (int ok)
Enable or disable RTR requests for this PDO.
- **virtual void Received** ()
This function is called by the Network read thread when this PDO has been received.
- **void ProcessData** (uint8 *data, int ct, uint32 time)
Process data received from the network.
- **virtual const Error * Request** (Network &net)
Send a remote request for this PDO if the network supports it.

Protected Attributes

- **uint32 timestamp**
Timestamp of received frame if available.

Additional Inherited Members

5.123.1 Detailed Description

Transmit [PDO](#) (transmitted by node, received by this software).

5.123.2 Member Function Documentation

5.123.2.1 void ProcessData (uint8 * data, int ct, uint32 time)

Process data received from the network.

This function is called by the network object when new data is received for this [PDO](#). It updates the values of the variables mapped to the [PDO](#) and calls the virtual [Received\(\)](#) function.

Parameters

<i>data</i>	Pointer to the newly received PDO data.
<i>ct</i>	Size of the PDO data in bytes.
<i>time</i>	System time stamp indicating the time of reception

5.123.2.2 virtual void Received (void) [inline],[virtual]

This function is called by the [Network](#) read thread when this [PDO](#) has been received.

Reimplemented in [IOModule::AlInPDO](#), and [IOModule::DigInPDO](#).

5.123.2.3 virtual void SetRtrOk (int ok) [inline],[virtual]

Enable or disable RTR requests for this [PDO](#).

Parameters

<i>ok</i>	zero for no RTR, non-zero for RTR allowed
-----------	---

The documentation for this class was generated from the following files:

- [CML_PDO.h](#)
- [PDO.cpp](#)

5.124 TrackingWindows Struct Reference

Position and velocity error windows.

Public Member Functions

- [TrackingWindows](#) (void)

Default constructor for tracking window structure.

Public Attributes

- [uunit trackErr](#)
Tracking error window.
- [uunit trackWarn](#)
Position warning window.
- [uunit settlingWin](#)
Position tracking & settling window.
- [uint16 settlingTime](#)
Position tracking & settling time (ms).
- [uunit velWarnWin](#)
Velocity warning window See [Amp::SetVelocityWarnWindow](#) for more information.
- [uint16 velWarnTime](#)
Velocity warning window time See [Amp::SetVelocityWarnTime](#) for more information.

5.124.1 Detailed Description

Position and velocity error windows.

5.124.2 Constructor & Destructor Documentation

5.124.2.1 TrackingWindows (void)

Default constructor for tracking window structure.

This simply sets all tracking window parameter default values of zero.

5.124.3 Member Data Documentation

5.124.3.1 uint16 settlingTime

Position tracking & settling time (ms).

See [Amp::SetSettlingTime](#) for more info

5.124.3.2 uunit settlingWin

Position tracking & settling window.

See [Amp::SetSettlingWindow](#) for more information

5.124.3.3 uunit trackErr

Tracking error window.

See [Amp::SetPositionErrorWindow](#) for more information

5.124.3.4 uunit trackWarn

Position warning window.

See [Amp::SetPositionWarnWindow](#) for more information

The documentation for this struct was generated from the following files:

- [CML_AmpStruct.h](#)
- [AmpStruct.cpp](#)

5.125 Trajectory Class Reference

[Trajectory](#) information class.

Inheritance diagram for Trajectory:

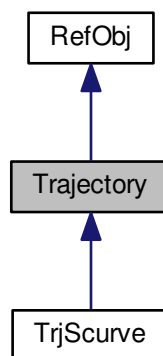

Collaboration diagram for Trajectory:

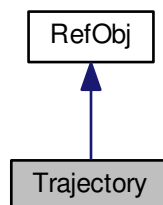

Public Member Functions

- virtual `~Trajectory ()`
Virtual destructor.
- virtual const `Error * StartNew (void)`
Start a new trajectory.
- virtual void `Finish (void)`
Trajectory finished.
- virtual bool `UseVelocityInfo (void)`
This function indicates whether the velocity information returned by NextSegment should be used.
- virtual int `MaximumBufferPointsToUse (void)`
This function allows a trajectory object to effectively reduce the size of the amplifier's internal trajectory buffer.
- virtual const `Error * NextSegment (uunit &pos, uunit &vel, uint8 &time)=0`
Get the next segment of position, velocity & time info.

Additional Inherited Members

5.125.1 Detailed Description

[Trajectory](#) information class.

One of the control modes supported by the Copley Controls amplifiers is called interpolated position mode. This allows complex trajectories to be generated by the CANopen master controller, and streamed to one or more amplifiers in real time. Each point on the trajectory contains three pieces of information; Position, Velocity, and Time until the next point. For this reason, these trajectories are also often called PVT profiles.

The [Amp](#) object contains support for streaming a PVT trajectory down to the amplifier automatically (see [Amp::SendTrajectory](#)). This virtual class provides the interface through which the trajectory data is retrieved by the [Amp](#) object.

Note that this pure virtual class provides no actual implementation code. The calculation of the trajectory points is the responsibility of the inheriting class.

5.125.2 Member Function Documentation

5.125.2.1 virtual void Finish (void) [inline],[virtual]

[Trajectory](#) finished.

This function is called by the [Amp](#) object when it is finished with the trajectory object and no longer holding a reference to it. Typically, this will happen after the [Trajectory::NextSegment](#) function has returned a zero time value, although it can also occur when some external event causes the [Amp](#) object to abort a running trajectory.

Once the [Amp](#) object calls [Trajectory::Finish](#) it will clear it's reference to the trajectory object. No further access to the trajectory object will be made after Finish is called.

Reimplemented in [TrjScurve](#).

5.125.2.2 virtual int MaximumBufferPointsToUse (void) [inline],[virtual]

This function allows a trajectory object to effectively reduce the size of the amplifier's internal trajectory buffer.

Normally it's desirable to download as many points as possible to the amplifier at once. For some applicaitons however, the trajectory information is calculated in real time and the amplifier's buffer causes unacceptable latency. For such

applications this function may be used to reduce the delay between calculating trajectory points and the amplifier's acting on them.

Note that the amplifier requires some buffering of points in order to interpolate between them. This function should never return a value less than 2 or a trajectory underflow will certainly occur.

Returns

The maximum number of trajectory points that should be stored in the amplifier at any time. By default this returns a very large number which ensures that the amplifier's full buffer will be used.

5.125.2.3 `virtual const Error* NextSegment (uunit & pos, uunit & vel, uint8 & time) [pure virtual]`

Get the next segment of position, velocity & time info.

Note that this function will be called from the high priority CANopen receiver task. Therefore, no lengthy processing should be done here.

Parameters

<i>pos</i>	The new position value is returned here. This parameter is specified in "user units". See Amp::SetCountsPerUnit for details.
<i>vel</i>	The new velocity value is returned here. This parameter is specified in "user units". See Amp::SetCountsPerUnit for details. Note that the velocity data will be ignored if the function UseVelocityInfo() returns false. In this case the amplifier will use linear interpolation between points.
<i>time</i>	The segment time is returned here. This is in milliseconds and ranges from 1 to 255. If zero is returned, this is the last frame in the profile.

Returns

An error object. If this is not [Error::OK](#), then the segment data is assumed to be invalid.

Implemented in [TrjScurve](#).

5.125.2.4 `virtual const Error* StartNew (void) [inline], [virtual]`

Start a new trajectory.

This function is called by [Amp::SendTrajectory](#) before the first call to [Trajectory::NextSegment](#). It gives the trajectory object a chance to return an error indicating that it isn't ready to be sent.

Returns

An error pointer if the trajectory object is not available, or NULL if it is ready to be sent.

Reimplemented in [TrjScurve](#).

5.125.2.5 `virtual bool UseVelocityInfo (void) [inline], [virtual]`

This function indicates whether the velocity information returned by [NextSegment](#) should be used.

If this returns true, then the amplifier will operate in PVT mode and use cubic polynomial interpolation between trajectory segments. If this returns false, then the velocity returned by [NextSegment](#) will be ignored, and the amplifier will run in PT mode using linear interpolation between sets of points.

Returns

true if velocity information should be used (default), or false if velocities should be ignored.

The documentation for this class was generated from the following file:

- [CML_Trajectory.h](#)

5.126 TrjError Class Reference

This class represents error conditions reported by the trajectory classes.

Inheritance diagram for TrjError:

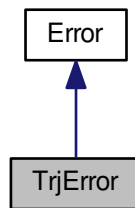

Collaboration diagram for TrjError:

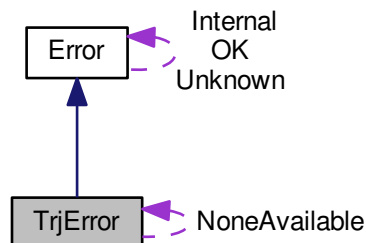
**Static Public Attributes**

- static const [TrjError NoneAvailable](#)

No trajectory information available at the moment.

Protected Member Functions

- [TrjError](#) (uint16 id, const char *desc)

Standard protected constructor.

Additional Inherited Members

5.126.1 Detailed Description

This class represents error conditions reported by the trajectory classes.

5.126.2 Member Data Documentation

5.126.2.1 `const TrjError NoneAvailable` [static]

No trajectory information available at the moment.

This error code may be returned from [Trajectory::NextSegment](#) to limit the amount of trajectory information uploaded to the amplifier at one time. The [Amp](#) object will not treat this as an error condition, but will stop requesting trajectory data until the next PVT status [PDO](#) is received.

The documentation for this class was generated from the following file:

- [CML_Trajectory.h](#)

5.127 TrjScurve Class Reference

Asymmetric S-curve profile generator.

Inheritance diagram for TrjScurve:

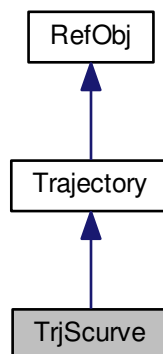

Collaboration diagram for TrjScurve:

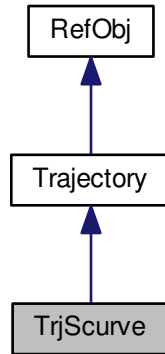

Public Member Functions

- [TrjScurve](#) ()
S-curve trajectory default constructor.
- void [SetStartPos](#) (uunit s)
Set the trajectory starting position.
- uunit [GetStartPos](#) (void)
Return the current starting position of the trajectory.
- const [Error](#) * [Calculate](#) (uunit start, uunit end, uunit vel, uunit acc, uunit dec, uunit jrk)
Calculate a new S-curve profile and also set it's starting position.
- const [Error](#) * [Calculate](#) (uunit dist, uunit vel, uunit acc, uunit dec, uunit jrk)
Calculate a new S-curve profile.
- const [Error](#) * [StartNew](#) (void)
Reset this object so it may be passed to an amplifier.
- void [Finish](#) (void)
Notify the trajectory object that it is no longer in use.
- const [Error](#) * [NextSegment](#) (uunit &pos, uunit &vel, uint8 &time)
Get the next PVT segment for this s-curve profile.

Additional Inherited Members

5.127.1 Detailed Description

Asymmetric S-curve profile generator.

A symmetric S-curve profile uses the same constraint for acceleration & deceleration. Asymmetric profiles use different acceleration & deceleration values. Copley amplifiers are able to calculate symmetric profiles internally, however if asymmetric s-curve profiles are required then they must be calculate external to the amplifier, and passed to it using PVT profile mode.

This class extends the generic [Trajectory](#) class, and provides the code necessary to calculate an asymmetric s-curve profile. Since it extends the [Trajectory](#) object, it may be passed to the [Amp::SendTrajectory](#) function.

Internally, the s-curve profile is stored as an absolute move from some starting position. This allows the same trajectory object to be reused for multiple moves of the same distance from different starting positions. The starting position may be either passed to the [TrjScurve::Calculate](#) function, or set using [TrjScurve::SetStartPos](#).

5.127.2 Constructor & Destructor Documentation

5.127.2.1 TrjScurve (void)

S-curve trajectory default constructor.

This simply sets the profile to zero length with a starting position of zero.

5.127.3 Member Function Documentation

5.127.3.1 const Error * Calculate (uunit start, uunit end, uunit vel, uunit acc, uunit dec, uunit jrk)

Calculate a new S-curve profile and also set it's starting position.

Parameters

<i>start</i>	The profile starting position.
<i>end</i>	The profile ending position.
<i>vel</i>	The maximum allowable velocity for the move.
<i>acc</i>	The maximum allowable acceleration for the move.
<i>dec</i>	The maximum allowable deceleration for the move.
<i>jrk</i>	The maximum jerk (rate of change of acceleration) for the move.

Returns

A pointer to an error object, or NULL on success.

5.127.3.2 const Error * Calculate (uunit dist, uunit maxVel, uunit maxAcc, uunit maxDec, uunit maxJrk)

Calculate a new S-curve profile.

The resulting profile may then be sent to an [Amp](#) object using the [Amp::SendTrajectory](#) method.

Note, all profile parameters are passed in 'user units'. See the documentation for [Amp::SetCountsPerUnit](#) for details.

Note also that this function calculate the profile as an absolute move from the starting position that is set using [TrjScurve::SetStartPos](#). The same profile may be used multiple times with different starting positions without calling the [TrjScurve::Calculate](#) function again.

Parameters

<i>dist</i>	The distance to move.
<i>maxVel</i>	The maximum allowable velocity for the move.

<i>maxAcc</i>	The maximum allowable acceleration for the move.
<i>maxDec</i>	The maximum allowable deceleration for the move.
<i>maxJrk</i>	The maximum jerk (rate of change of acceleration) for the move.

Returns

A pointer to an error object, or NULL on success.

The distance will always be met exactly. This may be either positive or negative.

The velocity, acceleration, deceleration and jerk values are constraints and won't be exceeded. These must all be positive numbers greater than zero.

5.127.3.3 uunit GetStartPos (void)

Return the current starting position of the trajectory.

The starting position will either be the value set using [TrjScurve::SetStartPos](#), or the value set using [TrjScurve::Calculate](#). If neither has been called since construction, then the starting position will be zero.

Returns

The trajectory starting position.

5.127.3.4 void SetStartPos (uunit s)

Set the trajectory starting position.

S-curve profiles are internally stored as absolute moves of some length. This allows them to be used multiple times with different starting positions.

This function may be used to update the starting position of the trajectory.

Parameters

<i>s</i>	The new starting position
----------	---------------------------

5.127.3.5 const Error * StartNew (void) [virtual]

Reset this object so it may be passed to an amplifier.

This will return an error if the trajectory has not yet been calculated, or if it is currently being sent to another amp.

Returns

A pointer to an error object, or NULL on success

Reimplemented from [Trajectory](#).

The documentation for this class was generated from the following files:

- [CML_TrjScurve.h](#)
- [TrjScurve.cpp](#)

5.128 UstepConfig Struct Reference

Configuration structure used to set up the microstepper.

Public Member Functions

- [UstepConfig](#) (void)
Default constructor.

Public Attributes

- [uint32 maxVelAdj](#)
Maximum Velocity adjustment.
- [uint16 ustepPGainOutLoop](#)
Proportional Gain for stepper outer loop.
- [int16 detentCorrectionGain](#)
Detent correction Gain factor.
- [uint16 ustepConfigAndStatus](#)
Stepper config and status Bit mapped as follows (Bit 0 Use the encoder input for phase compensation if enabled).

5.128.1 Detailed Description

Configuration structure used to set up the microstepper.

These settings may be up/download from the amplifier using the functions [Amp::SetUstepConfig](#) and [Amp::GetUstepConfig](#).

5.128.2 Constructor & Destructor Documentation

5.128.2.1 [UstepConfig](#) (void) `[inline]`

Default constructor.

Initializes all structure elements to zero.

5.128.3 Member Data Documentation

5.128.3.1 [uint32 maxVelAdj](#)

Maximum Velocity adjustment.

This is the maximum velocity adjustment made by the stepper outer position loop when enabled. This parameter is only used when the stepper outer loop ios engaged. (when bit 1 of ustepConfig ustepConfigAndStatus is set)

5.128.3.2 [uint16 ustepConfigAndStatus](#)

Stepper config and status Bit mapped as follows (Bit 0 Use the encoder input for phase compensation if enabled).

Pure stepper if disabled (Bit 1 Use encoder outer loop to adjust the stepper position based on position error. When this bit is set, the gain value maximum velocity adjustment is multiplied by the position error, and the result is a velocity that is added to the microstepping position bits 2 - 15 reserved)

5.128.3.3 uint16 ustepPGainOutLoop

Proportional Gain for stepper outer loop.

This parameter gives the gain used for calculating a velocity adjustment based on position error. This parameter is only used when stepper outer loop is engaged (when bit 1 of ustepConfig ustepConfigAndStatus is set)

The documentation for this struct was generated from the following file:

- [CML_AmpStruct.h](#)

5.129 VelLoopConfig Struct Reference

This structure holds the velocity loop configuration parameters specific to the Copley amplifier.

Public Member Functions

- [VelLoopConfig](#) (void)
Default constructor.

Public Attributes

- [int16 kp](#)
Proportional gain.
- [int16 ki](#)
Integral gain.
- [int16 kaff](#)
Acceleration feed forward.
- [int16 velCmdff](#)
Velocity loop command feed forward The input command (after limiting) to the velocity loop is scaled by this value and added to the output of the velocity loop.
- [int16 shift](#)
Output shift value.
- [int16 viDrain](#)
Velocity loop drain value for integral sum. Set to 0 to disable.
- [uunit maxVel](#)
Maximum allowed velocity.
- [uunit maxAcc](#)
Maximum allowed acceleration.
- [uunit maxDec](#)
Maximum allowed deceleration This value limits the rate of change of the velocity command input to the velocity loop.
- [uunit estopDec](#)
Deceleration used for emergency stop When the position loop is driving the velocity loop this value is only used for tracking error conditions.

5.129.1 Detailed Description

This structure holds the velocity loop configuration parameters specific to the Copley amplifier.

The velocity loop is one of three servo control loops used by the amplifier to control a motor. The configuration parameters used by this control loop allow the servo performance to be 'tuned' for various motors and loads.

The amplifier member functions [Amp::GetVelLoopConfig](#) and [Amp::SetVelLoopConfig](#) are used to read and write this data to the amplifier.

5.129.2 Constructor & Destructor Documentation

5.129.2.1 VelLoopConfig(void) `[inline]`

Default constructor.

Simply initializes all members to zero.

5.129.3 Member Data Documentation

5.129.3.1 uunit estopDec

Deceleration used for emergency stop When the position loop is driving the velocity loop this value is only used for tracking error conditions.

If a tracking error occurs, the velocity loop takes over control and drives to zero velocity using this deceleration value.

Setting this value to zero indicates that the deceleration is unlimited.

This parameter is specified in "user units". See [Amp::SetCountsPerUnit](#) for details.

5.129.3.2 uunit maxAcc

Maximum allowed acceleration.

This value limits the rate of change of the velocity command input to the velocity loop. It is used when the magnitude of the command is increasing.

Note that the acceleration & deceleration limits are NOT used when the position loop is driving the velocity loop.

This parameter is specified in "user units". See [Amp::SetCountsPerUnit](#) for details.

5.129.3.3 uunit maxDec

Maximum allowed deceleration This value limits the rate of change of the velocity command input to the velocity loop.

It is used when the magnitude of the command is decreasing.

Note that the acceleration & deceleration limits are not used when the position loop is driving the velocity loop.

This parameter is specified in "user units". See [Amp::SetCountsPerUnit](#) for details.

5.129.3.4 uunit maxVel

Maximum allowed velocity.

This value is used to limit the velocity command before the velocity loop uses it to calculate output current. When running in a position mode (normal for CAN operation) The velocity command is the output from the position loop. This command is clipped by this value before it is passed to the velocity loop.

This parameter is specified in "user units". See [Amp::SetCountsPerUnit](#) for details.

5.129.3.5 int16 shift

Output shift value.

The output of the loop is downshifted this many bits to get the current loop command

5.129.3.6 int16 velCmdff

Velocity loop command feed forward The input command (after limiting) to the velocity loop is scaled by this value and added to the output of the velocity loop.

The documentation for this struct was generated from the following file:

- [CML_AmpStruct.h](#)

5.130 WinUdpEcatHardware Class Reference

This class provides an interface to the Ethernet ports on a windows system.

Inheritance diagram for WinUdpEcatHardware:

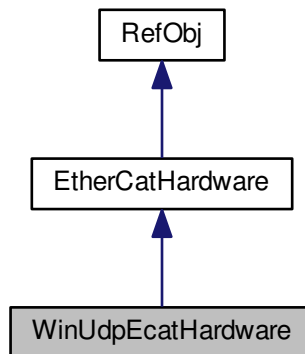

Collaboration diagram for WinUdpEcatHardware:

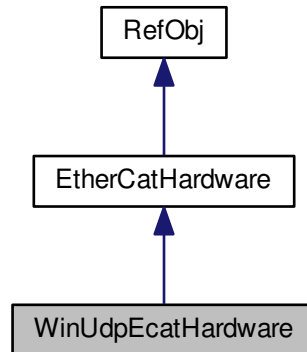

Public Member Functions

- [WinUdpEcatHardware](#) (const char *name=0)
Create an [EtherCAT](#) hardware interface which uses UDP formatted messages.

Additional Inherited Members

5.130.1 Detailed Description

This class provides an interface to the Ethernet ports on a windows system.

It can be used to send and received formatted [EtherCAT](#) packets.

Windows doesn't allow raw Ethernet packets to be sent, so this class packages the [EtherCAT](#) packets into a UDP wrapper.

5.130.2 Constructor & Destructor Documentation

5.130.2.1 [WinUdpEcatHardware](#) (const char * name = 0)

Create an [EtherCAT](#) hardware interface which uses UDP formatted messages.

This is the only type of [EtherCAT](#) interface that can be used under Windows without installing special drivers.

The low level [EtherCAT](#) protocol normally does not use an IP address, however since this driver transmits [EtherCAT](#) packets over UDP/IP, the Ethernet interface used with this driver must have a valid IP address assigned. In addition, the network mask associated with the Ethernet interface should be defined in such a way that no other network interface on the same PC is a member of the same network. That is, if multiple interfaces are installed then they should be allocated to separate networks.

i.e. (IP1 & mask1) != (IP2 & mask2) where IP1 and mask1 are the IP address and net mask of the first interface, and IP2 and mask2 are for the second interface.

For example, the following two interfaces are on different networks: IP: 192.168.1.1 mask: 255.255.255.0 IP: 192.168.2.1 mask: 255.255.255.0

but the following two interfaces are on the same network: IP: 192.168.1.1 mask: 255.255.255.0 IP: 192.168.1.2 mask: 255.255.255.0

This is important because this drive has no direct control of which interface the packets are being sent out. This is entirely controlled by the upper layer routing algorithms in the windows network stack.

The name parameter passed to this function can be used to identify which interface this object should bind to. It can take any of the following forms:

- If not specified, then the first valid interface found will be used. This is useful if there's only one interface on the PC.
- If of the form; eth0, eth1, eth2, etc, then the nth valid interface will be used.
- For more control, the IP address of the desired interface can be passed. This should be sent as a string in dotted decimal notation. For example: "192.168.1.1"

Parameters

<i>name</i>	Used to identify the Ethernet interface as described above.
-------------	---

The documentation for this class was generated from the following files:

- ecat_winudp.h
- ecat_winudp.cpp

Chapter 6

File Documentation

6.1 Amp.cpp File Reference

This file provides most of the implementation for the Copley Amplifier object.

Include dependency graph for Amp.cpp:

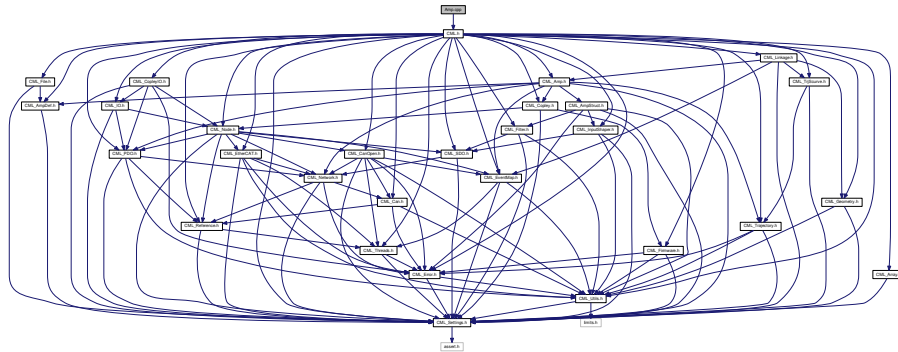

6.1.1 Detailed Description

This file provides most of the implementation for the Copley Amplifier object. Since the [Amp](#) object is large and complex, it's member functions have been split into several files:

- This file: Contains the core code.
- [AmpParam.cpp](#): Holds functions used to upload and download various blocks of amplifier parameters.
- [AmpPDO.cpp](#): Contains functions used to implement the various [PDO](#) objects used in conjunction with the [Amp](#) object.

6.2 AmpFile.cpp File Reference

This file contains code used to read a CME-2 .ccx amplifier file.

6.6 AmpPVT.cpp File Reference

This file contains the code used by the [Amp](#) object to stream PVT trajectory profiles over the CANopen network.

Include dependency graph for AmpPVT.cpp:

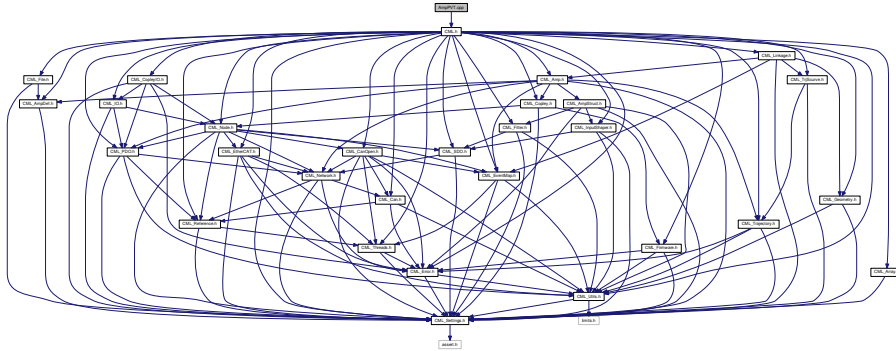

6.6.1 Detailed Description

This file contains the code used by the [Amp](#) object to stream PVT trajectory profiles over the CANopen network.

6.7 AmpStruct.cpp File Reference

This file contains the AMP object methods used to upload / download structures containing groups of amplifier parameters.

Include dependency graph for AmpStruct.cpp:

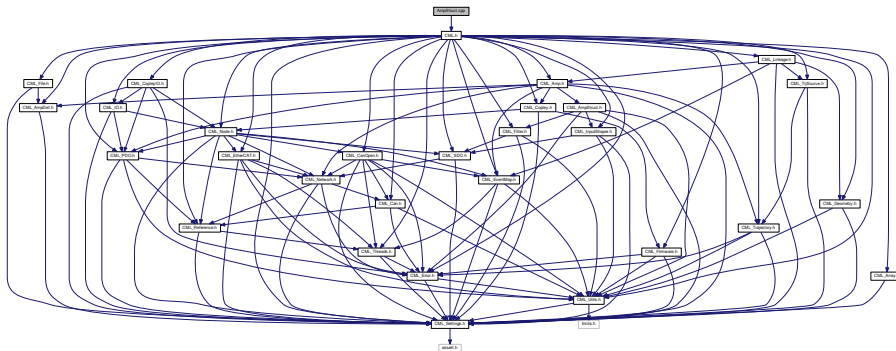

6.7.1 Detailed Description

This file contains the AMP object methods used to upload / download structures containing groups of amplifier parameters.

6.8 AmpUnits.cpp File Reference

This file contains the AMP object methods used to handle unit conversions.

Include dependency graph for AmpUnits.cpp:

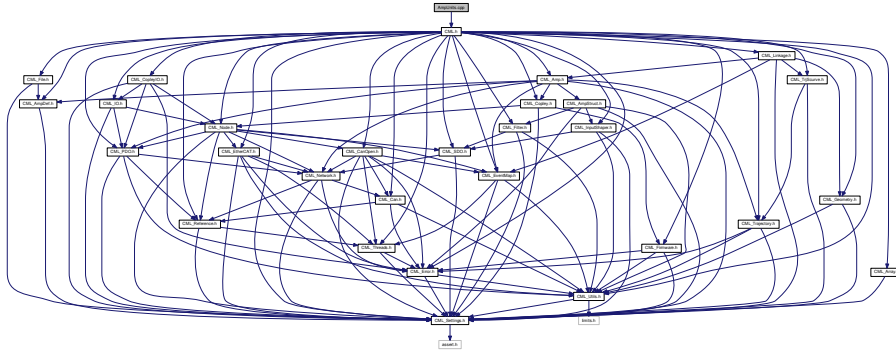

6.8.1 Detailed Description

This file contains the AMP object methods used to handle unit conversions.

6.9 AmpVersion.cpp File Reference

This file contains some rules used by the [Amp](#) object to determine if certain features are supported by the amplifier based on its model number and firmware version number.

Include dependency graph for AmpVersion.cpp:

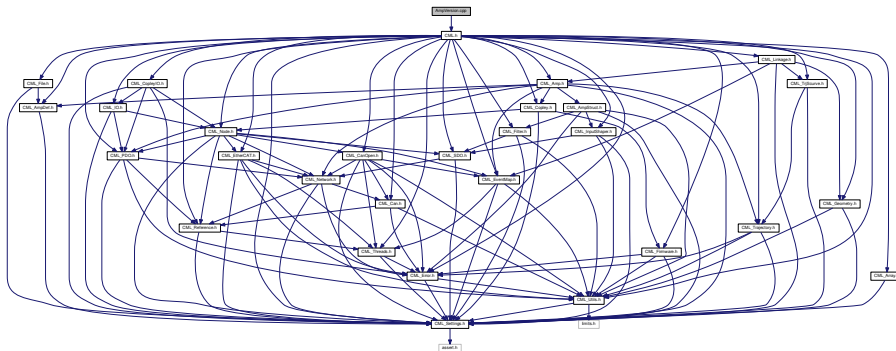

6.9.1 Detailed Description

This file contains some rules used by the [Amp](#) object to determine if certain features are supported by the amplifier based on its model number and firmware version number.

Include dependency graph for can_copley.h:

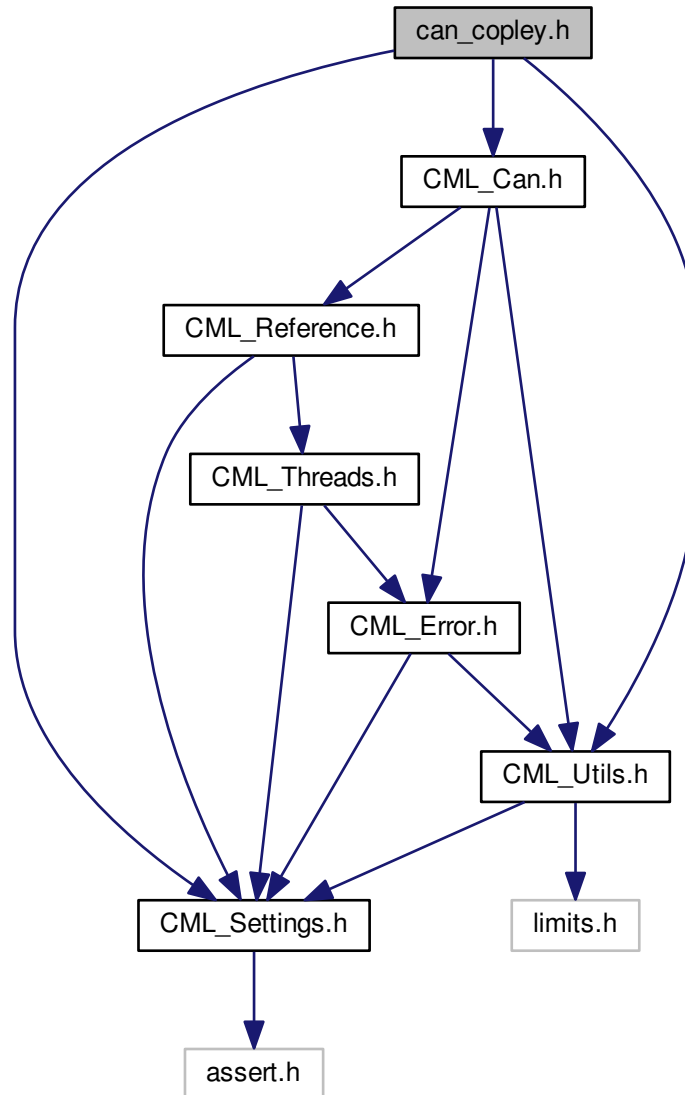

Classes

- class [CopleyCAN](#)

This class extends the generic [CanInterface](#) class into a working interface for the Copley can device driver.

6.11.1 Detailed Description

CAN hardware interface for the Copley Controls CAN card.

6.12 can_ixxat.h File Reference

CAN hardware interface for the Ixxat CAN driver.

Include dependency graph for can_ixxat.h:

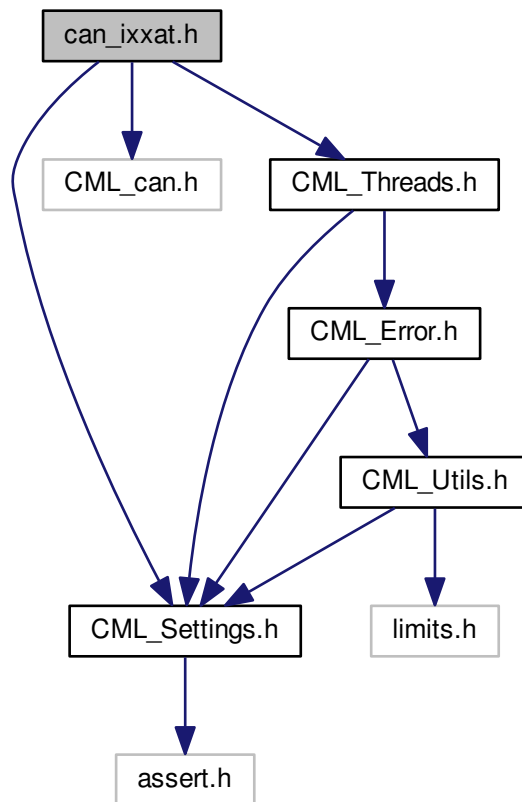

Classes

- class [IxxatCAN](#)
Ixxat specific CAN interface.

Macros

- `#define IXXAT_RX_QUEUE_SZ 50`

This gives the size of the CAN message receive queue used for Ixxat cards.

6.12.1 Detailed Description

CAN hardware interface for the Ixxat CAN driver.

6.13 can_ixxat_v3.h File Reference

CAN hardware interface for the Ixxat CAN driver.

Include dependency graph for can_ixxat_v3.h:

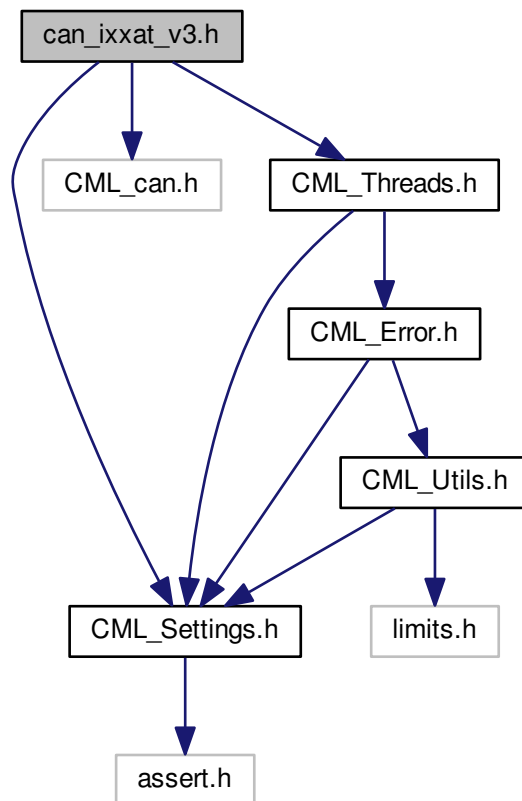

Classes

- class [IxxatCANV3](#)

Ixxat specific CAN interface.

Macros

- `#define IXXAT_RX_QUEUE_SZ 50`

This gives the size of the CAN message receive queue used for lxxat cards.

6.13.1 Detailed Description

CAN hardware interface for the lxxat CAN driver.

6.14 can_kvaser.h File Reference

CAN hardware interface for the Kvaser CAN driver.

Include dependency graph for can_kvaser.h:

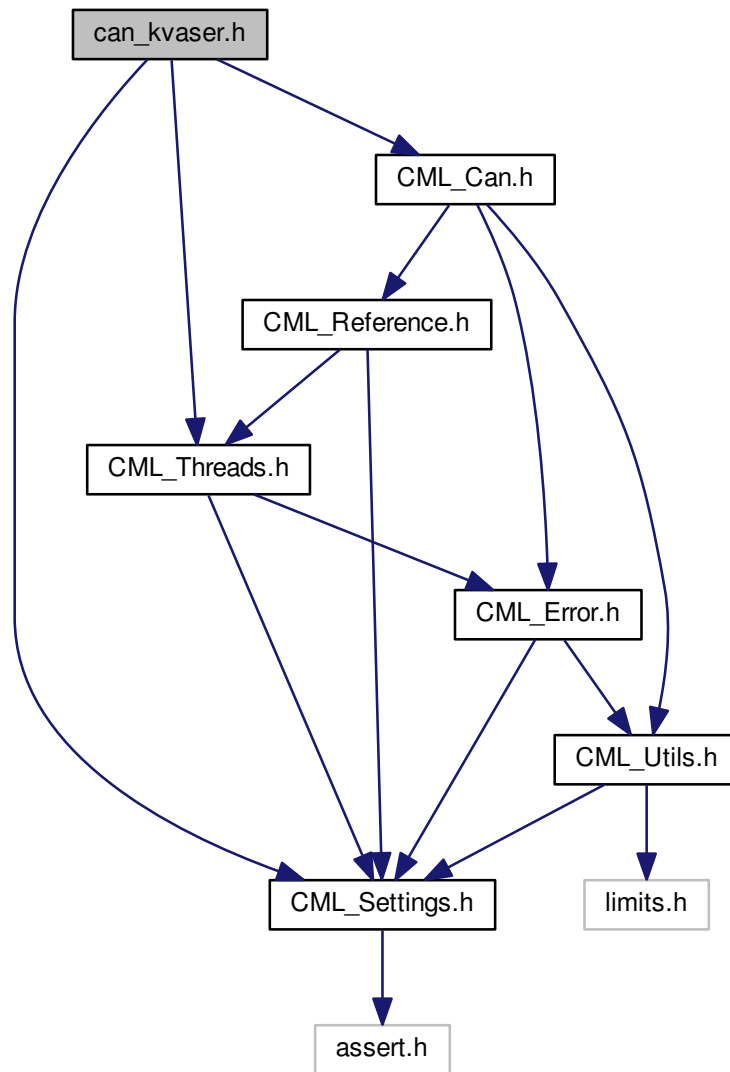

Classes

- class [KvaserCAN](#)
Kvaser specific CAN interface.

6.14.1 Detailed Description

CAN hardware interface for the Kvaser CAN driver.

6.15 CanOpen.cpp File Reference

This file holds code for the top level CANopen class.

Include dependency graph for CanOpen.cpp:

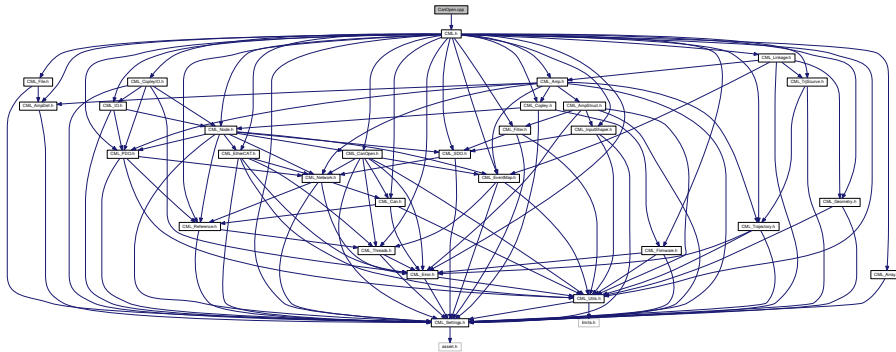

6.15.1 Detailed Description

This file holds code for the top level CANopen class. This class is used for over all control of the CANopen network.

6.16 CML.cpp File Reference

CML object definition.

Include dependency graph for CML.cpp:

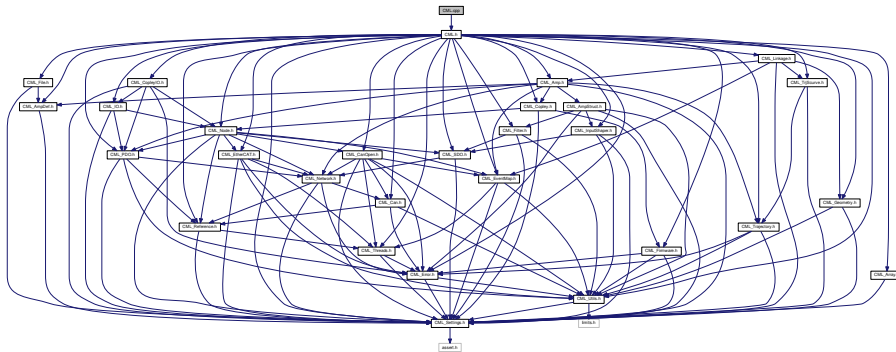

Variables

- [CopleyMotionLibrary cml](#)

Global CML object.

6.16.1 Detailed Description

CML object definition. This file contains the code used to implement the global CML object.

6.17 CML.h File Reference

Top level include file for the CML libraries.

Include dependency graph for CML.h:

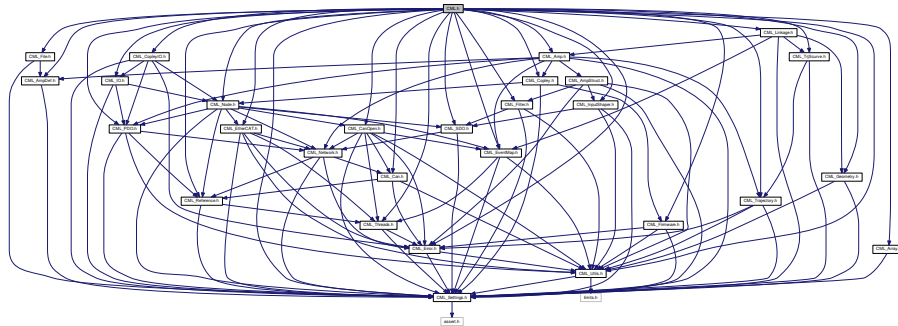

This graph shows which files directly or indirectly include this file:

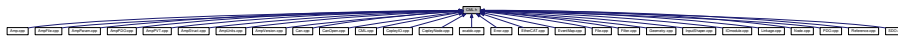

Classes

- class [CopleyMotionLibrary](#)
Copley Motion Libraries utility object.

Enumerations

- enum [CML_LOG_LEVEL](#) {
[LOG_NONE](#) = 0,
[LOG_ERRORS](#) = 1,
[LOG_WARNINGS](#) = 2,
[LOG_DEBUG](#) = 3,
[LOG_FILTER_CAN](#) = 5,
[LOG_CAN](#) = 6,
[LOG_EVERYTHING](#) = 99 }
Copley Motion Libraries debug logging level.

Variables

- [CopleyMotionLibrary cml](#)
Global CML object.

6.17.1 Detailed Description

Top level include file for the CML libraries. This file serves two purposes; it includes all the other CML header files and it defines the CML object. The CML object contains a number of utility methods dealing with the library as a whole.

6.17.2 Enumeration Type Documentation

6.17.2.1 enum CML_LOG_LEVEL

Copley Motion Libraries debug logging level.

The CML libraries may be configured to generate a log file for use in debugging system problems. This feature is turned off by default, but may be enabled by calling the method [CopleyMotionLibrary::SetDebugLevel](#) of the global cml object.

```
cml.SetDebugLevel( LOG_EVERYTHING );
```

This enumeration gives the logging levels that may be passed to the SetDebugLevel function. Debug logging levels are cumulative, so enabling a high level of logging will cause all messages that would have been logged at a lower level to be written to the log as well. For example, setting the log level to LOG_DEBUG will cause all debug messages to be written to the log, as well as all warnings and errors.

Enumerator

LOG_NONE Debug logging is disabled.

LOG_ERRORS Log serious errors only.

LOG_WARNINGS Log warning messages and errors.

LOG_DEBUG Log some debugging info.

LOG_FILT_CAN Log most CAN messages. A few common messages are filtered out.

LOG_CAN Log all CAN messages.

LOG_EVERYTHING Log everything.

6.18 CML_Amp.h File Reference

This file defines the Copley Amplifier object.

Include dependency graph for CML_Amp.h:

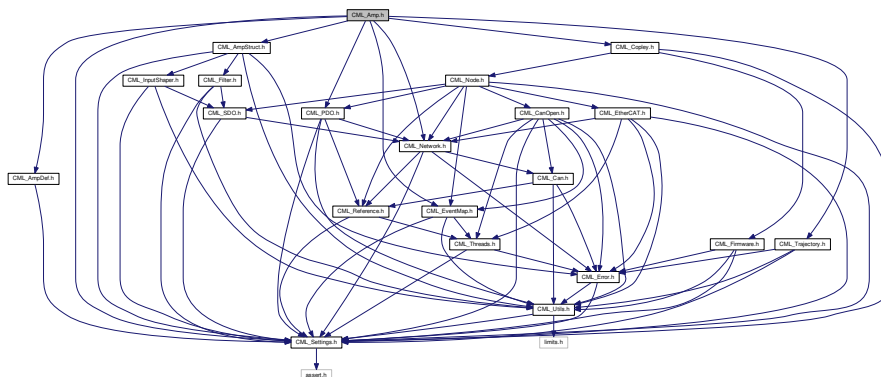

This graph shows which files directly or indirectly include this file:



Classes

- class [AmpError](#)

This class represents error conditions that can occur in the Copley Amplifier object.

- class [AmpFault](#)

This class represents latching amplifier fault conditions.

- class [AmpSettings](#)

Copley amplifier settings object.

- class [PvtSegCache](#)

PVT trajectory segment cache object.

- struct [ProfileConfigTrap](#)

Trapezoidal profile parameters.

- struct [ProfileConfigScurve](#)

S-curve profile parameters.

- struct [ProfileConfigVel](#)

Velocity profile parameters.

- class [Amp](#)

Copley Controls amplifier object.

6.18.1 Detailed Description

This file defines the Copley Amplifier object. This object may be used to interface to an amplifier over the CANopen network.

6.19 CML_AmpDef.h File Reference

Include dependency graph for CML_AmpDef.h:

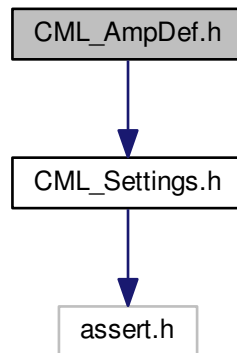

This graph shows which files directly or indirectly include this file:



Enumerations

- enum [AMP_OBJID](#)

This enumeration holds the object identifiers of all of the objects in the amplifier's object dictionary.

- enum [INPUT_PIN_CONFIG](#) {

```

INCFG_NONE = 0x0000,
INCFG_RESET_R = 0x0002,
INCFG_RESET_F = 0x0003,
INCFG_POSLIM_H = 0x0004,
INCFG_POSLIM_L = 0x0005,
INCFG_NEGLIM_H = 0x0006,
INCFG_NEGLIM_L = 0x0007,
INCFG_MOTOR_TEMP_H = 0x0008,
INCFG_MOTOR_TEMP_L = 0x0009,
INCFG_CLR_FAULTS_H = 0x000A,
INCFG_CLR_FAULTS_L = 0x000B,
INCFG_RESET_DISABLE_R = 0x000C,
INCFG_RESET_DISABLE_F = 0x000D,
INCFG_HOME_H = 0x000E,
INCFG_HOME_L = 0x000F,
INCFG_DISABLE_H = 0x0010,
INCFG_DISABLE_L = 0x0011,
INCFG_PWM_SYNC_H = 0x0013,
INCFG_MOTION_ABORT_H = 0x0014,
INCFG_MOTION_ABORT_L = 0x0015,
INCFG_SCALE_ADC_H = 0x0016,
INCFG_SCALE_ADC_L = 0x0017,
INCFG_HIGHSPEED_CAPTURE_R = 0x0018,
INCFG_HIGHSPEED_CAPTURE_F = 0x0019,
INCFG_COUNT_EDGES_R = 0x001A,
INCFG_COUNT_EDGES_F = 0x001B,
INCFG_ENCODER_FAULT_H = 0x001C,
INCFG_ENCODER_FAULT_L = 0x001D,
INCFG_ABORT_WINDOW_R = 0x0024,
INCFG_ABORT_WINDOW_F = 0x0025,
INCFG_HV_LOSS_DISABLE_H = 0x0026,
INCFG_HV_LOSS_DISABLE_L = 0x0027,
INCFG_TRJ_UPDATE_R = 0x0028,
INCFG_TRJ_UPDATE_F = 0x0029,
INCFG_CLR_FAULTS_EVENTS_R = 0x002A,
INCFG_CLR_FAULTS_EVENTS_F = 0x002B,
INCFG_DIS_SIM_ENC_L_BURST_R = 0x002C,
INCFG_DIS_SIM_ENC_H_BURST_F = 0x002D }

```

Input pin configuration settings.

- enum OUTPUT_PIN_CONFIG {
 - OUTCFG_EVENT_STATUS_L = 0x0000,
 - OUTCFG_EVENT_STATUS_H = 0x0100,
 - OUTCFG_EVENT_LATCH_L = 0x0001,
 - OUTCFG_EVENT_LATCH_H = 0x0101,
 - OUTCFG_MANUAL_L = 0x0002,
 - OUTCFG_MANUAL_H = 0x0102,
 - OUTCFG_TRJ_STATUS = 0x0003,
 - OUTCFG_POSITION_WINDOW = 0x0004,
 - OUTCFG_POSITION_TRIG_LOW2HIGH = 0x0005,
 - OUTCFG_POSITION_TRIG_HIGH2LOW = 0x0006,
 - OUTCFG_POSITION_TRIG = 0x0007,
 - OUTCFG_POSITION_TRIG_LIST = 0x0009,
 - OUTCFG_SYNC_OUTPUT = 0x0200,
 - OUTCFG_ACTIVE_HIGH = 0x0100 }

Output pin configuration settings.

- enum AMP_MODE {
AMPMODE_CAN_PROFILE = 0x0001,
AMPMODE_CAN_VELOCITY = 0x0003,
AMPMODE_CAN_TORQUE = 0x0004,
AMPMODE_CAN_HOMING = 0x0006,
AMPMODE_CAN_PVT = 0x0007,
AMPMODE_CAN_SERVO = 0x1E00,
AMPMODE_CAN_USTEP = 0x2800,
AMPMODE_DISABLED = 0x0000,
AMPMODE_PROG_CRNT = 0x0100,
AMPMODE_AIN_CRNT = 0x0200,
AMPMODE_DIN_CRNT = 0x0300,
AMPMODE_FGEN_CRNT = 0x0400,
AMPMODE_PROG_VEL = 0x0B00,
AMPMODE_AIN_VEL = 0x0C00,
AMPMODE_DIN_VEL = 0x0D00,
AMPMODE_FGEN_VEL = 0x0E00,
AMPMODE_DIN_POS = 0x1700,
AMPMODE_FGEN_POS = 0x1800,
AMPMODE_CAM_POS = 0x1900,
AMPMODE_DIN_USTEP = 0x2100,
AMPMODE_FGEN_USTEP = 0x2200,
AMPMODE_DIAG_USTEP = 0x2A00 }

This enumeration is used to specify the mode of operation of the amplifier.

- enum EVENT_STATUS {

```

ESTAT_SHORT_CRCT = 0x00000001,
ESTAT_AMP_TEMP = 0x00000002,
ESTAT_OVER_VOLT = 0x00000004,
ESTAT_UNDER_VOLT = 0x00000008,
ESTAT_MTR_TEMP = 0x00000010,
ESTAT_ENCODER_PWR = 0x00000020,
ESTAT_PHASE_ERR = 0x00000040,
ESTAT_CRNT_LIM = 0x00000080,
ESTAT_VOLT_LIM = 0x00000100,
ESTAT_POSLIM = 0x00000200,
ESTAT_NEGLIM = 0x00000400,
ESTAT_DISABLE_INPUT = 0x00000800,
ESTAT_SOFT_DISABLE = 0x00001000,
ESTAT_STOP = 0x00002000,
ESTAT_BRAKE = 0x00004000,
ESTAT_PWM_DISABLE = 0x00008000,
ESTAT_SOFTLIM_POS = 0x00010000,
ESTAT_SOFTLIM_NEG = 0x00020000,
ESTAT_TRK_ERR = 0x00040000,
ESTAT_TRK_WARN = 0x00080000,
ESTAT_RESET = 0x00100000,
ESTAT_POSWRAP = 0x00200000,
ESTAT_FAULT = 0x00400000,
ESTAT_VEL_LIMIT = 0x00800000,
ESTAT_ACC_LIMIT = 0x01000000,
ESTAT_TRK_WIN = 0x02000000,
ESTAT_HOME = 0x04000000,
ESTAT_MOVING = 0x08000000,
ESTAT_VEL_WIN = 0x10000000,
ESTAT_PHASE_INIT = 0x20000000,
ESTAT_CMD_INPUT = 0x40000000 }

```

Amplifier event status word bit definitions.

- enum AMP_EVENT {

```

AMPEVENT_MOVEDONE = 0x00000001,
AMPEVENT_TRJDONE = 0x00000002,
AMPEVENT_NODEGUARD = 0x00000004,
AMPEVENT_SPACK = 0x00000008,
AMPEVENT_FAULT = 0x00000010,
AMPEVENT_ERROR = 0x00000020,
AMPEVENT_POSWARN = 0x00000040,
AMPEVENT_POSWIN = 0x00000080,
AMPEVENT_VELWIN = 0x00000100,
AMPEVENT_DISABLED = 0x00000200,
AMPEVENT_POSLIM = 0x00000400,
AMPEVENT_NEGLIM = 0x00000800,
AMPEVENT_SOFTLIM_POS = 0x00001000,
AMPEVENT_SOFTLIM_NEG = 0x00002000,
AMPEVENT_QUICKSTOP = 0x00004000,
AMPEVENT_ABORT = 0x00008000,
AMPEVENT_SOFTDISABLE = 0x00010000,
AMPEVENT_HOME_CAPTURE = 0x00020000,
AMPEVENT_PVT_EMPTY = 0x00040000,
AMPEVENT_PHASE_INIT = 0x00080000,
AMPEVENT_NOT_INIT = 0x80000000 }

```

Amplifier events.

- enum `AMP_FAULT` {
 `FAULT_DATAFLASH` = 0x0001,
 `FAULT_ADCOFFSET` = 0x0002,
 `FAULT_SHORT_CRCT` = 0x0004,
 `FAULT_AMP_TEMP` = 0x0008,
 `FAULT_MTR_TEMP` = 0x0010,
 `FAULT_OVER_VOLT` = 0x0020,
 `FAULT_UNDER_VOLT` = 0x0040,
 `FAULT_ENCODER_PWR` = 0x0080,
 `FAULT_PHASE_ERR` = 0x0100,
 `FAULT_TRK_ERR` = 0x0200,
 `FAULT_I2T_ERR` = 0x0400 }

Latching Amplifier faults conditions.

- enum `HALT_MODE` {
 `HALT_DISABLE` = 0,
 `HALT_DECEL` = 1,
 `HALT_QUICKSTOP` = 2,
 `HALT_ABRUPT` = 3 }

The amplifier's halt mode defines it's action when a halt command is issued ([Amp::HaltMove](#)).

- enum `QUICK_STOP_MODE` {
 `QSTOP_DISABLE` = 0,
 `QSTOP_DECEL` = 1,
 `QSTOP_QUICKSTOP` = 2,
 `QSTOP_ABRUPT` = 3,
 `QSTOP_DECEL_HOLD` = 5,
 `QSTOP_QUICKSTOP_HOLD` = 6,
 `QSTOP_ABRUPT_HOLD` = 7 }

The amplifier's quick stop mode defines it's action when a quick stop command is issued ([Amp::QuickStop](#)).

- enum `COPLEY_HOME_METHOD` {

```

CHM_NLIM_ONDX = 1,
CHM_PLIM_ONDX = 2,
CHM_PHOME_ONDX = 3,
CHM_PHOME_INDX = 4,
CHM_NHOME_ONDX = 5,
CHM_NHOME_INDX = 6,
CHM_LHOME_ONDX_POS = 7,
CHM_LHOME_INDX_POS = 8,
CHM_UHOME_INDX_POS = 9,
CHM_UHOME_ONDX_POS = 10,
CHM_UHOME_ONDX_NEG = 11,
CHM_UHOME_INDX_NEG = 12,
CHM_LHOME_INDX_NEG = 13,
CHM_LHOME_ONDX_NEG = 14,
CHM_NLIM = 17,
CHM_PLIM = 18,
CHM_PHOME = 19,
CHM_NHOME = 21,
CHM_LHOME_POS = 23,
CHM_UHOME_POS = 25,
CHM_UHOME_NEG = 27,
CHM_LHOME_NEG = 29,
CHM_NDX_NEG = 33,
CHM_NDX_POS = 34,
CHM_NONE = 35,
CHM_HARDSTOP_POS = 255,
CHM_HARDSTOP_NEG = 254,
CHM_HARDSTOP_ONDX_POS = 253,
CHM_HARDSTOP_ONDX_NEG = 252,
CHM_EXTENDED = 128 }

```

Home methods supported by the Copley amplifier.

- enum PROFILE_TYPE {
PROFILE_VEL = -1,
PROFILE_TRAP = 0,
PROFILE_SCURVE = 3,
PROFILE_CSP = 4 }

Point to point profile types.

- enum AMP_PHASE_MODE {
PHASE_MODE_ENCODER = 0,
PHASE_MODE_TRAP = 1,
PHASE_MODE_NOADJUST = 2,
PHASE_MODE_AHALL90 = 3,
PHASE_MODE_BRUSHED = 4,
PHASE_MODE_NOHALL = 5,
PHASE_MODE_ENCPHASE = 6,
PHASE_MODE_TRAPINTERP = 7 }

Amplifier phasing mode.

- enum AMP_PWM_MODE {
PWM_MODE_STANDARD = 0x0000,
PWM_MODE_FORCECLAMP = 0x0001,
PWM_MODE_AUTOCLAMP = 0x0002,
PWM_MODE_HEXLIMIT = 0x0010 }

Amplifier PWM output mode.

- enum AMP_TRACE_VAR {
TRACEVAR_HIGH_VOLT = 6,
TRACEVAR_TEMP = 37,
TRACEVAR_ANALOG_REF = 5,
TRACEVAR_ENC_SIN = 46,
TRACEVAR_ENC_COS = 47,
TRACEVAR_PHASE = 36,
TRACEVAR_HALLS = 40,
TRACEVAR_INPUTS = 48,
TRACEVAR_RAW_INPUTS = 33,
TRACEVAR_EVENTS = 38,
TRACEVAR_EVENTLATCH = 39,
TRACEVAR_CRNT_A = 3,
TRACEVAR_CRNT_B = 4,
TRACEVAR_CRNT_CMD = 7,
TRACEVAR_CRNT_LIM = 8,
TRACEVAR_CRNT_CMD_D = 9,
TRACEVAR_CRNT_CMD_Q = 10,
TRACEVAR_CRNT_ACT_D = 13,
TRACEVAR_CRNT_ACT_Q = 14,
TRACEVAR_CRNT_ERR_D = 15,
TRACEVAR_CRNT_ERR_Q = 16,
TRACEVAR_VOLT_D = 19,
TRACEVAR_VOLT_Q = 20,
TRACEVAR_VEL_MTR = 23,
TRACEVAR_VEL_RAW = 50,
TRACEVAR_VEL_LOAD = 43,
TRACEVAR_VLOOP_CMD = 24,
TRACEVAR_VLOOP_LIM = 25,
TRACEVAR_VLOOP_ERR = 26,
TRACEVAR_LOAD_POS = 28,
TRACEVAR_MTR_POS = 31,
TRACEVAR_POS_ERR = 30,
TRACEVAR_CMD_POS = 29,
TRACEVAR_CMD_VEL = 44,
TRACEVAR_CMD_ACC = 45,
TRACEVAR_DEST_POS = 49 }

Amplifier trace variables.

- enum AMP_TRACE_STATUS

Amplifier trace status bits.

- enum AMP_TRACE_TRIGGER {

```
TRACETRIG_CHANNEL = 0x000F,  
TRACETRIG_TYPE = 0x0F00,  
TRACETRIG_NONE = 0x0000,  
TRACETRIG_ABOVE = 0x0100,  
TRACETRIG_BELOW = 0x0200,  
TRACETRIG_RISE = 0x0300,  
TRACETRIG_FALL = 0x0400,  
TRACETRIG_BITSET = 0x0500,  
TRACETRIG_BITCLR = 0x0600,  
TRACETRIG_CHANGE = 0x0700,  
TRACETRIG_EVENTSET = 0x0800,  
TRACETRIG_EVENTCLR = 0x0900,  
TRACETRIG_FGEN_CYCLE = 0x0A00,  
TRACETRIG_NODELAY = 0x4000,  
TRACETRIG_SAMPLE = 0x8000 }
```

Amplifier trace trigger settings.

- enum POS_CAPTURE_CFG {
CAPTURE_INDEX_RISING = 0x0001,
CAPTURE_INDEX_FALLING = 0x0002,
CAPTURE_INDEX_LATCH = 0x0004,
CAPTURE_HOME_LATCH = 0x0040,
CAPTURE_HIGH_SPEED_INPUT = 0x0100,
CAPTURE_HIGH_SPEED_INPUT_LATCH = 0x0400 }

Position capture configuration.

- enum POS_CAPTURE_STAT {
CAPTURE_INDEX_FULL = 0x0001,
CAPTURE_INDEX_OVER = 0x0008,
CAPTURE_HOME_FULL = 0x0010,
CAPTURE_HOME_OVER = 0x0080 }

Position capture status register value.

- enum AMP_FEATURE { ,

```

FEATURE_EXTENDED_OUTPUT_PIN_CONFIG,
FEATURE_GEAR_RATIO,
FEATURE_RESOLVER_CYCLES,
FEATURE_HALL_VEL_SHIFT,
FEATURE_PLOOP_SCALE,
FEATURE_STEPPER_CRNT,
FEATURE_CURRENT_SLOPE,
FEATURE_SOFTLIM_ACCEL,
FEATURE_PWMIN_FREQ,
FEATURE_VLOOP_CMD_FILTER,
FEATURE_USTEP_OUTER_LOOP,
FEATURE_STEP_DETENT_GAIN,
FEATURE_USTEP_CONFIG_STATUS,
FEATURE_ALGO_PHASE_INIT_CUR,
FEATURE_ALGO_PHASE_INIT_CONFIG,
FEATURE_CAMMING,
FEATURE_POS_WRAP,
FEATURE_ENC_OPTIONS,
FEATURE_GAIN_SCHED,
FEATURE_PIN_MAP,
FEATURE_CAN_OPTIONS,
FEATURE_CAN_SETTINGS,
FEATURE_AIN_FILTER,
FEATURE_VLOOP_OUT_FILTER,
FEATURE_ILOOP_CMD_FILTER,
FEATURE_PWMIN_MIN_PULSE,
FEATURE_PWMIN_MAX_PULSE,
FEATURE_DA_CONV_CONFIG,
FEATURE_SERVO_CONFIG,
FEATURE_MTR_OVERTEMP,
FEATURE_NET_OPTIONS,
FEATURE_PLOOP_KI,
FEATURE_PLOOP_KD,
FEATURE_VLOOP_CMDFF,
FEATURE_BRAKE_ENABLE_DELAY,
FEATURE_INPUT_SHAPING,
FEATURE_FLOAT_FILTER_COEF,
FEATURE_IO_OPTIONS,
FEATURE_PWMIN_UVCFG,
FEATURE_AXIS_CT }

```

This enumeration is used internally by the amplifier object to check for certain features that are not present in every amp model or firmware version number.

6.19.1 Enumeration Type Documentation

6.19.1.1 enum AMP_EVENT

Amplifier events.

This enumeration provides a list of events that can be used to wait on amplifier conditions.

Enumerator

AMPEVENT_MOVEDONE Set when a move is finished and the amplifier has settled in to position at the end of

the move. Cleared when a new move is started.

AMPEVENT_TRJDONE Set when the trajectory generator finishes a move. The motor may not have settled into position at this point. Cleared when a new move is started.

AMPEVENT_NODEGUARD A node guarding (or heartbeat) error has occurred. This indicates that the amplifier failed to respond within the expected amount of time for either a heartbeat or node guarding message. This could be caused by a network wiring problem, amplifier power down, amp reset, etc. This bit is set when the error occurs, and is cleared by a call to the function [Amp::ClearNodeGuardEvent](#).

AMPEVENT_SPACK This event bit is used internally by the amplifier object. It is set when the amp acknowledges a new move start.

AMPEVENT_FAULT A latching amplifier fault has occurred. The specifics of what caused the fault can be obtained by calling [Amp::GetFaults](#), and the fault conditions can be cleared by calling [Amp::ClearFaults](#).

AMPEVENT_ERROR A non-latching amplifier error has occurred.

AMPEVENT_POSWARN The amplifier's absolute position error is greater than the window set with [Amp::SetPositionWarnWindow](#).

AMPEVENT_POSWIN The amplifier's absolute position error is greater than the window set with [Amp::SetSettlingWindow](#).

AMPEVENT_VELWIN The amplifier's absolute velocity error is greater than the window set with [Amp::SetVelocityWarnWindow](#).

AMPEVENT_DISABLED The amplifier's outputs are disabled. The reason for the disable can be determined by [Amp::GetEventStatus](#)

AMPEVENT_POSLIM The positive limit switch is currently active.

AMPEVENT_NEGLIM The negative limit switch is currently active.

AMPEVENT_SOFTLIM_POS The positive software limit is currently active.

AMPEVENT_SOFTLIM_NEG The negative software limit is currently active.

AMPEVENT_QUICKSTOP The amplifier is presently performing a quick stop sequence.

AMPEVENT_ABORT The last profile was aborted without finishing.

AMPEVENT_SOFTDISABLE The amplifier is software disabled.

AMPEVENT_HOME_CAPTURE A new home position has been captured. Note that this feature requires firmware version ≥ 4.77

AMPEVENT_PVT_EMPTY PVT buffer is empty.

AMPEVENT_PHASE_INIT Amplifier is currently performing a phase initialization.

AMPEVENT_NOT_INIT This amplifier's event mask has not yet been initialized. This event is for internal use only.

6.19.1.2 enum AMP_FAULT

Latching Amplifier faults conditions.

Once a fault is detected in the amplifier, the amp will be disabled until the fault condition has been cleared.

Use [Amp::GetFaults](#) to get a list of any active fault conditions, and [Amp::ClearFaults](#) to clear one or more faults.

Enumerator

FAULT_DATAFLASH Fatal hardware error: the flash data is corrupt.

FAULT_ADCOFFSET Fatal hardware error: An A/D offset error has occurred.

FAULT_SHORT_CRCT The amplifier detected a short circuit condition.

FAULT_AMP_TEMP The amplifier is over temperature.

FAULT_MTR_TEMP A motor temperature error was detected.

FAULT_OVER_VOLT The amplifier bus voltage is over the acceptable limit.

FAULT_UNDER_VOLT The amplifier bus voltage is below the acceptable limit.

FAULT_ENCODER_PWR Over current on the encoder power supply.

FAULT_PHASE_ERR Amplifier phasing error.

FAULT_TRK_ERR Tracking error, the position error is too large.

FAULT_I2T_ERR Current limited by i^2t algorithm.

6.19.1.3 enum AMP_FEATURE

This enumeration is used internally by the amplifier object to check for certain features that are not present in every amp model or firmware version number.

Enumerator

FEATURE_EXTENDED_OUTPUT_PIN_CONFIG Can the amplifier firmware accept more than 6 words of data for its output pin configuration parameter?

FEATURE_GEAR_RATIO Does the amplifier support the gear ratio parameter?

FEATURE_RESOLVER_CYCLES Does the amplifier support the resolver cycles parameter?

FEATURE_HALL_VEL_SHIFT Does the amplifier support the hall velocity shift parameter?

FEATURE_PLOOP_SCALE Does the amplifier support the position loop scaling factor?

FEATURE_STEPPER_CRNT Does the amp support the stepper current parameters (hold current, run to hold time, etc)?

FEATURE_CURRENT_SLOPE Does the amp support the current slope limits?

FEATURE_SOFTLIM_ACCEL Does the amp support the software limit acceleration parameter?

FEATURE_PWMIN_FREQ Does the amp support the pwm input frequency parameter?

FEATURE_VLOOP_CMD_FILT Does the amp support the velocity loop command filter?

FEATURE_USTEP_OUTER_LOOP Does the amp support ustep outer loop.

FEATURE_STEP_DETENT_GAIN Does the amp support ustep Detent gain correction factor.

FEATURE_USTEP_CONFIG_STATUS Does the amp support ustep Stepper config and status.

FEATURE_ALGO_PHASE_INIT_CUR Does the amp support algorithmic phase init max current and time settings.

FEATURE_ALGO_PHASE_INIT_CONFIG Does the amp support algorithmic phase init config.

FEATURE_CAMMING Does the amp support camming.

FEATURE_POS_WRAP Does the amp support position wrap.

FEATURE_ENC_OPTIONS Does the amp support encoder options.

FEATURE_GAIN_SCHED Does the amp support gain scheduling.

FEATURE_PIN_MAP Does the amp support input pin mapping.

FEATURE_CAN_OPTIONS Does the amp support can option.

FEATURE_CAN_SETTINGS Does the amp support can option.

FEATURE_AIN_FILT Does the amp support analog reference input filter.

FEATURE_VLOOP_OUT_FILT Does the amp support the velocity loop cmd filter.

FEATURE_ILOOP_CMD_FILT Does the amp support the current loop cmd filter.

FEATURE_PWMIN_MIN_PULSE Does the amp support configuring the min pwm pulse width.

- FEATURE_PWMIN_MAX_PULSE** Does the amp support configuring the max pwm pulse width.
- FEATURE_DA_CONV_CONFIG** Does the amp support DA configuration.
- FEATURE_SERVO_CONFIG** Does the amp support advanced servo loop configurations.
- FEATURE_MTR_OVERTEMP** Does the amp support analog mtr over temp.
- FEATURE_NET_OPTIONS** Does the amp support configuring the network.
- FEATURE_PLOOP_KI** Does the amp support the position loop Ki param.
- FEATURE_PLOOP_KD** Does the amp support the position loop Kd param.
- FEATURE_VLOOP_CMDFF** Does the amp support the velocity loop command feed forward.
- FEATURE_BRAKE_ENABLE_DELAY** Does the amp support motor brake enable delay time.
- FEATURE_INPUT_SHAPING** Does the amp support input shaping.
- FEATURE_FLOAT_FILT_COEF** Are filter coefficients stored at floating point values?
- FEATURE_IO_OPTIONS** Does the amp support IO configuration.
- FEATURE_PWMIN_UVCFG** Does the amp support the UV config in UV mode?
- FEATURE_AXIS_CT** Does the amp support the paramter containing the number of axis?

6.19.1.4 enum AMP_MODE

This enumeration is used to specify the mode of operation of the amplifier.

The amplifier mode of operation specifies the control method to be used by the amplifier, as well as the source of input to that control structure.

The amplifier can be controlled in servo mode or in microstepping mode. When running in servo mode the amplifier uses up to three nested control loops. These loops control current, velocity and position. In microstepping mode the low level current loop is retained, but the upper level loops are replaced with a simple position command.

The command source of the amplifier will normally be the CANopen network itself. However, the amplifier also supports several low level control methods in which commands are received through analog or digital input pins, or even from an internal function generator.

Normally, only the CANopen modes of operation will be used when running over the CANopen network. These modes are AMPMODE_CAN_PROFILE, AMPMODE_CAN_VELOCITY, AMPMODE_CAN_HOMING, and AMPMODE_CAN_PVT. Each of these modes can be used on either servo or microstepping drives. It's typically not necessary to specify the type of control method (servo or microstepping) to be used with these modes as it can be determined by the type of amplifier being used. Servo amplifier's (such as Accelnet) default to servo mode, and microstepping amplifiers (such as Stepnet) will default to microstepping mode. If this default is not appropriate for the application, then the control method may be forced by ORing in one of the following two values; AMPMODE_CAN_SERVO and AMPMODE_CAN_USTEP.

Enumerator

AMPMODE_CAN_PROFILE In this mode the CANopen network sends move commands to the amplifier, and the amplifier uses it's internal trajectory generator to perform the moves. This mode conforms to the CANopen device profile for motion control (DSP-402) profile position mode.

AMPMODE_CAN_VELOCITY In this mode the CANopen network commands target velocity values to the amplifier. The amplifier uses it's programmed acceleration and deceleration values to ramp the velocity up/down to the target.

Note that support for profile velocity mode was added in amplifier firmware version 3.06. Earlier versions of firmware will report an error if this mode is selected.

AMPMODE_CAN_TORQUE In this mode the CANopen network commands torque values to the amplifier. Note that support for profile torque mode was added in amplifier firmware version 3.34. Earlier versions of firmware will report an error if this mode is selected.

- AMPMODE_CAN_HOMING** This mode is used to home the motor (i.e. find the motor zero position) under the control of the CANopen network. This mode conforms to the CANopen device profile for motion control (DS-P-402) homing mode.
- AMPMODE_CAN_PVT** In this mode the CANopen master calculates the motor trajectory and streams it over the CANopen network as a set of points that the amplifier interpolated between. This mode conforms to the CANopen device profile for motion control (DSP-402) interpolated position mode.
- AMPMODE_CAN_SERVO** This value may be combined with one of the standard CAN control modes to specify that servo control should be used. This is most often specified when a microstepping amplifier (such as the Stepnet) is to be used in servo mode.
- AMPMODE_CAN_USTEP** This value may be combined with one of the standard CAN control modes to specify that microstepping control should be used. This is most often specified when a servo amplifier (such as the Accelnet) is to be used in microstepping mode.
- AMPMODE_DISABLED** Disable the amplifier. In this mode, none of the controls loops are running, and no voltage will be applied across the motor windings.
- AMPMODE_PROG_CRNT** Current mode in which the command to the current loop is simply a static value that may be programmed over the serial port or CANopen network. The programmed current value can be set with the function [Amp::SetCurrentProgrammed](#)
- AMPMODE_AIN_CRNT** Current mode in which the command to the current loop is derived from the analog input. Note that some amplifier models do not support an analog input. Please refer to the amplifier datasheet to determine if this mode is applicable.
- AMPMODE_DIN_CRNT** Current mode in which the command to the current loop is derived from the digital input pins. One or two of the digital inputs are used as a PWM input command which is interpreted as a current command. Please refer to the amplifier data sheet to determine which input(s) should be used in this mode.
- AMPMODE_FGEN_CRNT** Current mode in which the command to the current loop is derived from the internal function generator.
- AMPMODE_PROG_VEL** Velocity mode in which the command to the velocity loop is simply a static value that may be programmed over the serial or CANopen network. The programmed velocity value can be set with the function [Amp::SetVelocityProgrammed](#)
- AMPMODE_AIN_VEL** Velocity mode in which the command to the velocity loop is derived from the analog input. Note that some amplifier models do not support an analog input. Please refer to the amplifier datasheet to determine if this mode is applicable.
- AMPMODE_DIN_VEL** Velocity mode in which the command to the velocity loop is derived from the digital input pins. One or two of the digital inputs are used as a PWM input command which is interpreted as a velocity command. Please refer to the amplifier data sheet to determine which input(s) should be used in this mode.
- AMPMODE_FGEN_VEL** Velocity mode in which the command to the velocity loop is derived from the internal function generator.
- AMPMODE_DIN_POS** Position mode in which the command to the position loop is derived from the digital input pins. Two of the digital inputs can be configured as either a master encoder input (quadrature input), a step & direction input, or a step up / step down input. Please refer to the amplifier data sheet to determine which inputs should be used in this mode.
- AMPMODE_FGEN_POS** Position mode in which the command to the position loop is derived from the internal function generator.
- AMPMODE_CAM_POS** Position mode in which the command to the position loop is derived from CAM tables located in the amplifiers memory.
- AMPMODE_DIN_USTEP** Microstepping mode in which the commanded position is derived from the digital input pins. Two of the digital inputs can be configured as either a master encoder input (quadrature input), a step & direction input, or a step up / step down input. Please refer to the amplifier data sheet to determine which inputs should be used in this mode.
- AMPMODE_FGEN_USTEP** Microstepping mode in which the commanded position is derived from the internal function generator.

AMPMODE_DIAG_USTEP Diagnostic microstepping mode. This is a very simple microstepping mode that can be used for motor setup and testing. A constant motor current is set by the programmed current value, and the motor phase is microstepped at a fixed rate. The position and velocity loops are not used in this mode.

6.19.1.5 enum AMP_PHASE_MODE

Amplifier phasing mode.

This enumeration gives the legal values for the amplifier phasing mode setting. The phasing mode controls what type of input the amplifier uses to determine the phase angle when commutating a brushless DC motor.

Enumerator

PHASE_MODE_ENCODER Use a combination of hall sensors and encoder input. The hall sensors are used at startup, and will be used to constantly adjust the phase angle on every hall transition. This is the default phase mode, and should be used when both hall sensors and encoder input are present.

PHASE_MODE_TRAP Phase using only the hall sensor inputs. This mode gives rougher operation than the encoder based mode, however it can be used when no encoder input is available.

PHASE_MODE_NOADJUST Use both encoder & hall inputs, but only use the hall inputs on startup and ignore them after that. This mode should normally not be used unless there is a good reason to ignore the hall inputs after startup.

PHASE_MODE_AHALL90 Use analog hall inputs offset at 90 deg connected to the encoder sine / cosine inputs.

PHASE_MODE_BRUSHED This phase mode is used to force brushed DC motor output. It should only be used when the amplifier is connected to a brushed DC motor. NOTE - this mode is obsolete. The motor type parameter (object 0x2383) should now be used to indicate a brush motor which will force the correct commutation mode.

PHASE_MODE_NOHALL Phase using the encoder only. In this mode, the amplifier will use an algorithmic phase initialization on startup. This mode can be used when an encoder is present, but no halls are available.

PHASE_MODE_ENCPHASE Use phase information obtained from the encoder. This mode is used with resolvers and most absolute encoders which are able to communicate phasing information along with the position.

PHASE_MODE_TRAPINTERP Use interpolated trapezoidal commutation. This mode can be used when digital hall sensors are available on the motor. At high speeds the amp interpolates between the hall sensor angles and creates a smoother commutation angle.

6.19.1.6 enum AMP_PWM_MODE

Amplifier PWM output mode.

This enumeration gives the legal values for setting up the amplifier's PWM output mode. The PWM output mode controls some details of how the amplifier drives its PWM outputs.

Enumerator

PWM_MODE_STANDARD Standard PWM mode. This mode should be selected for most applications.

PWM_MODE_FORCECLAMP This bit forces the amplifier into PWM bus clamping mode. Bus clamping mode is a different method of driving the PWM outputs. It can produce less switching loss at the expense of greater cross over distortion.

PWM_MODE_AUTOCLAMP Automatically switch between bus clamping and normal output mode based on the PWM duty cycle. Bus clamping mode is used at high duty cycles, normal mode is used at low duty cycles.

PWM_MODE_HEXLIMIT If this bit is set, the amplifier's output voltage is limited using a method known as hexagonal limiting. If this bit is clear, circular limiting is used. Hexagonal limiting gives the maximum voltage output at the expense of some added torque ripple. Higher top speeds may be attained using hexagonal limiting.

6.19.1.7 enum AMP_TRACE_STATUS

Amplifier trace status bits.

The amplifier's trace mechanism reports it's status as a collection of these bits.

6.19.1.8 enum AMP_TRACE_TRIGGER

Amplifier trace trigger settings.

Enumerator

TRACETRIG_CHANNEL These bits define which of the trace channels to use for triggering. Not all trigger types require a trace channel, for those this value is ignored.

TRACETRIG_TYPE These bits define the trace trigger type to use.

TRACETRIG_NONE Trace trigger type none. The trace is triggered immediately on start.

TRACETRIG_ABOVE Trigger as soon as the value on the selected variable is above the trigger level.

TRACETRIG_BELOW Trigger as soon as the value on the selected variable is below the trigger level.

TRACETRIG_RISE Trigger when the value on the selected variable changes from below the trigger level to above it.

TRACETRIG_FALL Trigger when the value on the selected variable changes from above the trigger level to below it.

TRACETRIG_BITSET Treat the trigger level as a bit mask which selects one or more bits on the selected trace variable. The trigger occurs as soon as any of the selected bits are set.

TRACETRIG_BITCLR Treat the trigger level as a bit mask which selects one or more bits on the selected trace variable. The trigger occurs as soon as any of the selected bits are clear.

TRACETRIG_CHANGE Trigger any time the selected trace variable value changes.

TRACETRIG_EVENTSET Treat the trigger level as a bit mask which selects one or more bits on the amplifier's event status register. The trigger occurs as any of the selected bits are set. Note that this trigger type does not use a trace variable.

TRACETRIG_EVENTCLR Treat the trigger level as a bit mask which selects one or more bits on the amplifier's event status register. The trigger occurs as any of the selected bits are clear. Note that this trigger type does not use a trace variable.

TRACETRIG_FGEN_CYCLE Trigger at the start of the next function generator cycle. This trigger type is only useful when running in function generator mode. It does not use a trace variable or the trigger level.

TRACETRIG_NODELAY If this bit is set, then the trigger is allowed to occur even if the trace setup delay has not yet occurred. Normally, if a negative trace delay is set then that much time must expire after the trace has been started before a trigger will be recognized. If this bit is set, the trigger will be recognized even if the setup delay hasn't been met.

TRACETRIG_SAMPLE Only take a single sample for each trigger. Normally, the occurrence of the trigger causes the trace to begin sampling data and stop when the trace buffer is full. If this bit is set, each trigger occurrence will cause a single sample of trace data.

6.19.1.9 enum AMP_TRACE_VAR

Amplifier trace variables.

This enumeration lists the amplifier variables that are available for use with the amplifier's internal trace routine.

Enumerator

- TRACEVAR_HIGH_VOLT** High voltage bus.
- TRACEVAR_TEMP** Amplifier temperature.
- TRACEVAR_ANALOG_REF** Analog reference input.
- TRACEVAR_ENC_SIN** Analog encoder sine.
- TRACEVAR_ENC_COS** Analog encoder cosine.
- TRACEVAR_PHASE** Motor phase angle.
- TRACEVAR_HALLS** Hall sensor state.
- TRACEVAR_INPUTS** digital input pins (after deadtime)
- TRACEVAR_RAW_INPUTS** digital input pins (before deadtime)
- TRACEVAR_EVENTS** [Event](#) status register.
- TRACEVAR_EVENTLATCH** Latched version of event status register.
- TRACEVAR_CRNT_A** Actual current, current sensor A.
- TRACEVAR_CRNT_B** Actual current, current sensor B.
- TRACEVAR_CRNT_CMD** Commanded current (before limiting)
- TRACEVAR_CRNT_LIM** Commanded current (after limiting)
- TRACEVAR_CRNT_CMD_D** Commanded current, D axis.
- TRACEVAR_CRNT_CMD_Q** Commanded current, Q axis.
- TRACEVAR_CRNT_ACT_D** Actual current, calculated for D axis.
- TRACEVAR_CRNT_ACT_Q** Actual current, calculated for Q axis.
- TRACEVAR_CRNT_ERR_D** Current loop error, D axis.
- TRACEVAR_CRNT_ERR_Q** Current loop error, Q axis.
- TRACEVAR_VOLT_D** Current loop output voltage, D axis.
- TRACEVAR_VOLT_Q** Current loop output voltage, Q axis.
- TRACEVAR_VEL_MTR** Motor velocity with some filtering.
- TRACEVAR_VEL_RAW** Motor velocity, unfiltered.
- TRACEVAR_VEL_LOAD** Load encoder velocity.
- TRACEVAR_VLOOP_CMD** Velocity loop commanded velocity (before limiting)
- TRACEVAR_VLOOP_LIM** Velocity loop commanded velocity (after limiting)
- TRACEVAR_VLOOP_ERR** Velocity loop error.
- TRACEVAR_LOAD_POS** Load encoder position.
- TRACEVAR_MTR_POS** Motor encoder position.
- TRACEVAR_POS_ERR** Position error.
- TRACEVAR_CMD_POS** Commanded position from trajectory generator.
- TRACEVAR_CMD_VEL** Commanded velocity from trajectory generator.
- TRACEVAR_CMD_ACC** Commanded acceleration from trajectory generator.
- TRACEVAR_DEST_POS** Destination position.

6.19.1.10 enum COPLEY_HOME_METHOD

Home methods supported by the Copley amplifier.

This enumeration gives more useful names to the various homing methods currently supported by the Copley amplifier.

The names of the members of this enumeration define the type of homing procedure. These names are made up of the following elements:

1. CHM: prefix that identifies the member as a Copley Home Method
2. Sensor: Defines the type of sensor that defines the location of the home position. It will be one of the following:
 - PLIM: A positive limit switch
 - NLIM: A negative limit switch
 - PHOME: A positive home switch. This is a home switch that goes active at some point, and remains active for all greater positions.
 - NHOME: A negative home switch. This is a home switch that goes active at some point, and remains active for all lower positions.
 - LHOME: The lower side of a momentary home switch. This type of home switch has an active region and is inactive on either side of that region. This choice selects the lower edge of that switch.
 - UHOME: The upper side of a momentary home switch. This type of home switch has an active region and is inactive on either side of that region. This choice selects the upper edge of that switch.
3. Index: This defines whether an encoder index pulse will be used to mark the exact home location in conjunction with the sensor. If so, it identifies which index position will be used. It will be one of the following:
 - none: If not specified, then no index is used. The edge of the sensor will define the home position.
 - ONDX: Outer index switch. This is an index on the inactive side of the sensor
 - INDX: Inner index switch. This is the first index on the active side of the sensor.
4. Initial move direction: For some home methods, this is provided and defines the initial move direction. The initial move direction is only specified if it isn't already obvious based on the home type.
 - none: The initial move direction is always obvious and does not need to be specified.
 - NEG: Move in the negative direction if the home position is not obvious. If the negative limit switch is encountered before the home region is found, then the move direction will be reversed.
 - POS: Move in the positive direction if the home position is not obvious. If the positive limit switch is encountered before the home region is found, then the move direction will be reversed.

Enumerator

CHM_NLIM_ONDX Move into the negative limit switch, then back out to the first encoder index pulse beyond it. The index position is home.

CHM_PLIM_ONDX Move into the positive limit switch, then back out to the first encoder index pulse beyond it. The index position is home.

CHM_PHOME_ONDX Move to a positive home switch, then back out of it to the first encoder index outside the home region. The index position is home.

CHM_PHOME_INDX Move to a positive home switch, and continue into it to the first encoder index inside the home region. The index position is home.

CHM_NHOME_ONDX Move to a negative home switch, then back out of it to the first encoder index outside the home region. The index position is home.

CHM_NHOME_INDX Move to a negative home switch, and continue into it to the first encoder index inside the home region. The index position is home.

- CHM_LHOME_ONDX_POS** Move to the lower side of a momentary home switch. Then find the first encoder index pulse outside the home region. If the home switch is not active when the home sequence starts, then the initial move will be positive.
- CHM_LHOME_INDX_POS** Move to the lower side of a momentary home switch. Then find the first encoder index pulse inside the home region. If the home switch is not active when the home sequence starts, then the initial move will be positive.
- CHM_UHOME_INDX_POS** Move to the upper side of a momentary home switch. Then find the first encoder index pulse inside the home region. If the home switch is not active when the home sequence starts, then the initial move will be positive.
- CHM_UHOME_ONDX_POS** Move to the upper side of a momentary home switch. Then find the first encoder index pulse outside the home region. If the home switch is not active when the home sequence starts, then the initial move will be positive.
- CHM_UHOME_ONDX_NEG** Move to the upper side of a momentary home switch. Then find the first encoder index pulse outside the home region. If the home switch is not active when the home sequence starts, then the initial move will be negative.
- CHM_UHOME_INDX_NEG** Move to the upper side of a momentary home switch. Then find the first encoder index pulse inside the home region. If the home switch is not active when the home sequence starts, then the initial move will be negative.
- CHM_LHOME_INDX_NEG** Move to the lower side of a momentary home switch. Then find the first encoder index pulse inside the home region. If the home switch is not active when the home sequence starts, then the initial move will be negative.
- CHM_LHOME_ONDX_NEG** Move to the lower side of a momentary home switch. Then find the first encoder index pulse outside the home region. If the home switch is not active when the home sequence starts, then the initial move will be negative.
- CHM_NLIM** Move into the negative limit switch. The edge of the limit is home.
- CHM_PLIM** Move into the positive limit switch. The edge of the limit is home.
- CHM_PHOME** Move to a positive home switch. The edge of the home region is home.
- CHM_NHOME** Move to a negative home switch. The edge of the home region is home.
- CHM_LHOME_POS** Move to the lower side of a momentary home switch. The edge of the home region is home. If the home switch is not active when the home sequence starts, then the initial move will be positive.
- CHM_UHOME_POS** Move to the upper side of a momentary home switch. The edge of the home region is home. If the home switch is not active when the home sequence starts, then the initial move will be positive.
- CHM_UHOME_NEG** Move to the upper side of a momentary home switch. The edge of the home region is home. If the home switch is not active when the home sequence starts, then the initial move will be negative.
- CHM_LHOME_NEG** Move to the lower side of a momentary home switch. The edge of the home region is home. If the home switch is not active when the home sequence starts, then the initial move will be negative.
- CHM_NDX_NEG** Move in the negative direction until the first encoder index pulse is found. The index position is home.
- CHM_NDX_POS** Move in the positive direction until the first encoder index pulse is found. The index position is home.
- CHM_NONE** Set the current position to home.
- CHM_HARDSTOP_POS** Home to a hard stop. The motor will start running in the positive direction until the homing current has been reached. It will hold this current until the homing delay has expired. The actual position after that delay is home.
- CHM_HARDSTOP_NEG** Home to a hard stop. The motor will start running in the negative direction until the homing current has been reached. It will hold this current until the homing delay has expired. The actual position after that delay is home.

CHM_HARDSTOP_ONDX_POS Home to a hard stop. The motor will start running in the positive direction until the homing current has been reached. It will hold this current until the homing delay has expired. It will then move away from the hard stop until an index mark is located. The index position is home.

CHM_HARDSTOP_ONDX_NEG Home to a hard stop. The motor will start running in the negative direction until the homing current has been reached. It will hold this current until the homing delay has expired. It will then move away from the hard stop until an index mark is located. The index position is home.

CHM_EXTENDED Home using an extended home method. This is not a real home method, but instead a flag that is used by the [Amp::GoHome](#) function to indicate that a non-standard homing method is to be used. When this value is passed it instructs the GoHome function to execute the home sequence through the use of a special low-level homing parameter implemented in the amplifier firmware. This allows a bit more flexibility on the home sequencer.

6.19.1.11 enum EVENT_STATUS

Amplifier event status word bit definitions.

Enumerator

ESTAT_SHORT_CRCT Amplifier short circuit.

ESTAT_AMP_TEMP Amplifier over temperature.

ESTAT_OVER_VOLT Amplifier over voltage.

ESTAT_UNDER_VOLT Amplifier under voltage.

ESTAT_MTR_TEMP Motor over temperature.

ESTAT_ENCODER_PWR Encoder power error.

ESTAT_PHASE_ERR Phasing error.

ESTAT_CRNT_LIM Current limited.

ESTAT_VOLT_LIM Voltage limited.

ESTAT_POSLIM Positive limit switch triggered.

ESTAT_NEGLIM Negative limit switch triggered.

ESTAT_DISABLE_INPUT Enable input pin not set.

ESTAT_SOFT_DISABLE Disabled due to software request.

ESTAT_STOP Try to stop motor (after disable, before brake)

ESTAT_BRAKE Brake actuated.

ESTAT_PWM_DISABLE PWM outputs disabled.

ESTAT_SOFTLIM_POS Positive software limit reached.

ESTAT_SOFTLIM_NEG Negative software limit reached.

ESTAT_TRK_ERR Tracking error.

ESTAT_TRK_WARN Tracking warning.

ESTAT_RESET Amplifier has been reset.

ESTAT_POSWRAP Encoder position wrapped (rotary) or hit limit (linear).

ESTAT_FAULT Latching fault in effect.

ESTAT_VEL_LIMIT Velocity is at limit.

ESTAT_ACC_LIMIT Acceleration is at limit.

ESTAT_TRK_WIN Not in tracking window if set.

- ESTAT_HOME** Home switch is active.
- ESTAT_MOVING** [Trajectory](#) generator active OR not yet settled.
- ESTAT_VEL_WIN** Velocity error outside of velocity window when set.
- ESTAT_PHASE_INIT** Set when using algorithmic phase init mode & phase not initialized.
- ESTAT_CMD_INPUT** Command input fault is active.

6.19.1.12 enum HALT_MODE

The amplifier's halt mode defines its action when a halt command is issued ([Amp::HaltMove](#)).

When the halt command is issued, the move in progress will be terminated using the method defined in this mode. Unless the HALT_DISABLE method is selected, the amplifier will remain enabled and holding position at the end of the halt sequence.

Enumerator

- HALT_DISABLE** Disable the amplifier immediately.
- HALT_DECEL** Slow down using the profile deceleration.
- HALT_QUICKSTOP** Slow down using the quick stop deceleration.
- HALT_ABRUPT** Slow down with unlimited deceleration.

6.19.1.13 enum INPUT_PIN_CONFIG

Input pin configuration settings.

The digital input pins located on an amplifier can be programmed to perform some action. This enumeration provides a list of the possible settings for an input pin.

Note that it is perfectly legal to program more than one input pin to perform the same action. It's often useful to have two hardware disable inputs for example. If either of these inputs becomes active, the amplifier will be disabled.

Note: Bits 12-13 of the input config specify the axis the input configuration will be applied to.

Whether the inputs are configured to perform some action or not, it's still possible to read them directly using the [Amp::GetInputs](#) function.

Enumerator

- INCFG_NONE** No function assigned to the input.
- INCFG_RESET_R** Reset the amplifier on the Rising edge of the input.
- INCFG_RESET_F** Reset the amplifier on the Falling edge of the input.
- INCFG_POSLIM_H** Positive limit switch, active High.
- INCFG_POSLIM_L** Positive limit switch, active Low.
- INCFG_NEGLIM_H** Negative limit switch, active High.
- INCFG_NEGLIM_L** Negative limit switch, active Low.
- INCFG_MOTOR_TEMP_H** Motor temp sensor active high.
- INCFG_MOTOR_TEMP_L** Motor temp sensor active low.
- INCFG_CLR_FAULTS_H** Clear faults on edge, disable while high.
- INCFG_CLR_FAULTS_L** Clear faults on edge, disable while low.
- INCFG_RESET_DISABLE_R** Reset on rising edge, disable while high.

INCFG_RESET_DISABLE_F Reset on falling edge, disable while low.

INCFG_HOME_H Home switch, active high.

INCFG_HOME_L Home switch, active low.

INCFG_DISABLE_H Amplifier disable active high.

INCFG_DISABLE_L Amplifier disable active low.

INCFG_PWM_SYNC_H Sync input on falling edge, valid only on high speed inputs.

INCFG_MOTION_ABORT_H Abort motion active high.

INCFG_MOTION_ABORT_L Abort motion active low.

INCFG_SCALE_ADC_H Scale analog reference input by a factor of 8 when high.

INCFG_SCALE_ADC_L Scale analog reference input by a factor of 8 when low.

INCFG_HIGHSPEED_CAPTURE_R High speed position capture on rising edge.

INCFG_HIGHSPEED_CAPTURE_F High speed position capture on falling edge.

INCFG_COUNT_EDGES_R Count rising edges of input, store the results to an indexer register.

INCFG_COUNT_EDGES_F Count falling edges of input, store the results to an indexer register.

INCFG_ENCODER_FAULT_H Encoder fault input, active high.

INCFG_ENCODER_FAULT_L Encoder fault input, active low.

INCFG_ABORT_WINDOW_R Abort move on rising edge if not within N counts of destination position.

INCFG_ABORT_WINDOW_F Abort move on falling edge if not within N counts of destination position.

INCFG_HV_LOSS_DISABLE_H Mark HV loss on rising edge, disable while high.

INCFG_HV_LOSS_DISABLE_L Mark HV loss on falling edge, disable while low.

INCFG_TRJ_UPDATE_R [Trajectory](#) update on rising edge.

INCFG_TRJ_UPDATE_F [Trajectory](#) update on falling edge.

INCFG_CLR_FAULTS_EVENTS_R Clear faults and event latch on rising edge.

INCFG_CLR_FAULTS_EVENTS_F Clear faults and event latch on falling edge.

INCFG_DIS_SIM_ENC_L_BURST_R Disable simulated encoder output when low. Burst current position on encoder output on rising edge.

INCFG_DIS_SIM_ENC_H_BURST_F Disable simulated encoder output when high. Burst current position on encoder output on falling edge.

6.19.1.14 enum OUTPUT_PIN_CONFIG

Output pin configuration settings.

The digital output pins located on the amplifier can be programmed to follow one or more bits in one of the amplifier's status words.

This enumeration is used to specify which status word a particular output pin will follow, and whether the output will be active high or active low.

Each output pin has a configuration value associated with it (which should be programmed using one of the values of this enumeration), and a 32-bit mask value. If the output pin is configured to follow a status register, the mask identifies which bit(s) of the status register should be used to control the output pin. If any of the masked bits in the status register are set, then the output pin will go active.

Enumerator

OUTCFG_EVENT_STATUS_L The output pin follows the amplifier's event status register and is active Low.

- OUTCFG_EVENT_STATUS_H** The output pin follows the amplifier's event status register and is active High.
- OUTCFG_EVENT_LATCH_L** The output pin follows the latched version of the amplifier's event status register and is active Low.
- OUTCFG_EVENT_LATCH_H** The output pin follows the latched version of the amplifier's event status register and is active High.
- OUTCFG_MANUAL_L** The output pin is manually controlled using the [Amp::SetOutputs](#) function, and the output is active Low.
- OUTCFG_MANUAL_H** The output pin is manually controlled using the [Amp::SetOutputs](#) function, and the output is active High.
- OUTCFG_TRJ_STATUS** The output pin follows bits in the trajectory status register.
- OUTCFG_POSITION_WINDOW** The output pin will go active when the actual motor position is greater than the first output parameter, and less than the second output parameter.
- OUTCFG_POSITION_TRIG_LOW2HIGH** The output pin will go active when the motor actual position crosses through a programmed value in the low to high direction. The pin will stay active for a programmed amount of time. The first output parameter specifies the position, and the second output parameter specifies the time to remain active in milliseconds.
- OUTCFG_POSITION_TRIG_HIGH2LOW** The output pin will go active when the motor actual position crosses through a programmed value in the high to low direction. The pin will stay active for a programmed amount of time. The first output parameter specifies the position, and the second output parameter specifies the time to remain active in milliseconds.
- OUTCFG_POSITION_TRIG** The output pin will go active when the motor actual position crosses through a programmed value in either direction. The pin will stay active for a programmed amount of time. The first output parameter specifies the position, and the second output parameter specifies the time to remain active in milliseconds.
- OUTCFG_POSITION_TRIG_LIST** The output pin will go active when the motor actual position crosses through any one of a series of programmed values in either direction. The pin will stay active for a programmed amount of time. The list of output positions to trigger on must be uploaded into an area of trace memory. The first output parameter gives a 16-bit word offset into trace memory in its upper half, and the number of positions in its lower half. The second parameter specifies the time to remain active in milliseconds.
- OUTCFG_SYNC_OUTPUT** If set the output pin is used as Sync output. This bit can only be used with output pin 0.
- OUTCFG_ACTIVE_HIGH** This bit may be ORed with any of the other output pin configuration values to make them active high.

6.19.1.15 enum POS_CAPTURE_CFG

Position capture configuration.

The amplifier is able to capture the encoder position on one of two events; either the encoder index signal, or a general purpose input pin which has been configured as a home switch.

This enumeration gives the values that may be used to configure this capture mechanism using the [Amp::SetPosCapture-Cfg](#) method.

Enumerator

- CAPTURE_INDEX_RISING** If this bit is set, the rising edge of the encoder index signal will be used to capture the index position.
- CAPTURE_INDEX_FALLING** If this bit is set, the falling edge of the encoder index signal will be used to capture the index position.

CAPTURE_INDEX_LATCH If this bit is set, then index capture values will not be overwritten if a new index edge is received before the previously captured value has been read.

CAPTURE_HOME_LATCH If this bit is set, then captured home sensor positions will not be overwritten if a new home input edge is received before the previous captured value was read.

CAPTURE_HIGH_SPEED_INPUT If this bit is set, then the high speed input based position capture is enabled. Note that this features requires firmware versions ≥ 5.12 to work.

CAPTURE_HIGH_SPEED_INPUT_LATCH If this bit is set, then captured high speed input positions will not be overwritten if a new input is received before the previous position was read.

6.19.1.16 enum POS_CAPTURE_STAT

Position capture status register value.

The current status of the position capture mechanism may be read from the amplifier using the method [Amp::GetPos-CaptureCfg](#).

This status value is bitmapped as described by this enumeration. Any bits not described here should be ignored. Bits not described here are reserved and may be either 1 or 0.

Enumerator

CAPTURE_INDEX_FULL If this bit is set it indicates that a new encoder index position has been captured. This position may be read using the method [Amp::GetIndexCapture](#). Reading the captured position will cause this bit to be cleared.

CAPTURE_INDEX_OVER If this bit is set it indicates that a new encoder index was received before the previous captured index position was read from the amplifier. The setting of the CAPTURE_INDEX_LATCH bit in the capture control register determines whether or not the new captured position was stored. If the CAPTURE_INDEX_LATCH configuration bit is set, then the new captured position will be lost. If this bit is clear then the newly captured position will overwrite the previous position.
Reading the captured position will cause this bit to be cleared.

CAPTURE_HOME_FULL If this bit is set it indicates that a new home sensor position has been captured. This position may be read using the method [Amp::GetHomeCapture](#). Reading the captured position will cause this bit to be cleared.

CAPTURE_HOME_OVER If this bit is set it indicates that a new home sensor transition was received before the previous captured home position was read from the amplifier. The setting of the CAPTURE_HOME_LATCH bit in the capture control register determines whether or not the new captured position was stored. If the CAPTURE_HOME_LATCH configuration bit is set, then the new captured position will be lost. If this bit is clear then the newly captured position will overwrite the previous position.
Reading the captured position will cause this bit to be cleared.

6.19.1.17 enum PROFILE_TYPE

[Point](#) to point profile types.

This enumeration gives the various profile types supported by the Copley amplifiers. These profile types are used when running in profile position mode (point to point moves).

Enumerator

PROFILE_VEL Velocity profile. In this profile mode the velocity, acceleration and deceleration values are used. The position value is also used, but it only defines the direction of motion (positive is position is ≥ 0 , negative if position is < 0).

PROFILE_TRAP Trapezoidal profile. In this profile mode a position, velocity, acceleration and deceleration may be specified. This profile mode allows any of its parameters (position, vel, accel, decel) to be changed during the course of a move.

PROFILE_SCURVE Jerk limited (S-curve) profile. In this mode, position, velocity, acceleration, and jerk (rate of change of acceleration) may be specified.

PROFILE_CSP Cyclic Synchronous Position (CSP) profile.

6.19.1.18 enum QUICK_STOP_MODE

The amplifier's quick stop mode defines its action when a quick stop command is issued ([Amp::QuickStop](#)).

The quick stop command differs from the halt command in that the amplifier is always disabled at the end of the sequence. For some modes, the amplifier automatically disables after halting the move. For others, the amplifier halts the move and holds in the quick stop state. No new moves may be started until the amplifier has manually been disabled.

Enumerator

QSTOP_DISABLE Disable the amplifier immediately.

QSTOP_DECEL Slow down using the profile deceleration then disable.

QSTOP_QUICKSTOP Slow down using the quick stop deceleration then disable.

QSTOP_ABRUPT Slow down with unlimited deceleration then disable.

QSTOP_DECEL_HOLD Slow down and hold.

QSTOP_QUICKSTOP_HOLD Quick stop and hold.

QSTOP_ABRUPT_HOLD Abrupt stop and hold.

6.20 CML_AmpStruct.h File Reference

This file contains a number of structures used to pass configuration parameters to an [Amp](#) object.

Include dependency graph for CML_AmpStruct.h:

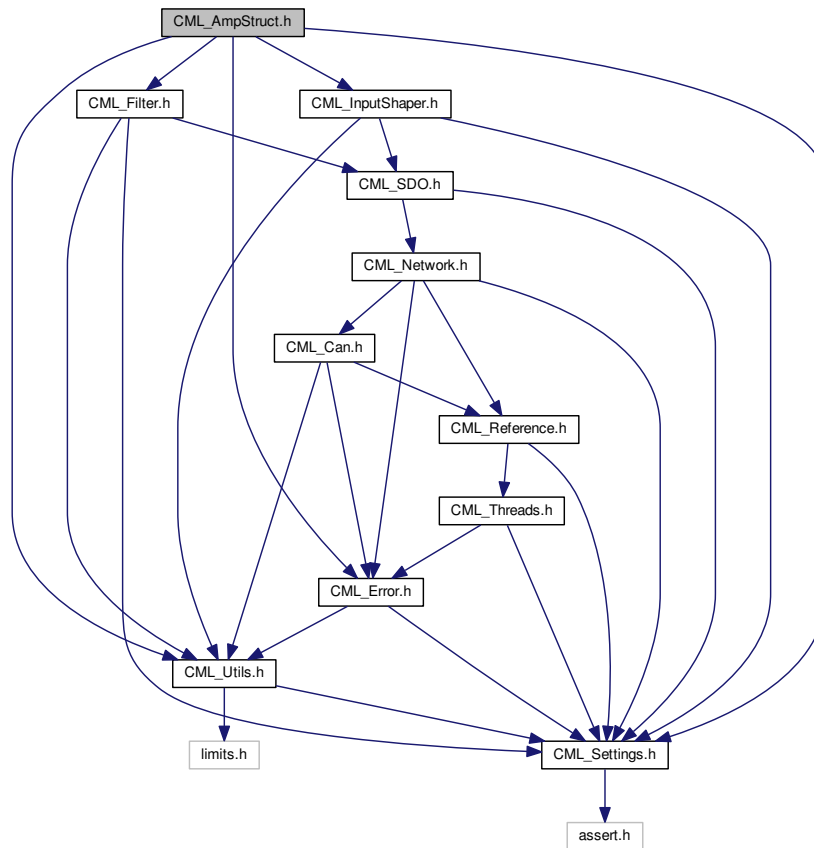

This graph shows which files directly or indirectly include this file:



Classes

- class [AmpFileError](#)
This class represents error conditions that can occur when loading amplifier data from a data file.
- struct [AmpInfo](#)
Amplifier characteristics data structure.
- struct [PosLoopConfig](#)
This structure holds the position loop configuration parameters specific to the Copley amplifier.
- struct [ServoLoopConfig](#)
This structure holds configuration info about specific parts of the velocity and position loops.

- struct [VelLoopConfig](#)
This structure holds the velocity loop configuration parameters specific to the Copley amplifier.
- struct [CrntLoopConfig](#)
This structure holds the current loop configuration parameters.
- struct [HomeConfig](#)
Homing parameter structure.
- struct [ProfileConfig](#)
Amplifier profile parameters.
- struct [TrackingWindows](#)
Position and velocity error windows.
- struct [MtrInfo](#)
Motor information structure.
- struct [AmplCfg](#)
Programmable I/O pin configuration.
- struct [SoftPosLimit](#)
Software limit switch configuration.
- struct [RegenConfig](#)
Configuration structure used to set up the amplifier regeneration resister.
- struct [FuncGenConfig](#)
Configuration parameters for amplifier's internal function generator.
- struct [AnalogRefConfig](#)
Analog input configuration.
- struct [PwmInConfig](#)
PWM or Pulse/Direction input configuration.
- struct [CanNetworkConfig](#)
CANopen Node ID and bit rate configuration.
- struct [NetworkOptions](#)
Configuration structure used to configure the amplifiers network support.
- struct [DAConfig](#)
Configuration structure used to hold the settings for a drive's D/A converter.
- struct [UstepConfig](#)
Configuration structure used to set up the microstepper.
- struct [AlgoPhaseInit](#)
Configuration structure used to set up algorithmic phase init.
- struct [CammingConfig](#)
Configuration structure used to set up the camming.
- struct [GainScheduling](#)
Configuration structure used to set up the Gain Scheduling.
- struct [AmpConfig](#)
Amplifier configuration structure.

Macros

- #define [COPLEY_MAX_INPUTS](#) 26
Maximum available on any amplifier.

Enumerations

- enum `CAN_BIT_RATE` {
 `CAN_RATE_1MEG` = 0x0000,
 `CAN_RATE_800K` = 0x1000,
 `CAN_RATE_500K` = 0x2000,
 `CAN_RATE_250K` = 0x3000,
 `CAN_RATE_125K` = 0x4000,
 `CAN_RATE_50K` = 0x5000,
 `CAN_RATE_20K` = 0x6000,
 `CAN_RATE_100K` = 0x8000 }

CANopen network bit rate enumeration.

6.20.1 Detailed Description

This file contains a number of structures used to pass configuration parameters to an [Amp](#) object.

6.20.2 Enumeration Type Documentation

6.20.2.1 enum `CAN_BIT_RATE`

CANopen network bit rate enumeration.

Enumerator

`CAN_RATE_1MEG` 1,000,000 bits / second

`CAN_RATE_800K` 800,000 bits / second

`CAN_RATE_500K` 500,000 bits / second

`CAN_RATE_250K` 250,000 bits / second

`CAN_RATE_125K` 125,000 bits / second

`CAN_RATE_50K` 50,000 bits / second

`CAN_RATE_20K` 20,000 bits / second

`CAN_RATE_100K` 100,000 bits / second

6.21 CML_Array.h File Reference

This file implements a simple dynamic array template used in CML.

Include dependency graph for CML_Array.h:

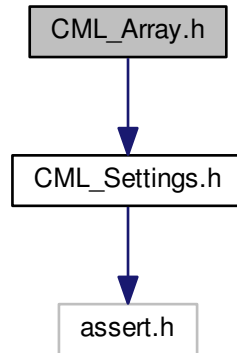

This graph shows which files directly or indirectly include this file:



Classes

- class [Array< C >](#)

This class template implements a simple dynamic array of a given type.

6.21.1 Detailed Description

This file implements a simple dynamic array template used in CML.

6.22 CML_Can.h File Reference

This file contains the base classes used to define the low level interface to the CAN network hardware.

Include dependency graph for CML_Can.h:

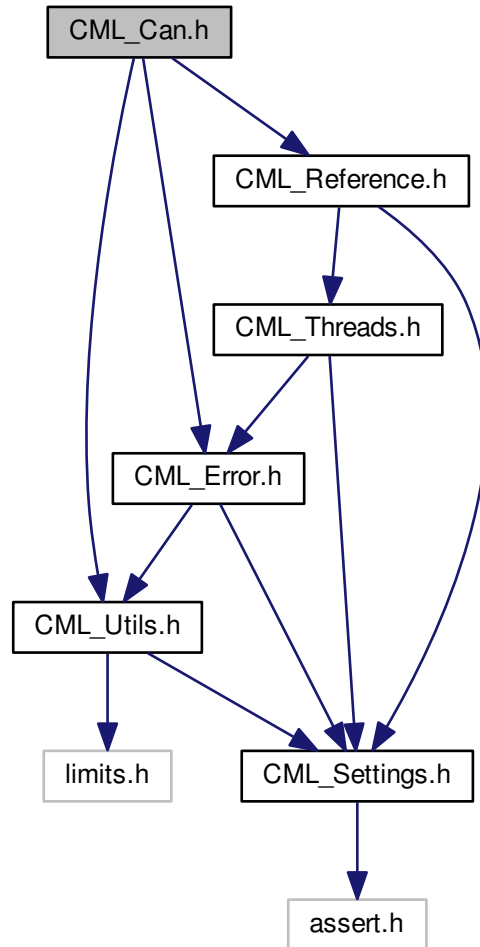

This graph shows which files directly or indirectly include this file:

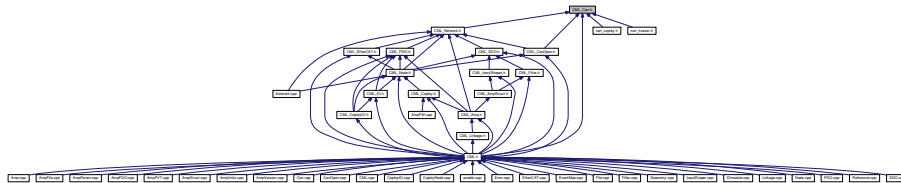

Classes

- struct [CanFrame](#)

Low level CAN data frame.

- class [CanError](#)

Class used to represent an error condition returned from a CAN interface function.

- class [CanInterface](#)

Abstract class used for low level interaction with CAN hardware.

Enumerations

- enum [CAN_FRAME_TYPE](#) {
 [CAN_FRAME_DATA](#),
 [CAN_FRAME_REMOTE](#),
 [CAN_FRAME_ERROR](#) }

This enumeration is used to identify the type of CAN frame.

6.22.1 Detailed Description

This file contains the base classes used to define the low level interface to the CAN network hardware.

6.22.2 Enumeration Type Documentation

6.22.2.1 enum [CAN_FRAME_TYPE](#)

This enumeration is used to identify the type of CAN frame.

Enumerator

[CAN_FRAME_DATA](#) Standard CAN data frame.

[CAN_FRAME_REMOTE](#) Remote frame.

[CAN_FRAME_ERROR](#) [Error](#) frame.

6.23 CML_CanOpen.h File Reference

This header file defines the classes used for the top level of the CANopen network.

Include dependency graph for CML_CanOpen.h:

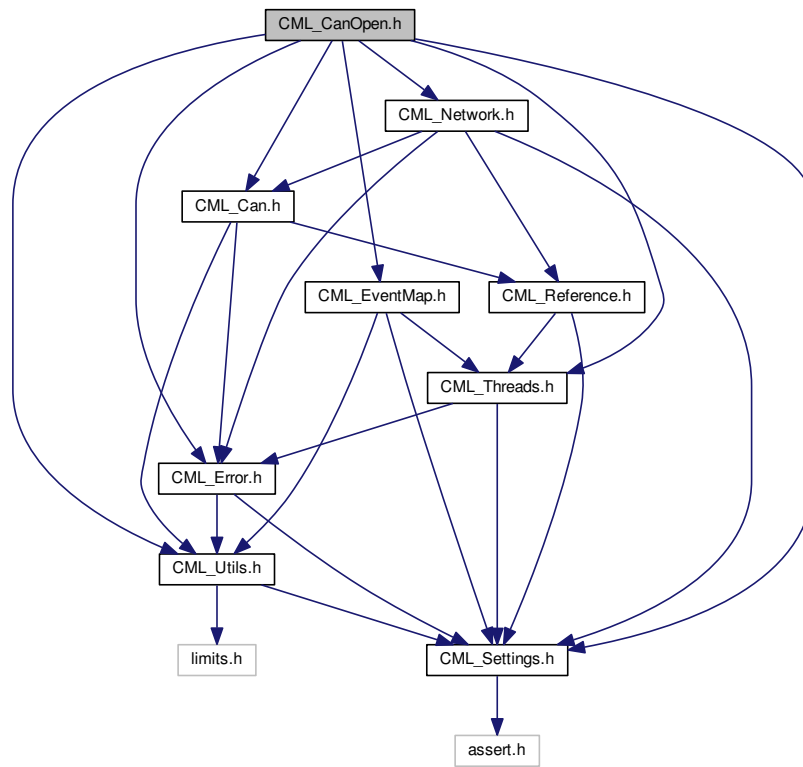

This graph shows which files directly or indirectly include this file:

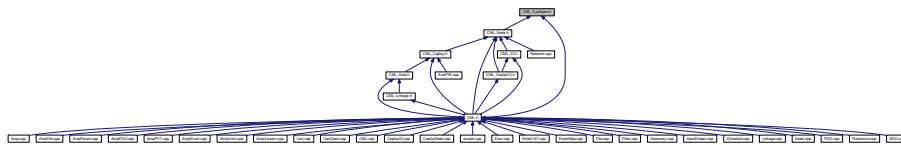

Classes

- class [CanOpenError](#)
This class holds the error codes that describe CANopen error conditions.
- class [CanOpenSettings](#)
Configuration object used to customize global settings for the CANopen network.
- struct [CanOpenNodeInfo](#)
The [CanOpenNodeInfo](#) structure holds some data required by the CANopen network interface which is present in every node it manages.
- class [CanOpen](#)
The [CanOpen](#) class is the top level interface into the CANopen network.

- class [Receiver](#)
CANopen receiver object.
- class [LSS](#)
CANopen Layer Setting Services object.

6.23.1 Detailed Description

This header file defines the classes used for the top level of the CANopen network.

6.24 CML_Copley.h File Reference

This header file defines a generic Copley node type.

Include dependency graph for CML_Copley.h:

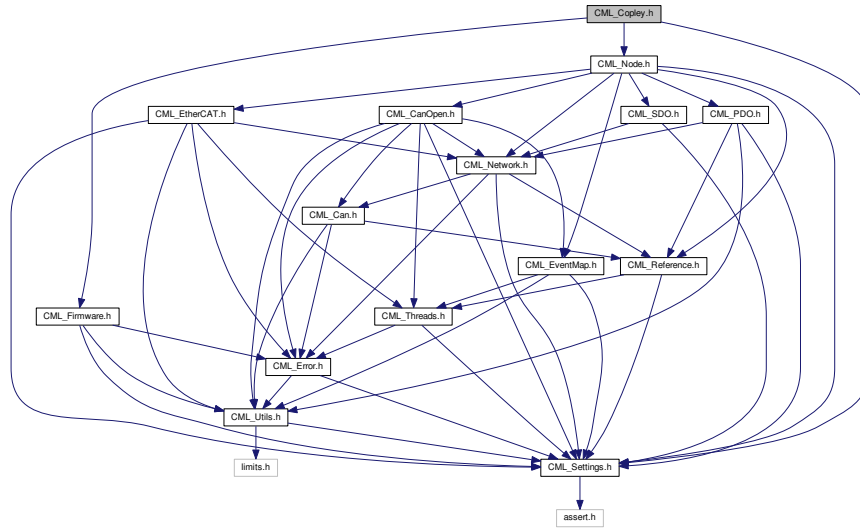

This graph shows which files directly or indirectly include this file:



Classes

- class [CopleyNodeError](#)
This class represents errors that can be returned by the [CopleyNode](#) class.
- class [CopleyNode](#)
Copley CANopen [Node](#) class.

6.24.1 Detailed Description

This header file defines a generic Copley node type. This is the base class of all CANopen devices produced by Copley Controls Corp.

6.25 CML_CopleyIO.h File Reference

Standard CANopen I/O module support.

Include dependency graph for CML_CopleyIO.h:

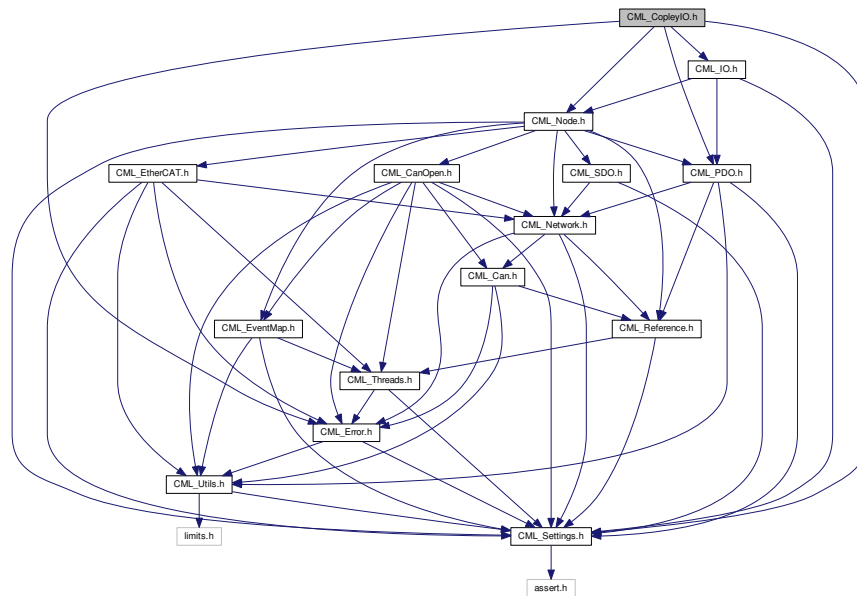

This graph shows which files directly or indirectly include this file:

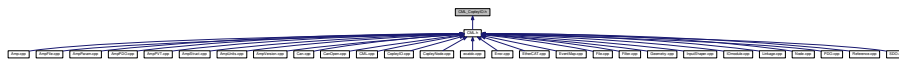

Classes

- struct [CopleyIOInfo](#)
IO Module characteristics data structure.
- struct [CopleyIODigi](#)
This structure is used to return information about the digital I/O of a Copley I/O module.
- struct [CopleyIOAnlg](#)
This structure is used to return information about the analog inputs of a Copley I/O module.
- struct [CopleyIOPWM](#)
This structure is used to return information about the PWM outputs of a Copley I/O module.

- struct [CopleyIOCfg](#)

IO Module configuration structure.

- class [CopleyIO](#)

This class represents a Copley CANopen I/O module.

- class [IOFileError](#)

This class represents error conditions that can occur when loading IO module data from a data file.

Enumerations

- enum CIO_OBJID {
 - CIOOBJID_INFO_SERIAL = 0x3000,
 - CIOOBJID_INFO_MODEL = 0x3001,
 - CIOOBJID_INFO_MFGINFO = 0x3002,
 - CIOOBJID_INFO_HWTYPE = 0x3003,
 - CIOOBJID_INFO_LOOPRATE = 0x3004,
 - CIOOBJID_INFO_FWVERSION = 0x3010,
 - CIOOBJID_INFO_BAUD = 0x3011,
 - CIOOBJID_INFO_MAXWORDS = 0x3012,
 - CIOOBJID_INFO_NAME = 0x3013,
 - CIOOBJID_INFO_HOSTCFG = 0x3014,
 - CIOOBJID_INFO_NODECFG = 0x3015,
 - CIOOBJID_INFO_RATECFG = 0x3016,
 - CIOOBJID_INFO_NODEID = 0x3017,
 - CIOOBJID_INFO_STATUS = 0x3018,
 - CIOOBJID_INFO_RATE = 0x3019,
 - CIOOBJID_INFO_ANLGINT = 0x301A,
 - CIOOBJID_INFO_ANLGINTENA = 0x301B,
 - CIOOBJID_INFO_DIGIINTENA = 0x301C,
 - CIOOBJID_INFO_PWMPERIODA = 0x301E,
 - CIOOBJID_INFO_PWMPERIODB = 0x301F,
 - CIOOBJID_DIGI_BANKMODE = 0x3020,
 - CIOOBJID_DIGI_PULLUPMSK = 0x3021,
 - CIOOBJID_DIGI_TYPEMSK = 0x3022,
 - CIOOBJID_DIGI_FAULTMSK = 0x3023,
 - CIOOBJID_DIGI_INVMSK = 0x3024,
 - CIOOBJID_DIGI_VALUEMSK = 0x3025,
 - CIOOBJID_DIGI_MODEMSK = 0x3026,
 - CIOOBJID_DIGI_RAWMSK = 0x3027,
 - CIOOBJID_DIGI_HILOMSK = 0x3028,
 - CIOOBJID_DIGI_LOHIMSK = 0x3029,
 - CIOOBJID_DIGI_DEBOUNCE0 = 0x3030,
 - CIOOBJID_DIGI_DEBOUNCE1 = 0x3031,
 - CIOOBJID_DIGI_DEBOUNCE2 = 0x3032,
 - CIOOBJID_DIGI_DEBOUNCE3 = 0x3033,
 - CIOOBJID_DIGI_DEBOUNCE4 = 0x3034,
 - CIOOBJID_DIGI_DEBOUNCE5 = 0x3035,
 - CIOOBJID_DIGI_DEBOUNCE6 = 0x3036,
 - CIOOBJID_DIGI_DEBOUNCE7 = 0x3037,
 - CIOOBJID_ANLG_IRAW = 0x3040,
 - CIOOBJID_ANLG_ISCALED = 0x3041,
 - CIOOBJID_ANLG_IFACTOR = 0x3042,
 - CIOOBJID_ANLG_IOFFSET = 0x3043,
 - CIOOBJID_ANLG_IUPLIMIT = 0x3044,
 - CIOOBJID_ANLG_ILOLIMIT = 0x3045,
 - CIOOBJID_ANLG_IABSDDELTA = 0x3046,
 - CIOOBJID_ANLG_IPOSDELTA = 0x3047,
 - CIOOBJID_ANLG_INEGDELTA = 0x3048,
 - CIOOBJID_ANLG_IFLAGS = 0x3049,
 - CIOOBJID_ANLG_IMASK = 0x304A,
 - CIOOBJID_PWM_ORAW = 0x3050,
 - CIOOBJID_PWM_OSCALED = 0x3051,
 - CIOOBJID_PWM_OFACTOR = 0x3052,

```
CIOOBJID_PWM_OOFFSET = 0x3053 }
```

Object dictionary ID values used on Copley I/O modules.

6.25.1 Detailed Description

Standard CANopen I/O module support.

6.25.2 Enumeration Type Documentation

6.25.2.1 enum CIO_OBJID

Object dictionary ID values used on Copley I/O modules.

Enumerator

CIOOBJID_INFO_SERIAL Serial number.

CIOOBJID_INFO_MODEL Model number string.

CIOOBJID_INFO_MFGINFO Amplifier's manufacturing information string.

CIOOBJID_INFO_HWTYPE Hardware type code.

CIOOBJID_INFO_LOOPRATE Main loop update rate (Hz)

CIOOBJID_INFO_FWVERSION [Firmware](#) version number.

CIOOBJID_INFO_BAUD Serial port baud rate (bps)

CIOOBJID_INFO_MAXWORDS Maximum number of words sent with any command.

CIOOBJID_INFO_NAME I/O module name.

CIOOBJID_INFO_HOSTCFG Host configuration state (CME use only)

CIOOBJID_INFO_NODECFG CAN node ID configuration.

CIOOBJID_INFO_RATECFG CAN bit rate configuration.

CIOOBJID_INFO_NODEID CAN node ID.

CIOOBJID_INFO_STATUS CAN network status word.

CIOOBJID_INFO_RATE CAN network bit rate.

CIOOBJID_INFO_ANLGINT Active analog interrupts.

CIOOBJID_INFO_ANLGINTENA Analog input global interrupt enable.

CIOOBJID_INFO_DIGIINTENA Digital input global interrupt enable.

CIOOBJID_INFO_PWMPERIODA PWM bank A period.

CIOOBJID_INFO_PWMPERIODB PWM bank B period.

CIOOBJID_DIGI_BANKMODE Digital I/O bank mode.

CIOOBJID_DIGI_PULLUPMSK Digital I/O pull-up resistor mask.

CIOOBJID_DIGI_TPEMSK Digital I/O output type mask.

CIOOBJID_DIGI_FAULTMSK Digital I/O output fault state mask.

CIOOBJID_DIGI_INVMSK Digital I/O inversion mask.

CIOOBJID_DIGI_VALUEMSK Digital I/O data value mask.

CIOOBJID_DIGI_MODEMSK Digital I/O output fault mode mask.

CIOOBJID_DIGI_RAWMSK Digital I/O raw data value mask.

CIOOBJID_DIGI_HILOMSK Digital I/O input low->high interrupt mask.

CIOOBJID_DIGI_LOHIMSK Digital I/O input high->low interrupt mask.

CIOOBJID_DIGI_DEBOUNCE0 Digital I/O debounce time, bit 0.

CIOOBJID_DIGI_DEBOUNCE1 Digital I/O debounce time, bit 1.

CIOOBJID_DIGI_DEBOUNCE2 Digital I/O debounce time, bit 2.

CIOOBJID_DIGI_DEBOUNCE3 Digital I/O debounce time, bit 3.

CIOOBJID_DIGI_DEBOUNCE4 Digital I/O debounce time, bit 4.

CIOOBJID_DIGI_DEBOUNCE5 Digital I/O debounce time, bit 5.

CIOOBJID_DIGI_DEBOUNCE6 Digital I/O debounce time, bit 6.

CIOOBJID_DIGI_DEBOUNCE7 Digital I/O debounce time, bit 7.

CIOOBJID_ANLG_IRAW Analog input raw value.

CIOOBJID_ANLG_ISCALED Analog input scaled value.

CIOOBJID_ANLG_IFACTOR Analog input scaling factor.

CIOOBJID_ANLG_IOFFSET Analog input offset.

CIOOBJID_ANLG_IUPLIMIT Analog input upper limit for interrupt.

CIOOBJID_ANLG_ILOLIMIT Analog input lower limit for interrupt.

CIOOBJID_ANLG_IABSDDELTA Analog input absolute delta value for interrupt.

CIOOBJID_ANLG_IPOSEDELTA Analog input positive delta value for interrupt.

CIOOBJID_ANLG_INEGDELTA Analog input negative delta value for interrupt.

CIOOBJID_ANLG_IFLAGS Analog input interrupt flags.

CIOOBJID_ANLG_IMASK Analog input interrupt mask.

CIOOBJID_PWM_ORAW PWM output raw value.

CIOOBJID_PWM_OSCALED PWM output scaled value.

CIOOBJID_PWM_OFACTOR PWM output scaling factor.

CIOOBJID_PWM_OOFFSET PWM output offset.

6.26 CML_Error.h File Reference

This file defines the top level error class used throughout the library.

Include dependency graph for CML_Error.h:

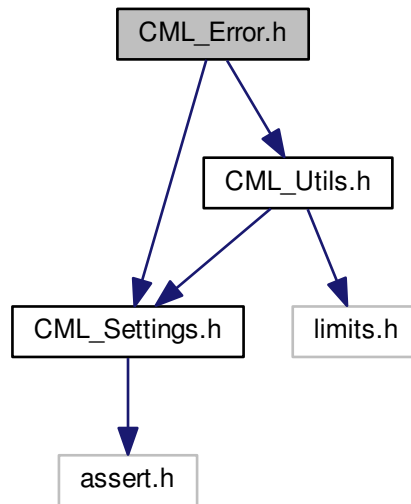

This graph shows which files directly or indirectly include this file:

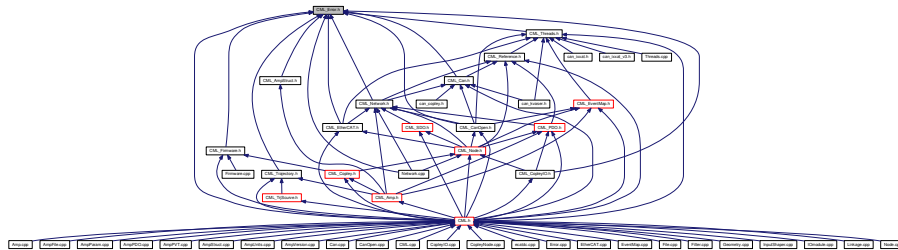

Classes

- class [Error](#)

This class is the root class for all error codes returned by functions defined within the Motion Library.

6.26.1 Detailed Description

This file defines the top level error class used throughout the library.

6.27 CML_EtherCAT.h File Reference

This header file defines the classes used to represent the top level of the [EtherCAT](#) network interface.

Include dependency graph for CML_EtherCAT.h:

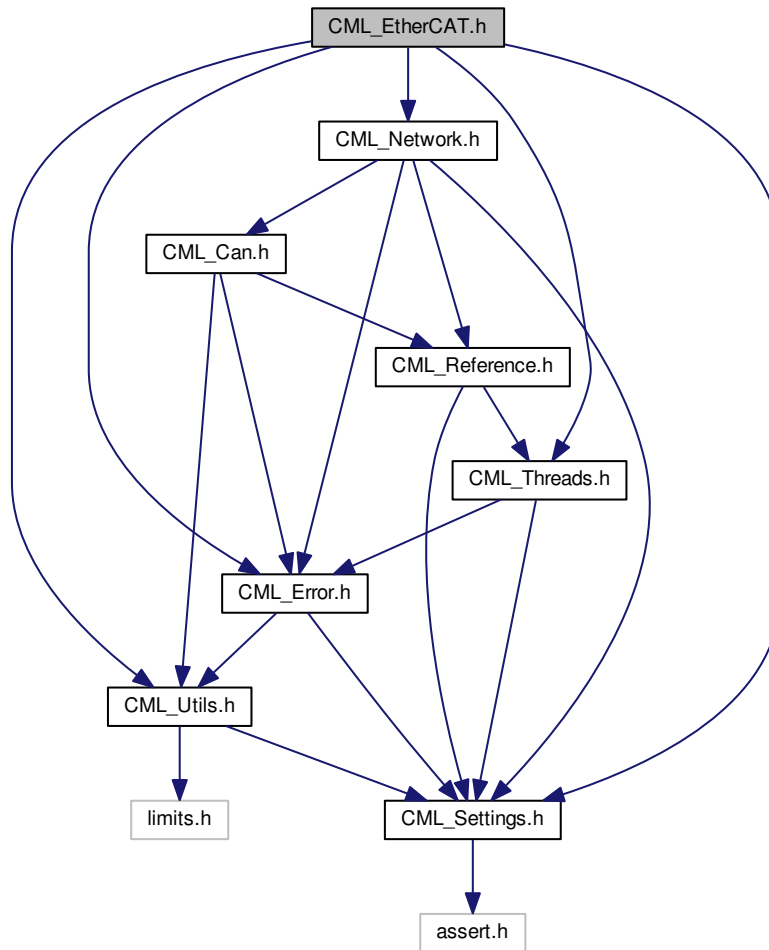

This graph shows which files directly or indirectly include this file:

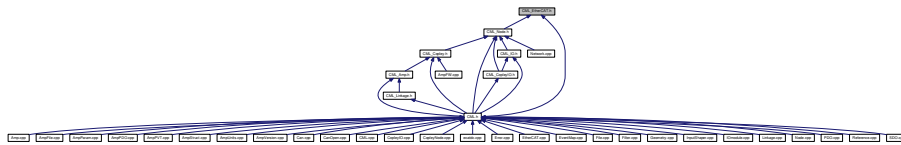

Classes

- class [EtherCatError](#)
This class holds the error codes that describe [EtherCAT](#) error conditions.
- class [EtherCatSettings](#)

Configuration object used to customize global settings for the [EtherCAT](#) network.

- class [EtherCatHardware](#)

Low level Ethernet hardware interface.

- class [EtherCAT](#)

The [EtherCAT](#) class is the top level interface into the [EtherCAT](#) network.

- class [EcatDgram](#)

Generic [EtherCAT](#) datagram class.

- struct [BRD](#)

Broadcast read.

- struct [BWR](#)

Broadcast write. This type of datagram writes data to the same location on every node in the network.

- struct [APRD](#)

Read by position in network (aka Auto Increment Physical Read) The read is performed on the node who's position matches the passed address.

- struct [APWR](#)

Write by position in network (Auto Increment Physical Write) Like the [APRD](#) datagram, but a write version.

- struct [ARMW](#)

Read by position in network and write to the same address of all following nodes.

- struct [FPRD](#)

Read by assigned node ID (Configured Address Physical Read) The master assigns each node a unique 16-bit address at startup.

- struct [FPWR](#)

Write by assigned node ID (Configured Address Physical Write)

- class [EcatFrame](#)

[EtherCAT](#) frame class.

6.27.1 Detailed Description

This header file defines the classes used to represent the top level of the [EtherCAT](#) network interface.

6.28 CML_EventMap.h File Reference

This file defines the [Event](#) Map class.

Include dependency graph for CML_EventMap.h:

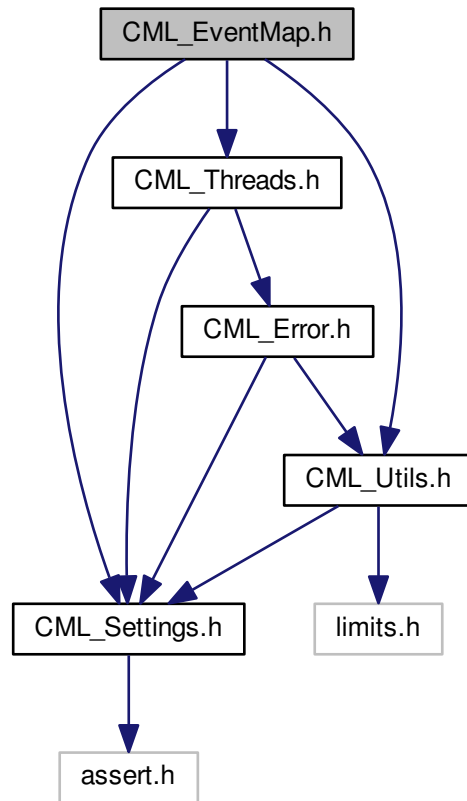

This graph shows which files directly or indirectly include this file:

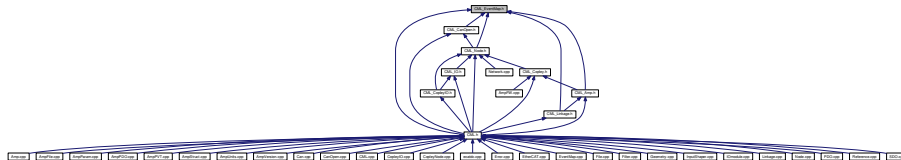

Classes

- class [EventError](#)
This class represents error conditions related to the [Event](#) object.
- class [Event](#)
Events are a generic mechanism used to wait on some condition.
- class [EventAny](#)

This is an event that matches if any of a group of bits are set in the [EventMap](#) mask.

- class [EventAnyClear](#)

This is an event that matches if any of a group of bits are clear in the [EventMap](#) mask.

- class [EventAll](#)

This is an event that matches if all of a group of bits are set in the [EventMap](#) mask.

- class [EventNone](#)

This is an event that matches if none of a group of bits are set in the [EventMap](#) mask.

- class [EventMap](#)

An event map is a mechanism that allows one or more threads to wait on some pre-defined event, or group of events.

6.28.1 Detailed Description

This file defines the [Event](#) Map class.

6.29 CML_File.h File Reference

This file holds various handy functions for parsing files.

Include dependency graph for CML_File.h:

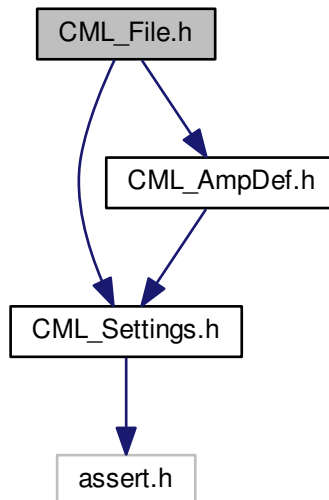

This graph shows which files directly or indirectly include this file:

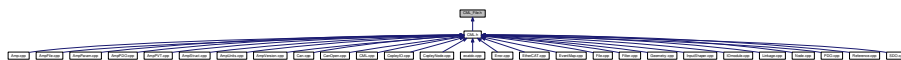

6.29.1 Detailed Description

This file holds various handy functions for parsing files.

6.30 CML_Filter.h File Reference

This file defines the [Filter](#) object.

Include dependency graph for CML_Filter.h:

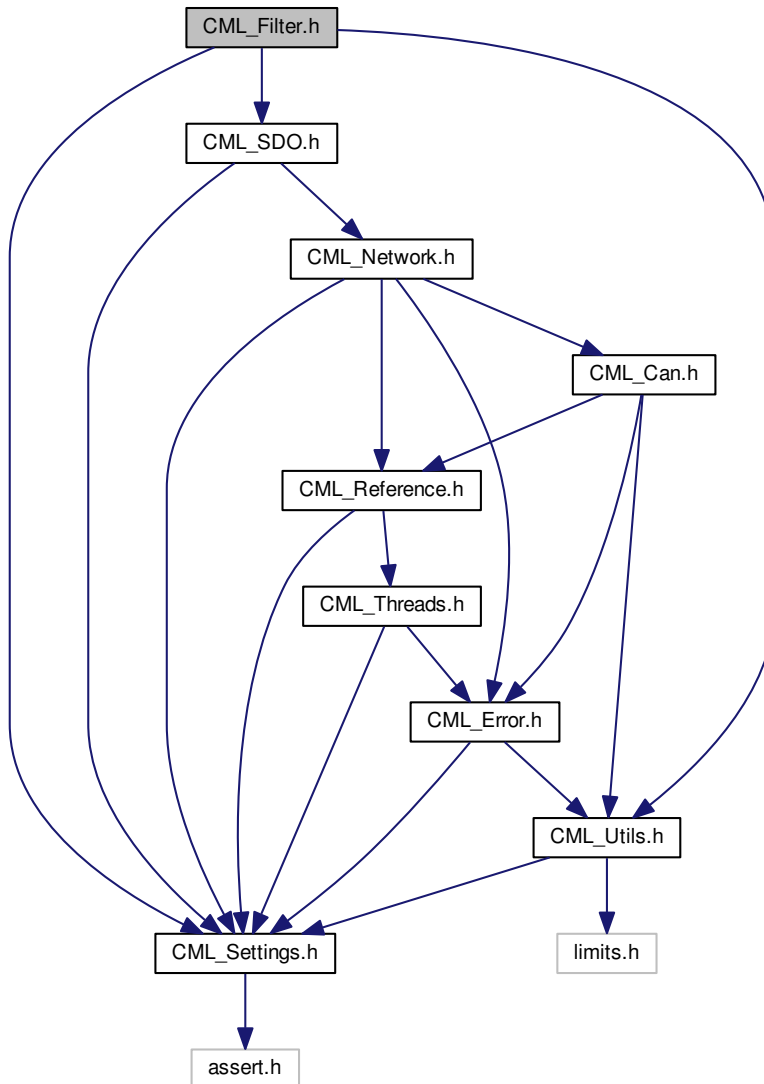

This graph shows which files directly or indirectly include this file:

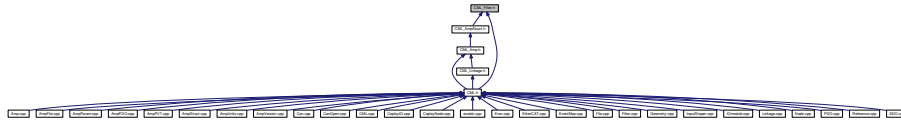

Classes

- class [Filter](#)

Generic filter structure.

6.30.1 Detailed Description

This file defines the [Filter](#) object. The [Filter](#) object represents a two pole filter structure used in various locations within the amplifier.

6.31 CML_Firmware.h File Reference

This file defines classes related to the Copley amplifier [Firmware](#) object.

Include dependency graph for CML_Firmware.h:

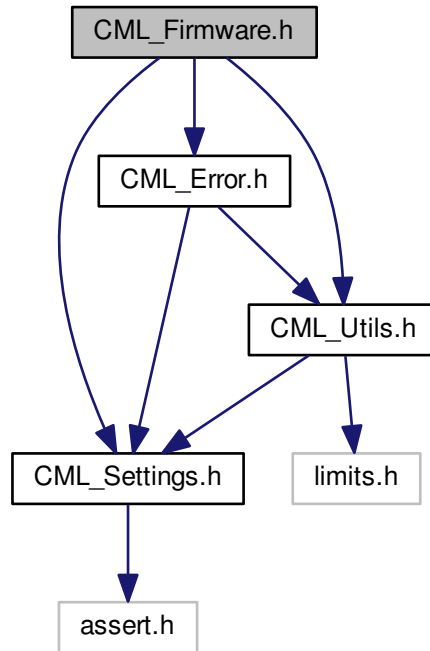

This graph shows which files directly or indirectly include this file:



Classes

- class [FirmwareError](#)
This class represents error conditions that can occur while accessing a Copley Controls amplifier firmware object.
- class [Firmware](#)
Copley Controls amplifier firmware object.

6.31.1 Detailed Description

This file defines classes related to the Copley amplifier [Firmware](#) object. The firmware object is used to update the program within the amplifier. An object of this type must be passed to the [Amp::FirmwareUpdate](#) method to perform this task.

Note that firmware updates are likely to be rare, and are not part of normal operation.

6.32 CML_Geometry.h File Reference

This file contains class definitions used to define multi-axis trajectory paths.

Include dependency graph for CML_Geometry.h:

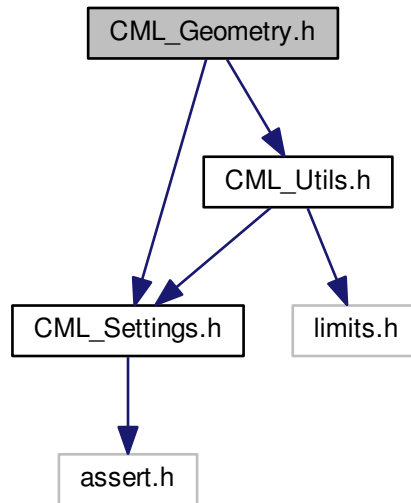

This graph shows which files directly or indirectly include this file:



Classes

- class [PointN](#)
An N axis point.
- class [Point< N >](#)
Template used for N dimensional objects.

6.32.1 Detailed Description

This file contains class definitions used to define multi-axis trajectory paths.

6.33 CML_InputShaper.h File Reference

This file defines the [InputShaper](#) object.

Include dependency graph for CML_InputShaper.h:

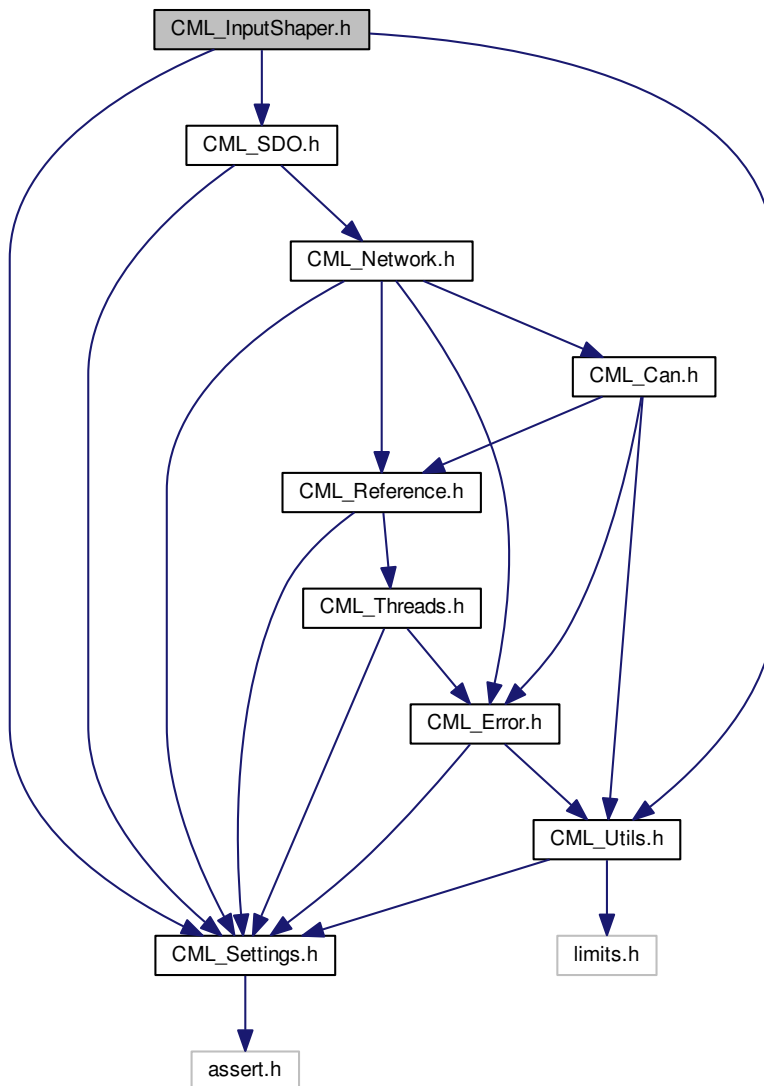

This graph shows which files directly or indirectly include this file:

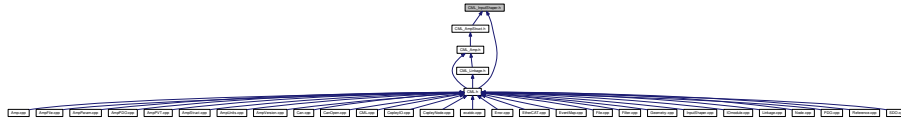

Classes

- class [InputShaper](#)

Generic input shaper structure.

6.33.1 Detailed Description

This file defines the [InputShaper](#) object. The [InputShaper](#) represents a series of impulse functions convolved with an input function.

6.34 CML_IO.h File Reference

Standard CANopen I/O module support.

Include dependency graph for CML_IO.h:

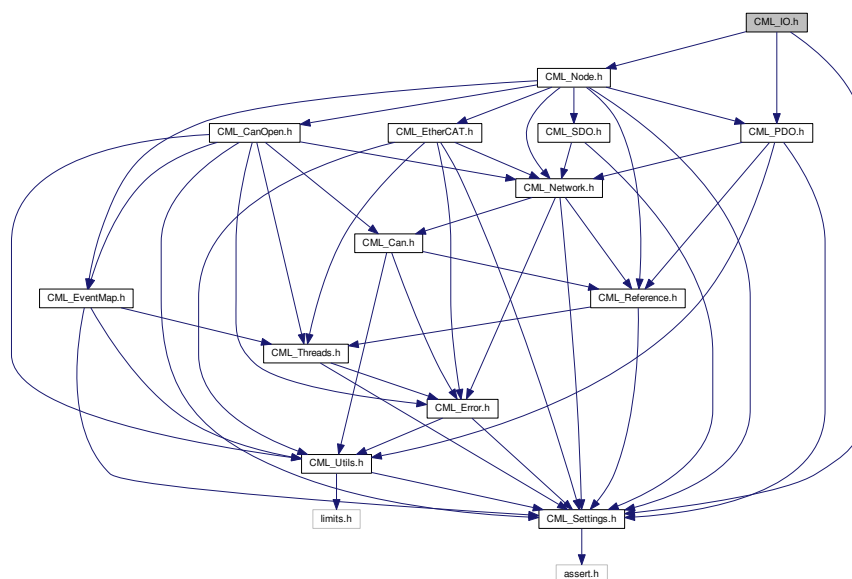

This graph shows which files directly or indirectly include this file:



Classes

- class [IOError](#)

I/O module errors.

- struct [IOModuleSettings](#)

Standard CANopen I/O module settings.

- class [IOModule](#)

Standard CANopen I/O module.

- class [IOModule::DigOutPDO](#)

Receive PDO for mapping digital output pins.

- class [IOModule::AlgOutPDO](#)

Receive PDO for mapping analog outputs.

- class [IOModule::DigInPDO](#)

Transmit PDO for mapping digital inputs.

- class [IOModule::AlgInPDO](#)

Transmit PDO for mapping analog inputs.

Enumerations

- enum IO_OBJID {
 - IOOBJID_DIN_8_VALUE = 0x6000,
 - IOOBJID_DIN_8_POL = 0x6002,
 - IOOBJID_DIN_8_FILT = 0x6003,
 - IOOBJID_DIN_INTENA = 0x6005,
 - IOOBJID_DIN_8_MASK_ANY = 0x6006,
 - IOOBJID_DIN_8_MASK_L2H = 0x6007,
 - IOOBJID_DIN_8_MASK_H2L = 0x6008,
 - IOOBJID_DIN_1_VALUE = 0x6020,
 - IOOBJID_DIN_1_POL = 0x6030,
 - IOOBJID_DIN_1_FILT = 0x6038,
 - IOOBJID_DIN_1_MASK_ANY = 0x6050,
 - IOOBJID_DIN_1_MASK_L2H = 0x6060,
 - IOOBJID_DIN_1_MASK_H2L = 0x6070,
 - IOOBJID_DIN_16_VALUE = 0x6100,
 - IOOBJID_DIN_16_POL = 0x6102,
 - IOOBJID_DIN_16_FILT = 0x6103,
 - IOOBJID_DIN_16_MASK_ANY = 0x6106,
 - IOOBJID_DIN_16_MASK_L2H = 0x6107,
 - IOOBJID_DIN_16_MASK_H2L = 0x6108,
 - IOOBJID_DIN_32_VALUE = 0x6120,
 - IOOBJID_DIN_32_POL = 0x6122,
 - IOOBJID_DIN_32_FILT = 0x6123,
 - IOOBJID_DIN_32_MASK_ANY = 0x6126,
 - IOOBJID_DIN_32_MASK_L2H = 0x6127,
 - IOOBJID_DIN_32_MASK_H2L = 0x6128,
 - IOOBJID_DOUT_8_VALUE = 0x6200,
 - IOOBJID_DOUT_8_POL = 0x6202,
 - IOOBJID_DOUT_8_ERRMODE = 0x6206,
 - IOOBJID_DOUT_8_ERRVAL = 0x6207,
 - IOOBJID_DOUT_8_FILT = 0x6208,
 - IOOBJID_DOUT_1_VALUE = 0x6220,
 - IOOBJID_DOUT_1_POL = 0x6240,
 - IOOBJID_DOUT_1_ERRMODE = 0x6250,
 - IOOBJID_DOUT_1_ERRVAL = 0x6260,
 - IOOBJID_DOUT_1_FILT = 0x6270,
 - IOOBJID_DOUT_16_VALUE = 0x6300,
 - IOOBJID_DOUT_16_POL = 0x6302,
 - IOOBJID_DOUT_16_ERRMODE = 0x6306,
 - IOOBJID_DOUT_16_ERRVAL = 0x6307,
 - IOOBJID_DOUT_16_FILT = 0x6308,
 - IOOBJID_DOUT_32_VALUE = 0x6320,
 - IOOBJID_DOUT_32_POL = 0x6322,
 - IOOBJID_DOUT_32_ERRMODE = 0x6326,
 - IOOBJID_DOUT_32_ERRVAL = 0x6327,
 - IOOBJID_DOUT_32_FILT = 0x6328,
 - IOOBJID_AIN_8_VALUE = 0x6400,
 - IOOBJID_AIN_16_VALUE = 0x6401,
 - IOOBJID_AIN_32_VALUE = 0x6402,
 - IOOBJID_AIN_FLT_VALUE = 0x6403,
 - IOOBJID_AIN_MFG_VALUE = 0x6404,
 - IOOBJID_AOUT_8_VALUE = 0x6410,
 - IOOBJID_AOUT_16_VALUE = 0x6411,
 - IOOBJID_AOUT_32_VALUE = 0x6412,
 - IOOBJID_AOUT_MFG_VALUE = 0x6414,
 - IOOBJID_AIN_TRIG = 0x6421,
 - IOOBJID_AIN_INTSRC = 0x6422,
 - IOOBJID_AIN_INTENA = 0x6423,

```
IOOBJID_AOUT_UNIT = 0x6450 }
```

Object dictionary ID values used on standard I/O modules.

- enum **IO_AIN_TRIG_TYPE** {
IOAINTRIG_UPPER_LIM = 0x0001,
IOAINTRIG_LOWER_LIM = 0x0002,
IOAINTRIG_UDELTA = 0x0004,
IOAINTRIG_NDELTA = 0x0008,
IOAINTRIG_PDELTA = 0x0010 }

This enumeration is used to define the types of events that may cause an analog input to generate an interrupt event.

- enum **IOMODULE_EVENTS** {
IOEVENT_DIN_PDO0 = 0x00000001,
IOEVENT_AIN_PDO0 = 0x00010000,
IOEVENT_AIN_PDO1 = 0x00020000,
IOEVENT_AIN_PDO2 = 0x00040000 }

This enumeration gives the various events that can be waited on.

6.34.1 Detailed Description

Standard CANopen I/O module support.

6.34.2 Enumeration Type Documentation

6.34.2.1 enum IO_AIN_TRIG_TYPE

This enumeration is used to define the types of events that may cause an analog input to generate an interrupt event.

Enumerator

- IOAINTRIG_UPPER_LIM** Input above upper limit.
- IOAINTRIG_LOWER_LIM** Input below lower limit.
- IOAINTRIG_UDELTA** Input changed by more then the unsigned delta amount.
- IOAINTRIG_NDELTA** Input reduced by more then the negative delta amount.
- IOAINTRIG_PDELTA** Input increased by more then the positive delta.

6.34.2.2 enum IO_OBJID

Object dictionary ID values used on standard I/O modules.

Enumerator

- IOOBJID_DIN_8_VALUE** 8-bit digital input value
- IOOBJID_DIN_8_POL** 8-bit digital input polarity
- IOOBJID_DIN_8_FILT** 8-bit digital input filter constant
- IOOBJID_DIN_INTENA** Digital input interrupt enable.
- IOOBJID_DIN_8_MASK_ANY** 8-bit digital input int mask, any change
- IOOBJID_DIN_8_MASK_L2H** 8-bit digital input int mask, low to high
- IOOBJID_DIN_8_MASK_H2L** 8-bit digital input int mask, high to low

IOBJID_DIN_1_VALUE 1-bit digital input value
IOBJID_DIN_1_POL 1-bit digital input polarity
IOBJID_DIN_1_FILT 1-bit digital input filter constant
IOBJID_DIN_1_MASK_ANY 1-bit digital input int mask, any change
IOBJID_DIN_1_MASK_L2H 1-bit digital input int mask, low to high
IOBJID_DIN_1_MASK_H2L 1-bit digital input int mask, high to low
IOBJID_DIN_16_VALUE 16-bit digital input value
IOBJID_DIN_16_POL 16-bit digital input polarity
IOBJID_DIN_16_FILT 16-bit digital input filter constant
IOBJID_DIN_16_MASK_ANY 16-bit digital input int mask, any change
IOBJID_DIN_16_MASK_L2H 16-bit digital input int mask, low to high
IOBJID_DIN_16_MASK_H2L 16-bit digital input int mask, high to low
IOBJID_DIN_32_VALUE 32-bit digital input value
IOBJID_DIN_32_POL 32-bit digital input polarity
IOBJID_DIN_32_FILT 32-bit digital input filter constant
IOBJID_DIN_32_MASK_ANY 32-bit digital input int mask, any change
IOBJID_DIN_32_MASK_L2H 32-bit digital input int mask, low to high
IOBJID_DIN_32_MASK_H2L 32-bit digital input int mask, high to low
IOBJID_DOUT_8_VALUE 8-bit digital output value
IOBJID_DOUT_8_POL 8-bit digital output polarity
IOBJID_DOUT_8_ERRMODE 8-bit digital output error mode
IOBJID_DOUT_8_ERRVAL 8-bit digital output error value
IOBJID_DOUT_8_FILT 8-bit digital output filter mask
IOBJID_DOUT_1_VALUE 1-bit digital output value
IOBJID_DOUT_1_POL 1-bit digital output polarity
IOBJID_DOUT_1_ERRMODE 1-bit digital output error mode
IOBJID_DOUT_1_ERRVAL 1-bit digital output error value
IOBJID_DOUT_1_FILT 1-bit digital output filter mask
IOBJID_DOUT_16_VALUE 16-bit digital output value
IOBJID_DOUT_16_POL 16-bit digital output polarity
IOBJID_DOUT_16_ERRMODE 16-bit digital output error mode
IOBJID_DOUT_16_ERRVAL 16-bit digital output error value
IOBJID_DOUT_16_FILT 16-bit digital output filter mask
IOBJID_DOUT_32_VALUE 32-bit digital output value
IOBJID_DOUT_32_POL 32-bit digital output polarity
IOBJID_DOUT_32_ERRMODE 32-bit digital output error mode
IOBJID_DOUT_32_ERRVAL 32-bit digital output error value
IOBJID_DOUT_32_FILT 32-bit digital output filter mask
IOBJID_AIN_8_VALUE 8-bit analog input value
IOBJID_AIN_16_VALUE 16-bit analog input value
IOBJID_AIN_32_VALUE 32-bit analog input value
IOBJID_AIN_FLT_VALUE floating point analog input value

IOOBJID_AIN_MFG_VALUE manufacturer specific analog input value
IOOBJID_AOUT_8_VALUE 8-bit analog output value
IOOBJID_AOUT_16_VALUE 16-bit analog output value
IOOBJID_AOUT_32_VALUE 32-bit analog output value
IOOBJID_AOUT_FLT_VALUE floating point analog output value
IOOBJID_AOUT_MFG_VALUE manufacturer specific analog output value
IOOBJID_AIN_TRIG Analog input trigger selection.
IOOBJID_AIN_INTSRC Analog input interrupt source.
IOOBJID_AIN_INTENA Analog input interrupt enable.
IOOBJID_AIN_32_UPLIM 32-bit analog input upper limit
IOOBJID_AIN_32_LWLIM 32-bit analog input lower limit
IOOBJID_AIN_32_UDELTA 32-bit analog input unsigned delta
IOOBJID_AIN_32_NDELTA 32-bit analog input negative delta
IOOBJID_AIN_32_PDELTA 32-bit analog input positive delta
IOOBJID_AIN_FLT_UPLIM floating point analog input upper limit
IOOBJID_AIN_FLT_LWLIM floating point analog input lower limit
IOOBJID_AIN_FLT_UDELTA floating point analog input unsigned delta
IOOBJID_AIN_FLT_NDELTA floating point analog input negative delta
IOOBJID_AIN_FLT_PDELTA floating point analog input positive delta
IOOBJID_AIN_FLT_OFFSET floating point analog input offset
IOOBJID_AIN_FLT_SCALE floating point analog input scaling
IOOBJID_AIN_UNIT analog input SI Unit
IOOBJID_AIN_32_OFFSET 32-bit analog input offset
IOOBJID_AIN_32_SCALE 32-bit analog input scaling
IOOBJID_AOUT_FLT_OFFSET floating point analog output offset
IOOBJID_AOUT_FLT_SCALE floating point analog output scaling
IOOBJID_AOUT_ERRMODE analog output error mode
IOOBJID_AOUT_32_ERRVAL 32-bit analog output error value
IOOBJID_AOUT_FLT_ERRVAL floating point analog output error value
IOOBJID_AOUT_32_OFFSET 32-bit analog output offset
IOOBJID_AOUT_32_SCALE 32-bit analog output scaling
IOOBJID_AOUT_UNIT analog output SI Unit

6.34.2.3 enum IOMODULE_EVENTS

This enumeration gives the various events that can be waited on.

The default events are simply the reception of one of the standard transmit [PDO](#) objects.

Enumerator

IOEVENT_DIN_PDO0 Digital input [PDO](#) 0 was received. By default, this [PDO](#) is transmitted by the module when any of the first 64 digital inputs changes state.

IOEVENT_AIN_PDO0 Analog input **PDO 0** was received. By default, this **PDO** is transmitted by the module when any of the first 4 16-bit analog inputs generates an event.

There are many different types of events that are programmable for analog inputs, however not all I/O module manufacturers support all (or any) of these events. The function `IOmodule::AinSetTrigType` can be used to set the type of event associated with an analog input.

Consult the documentation provided with the I/O module to determine what types of analog input events are available for your module.

IOEVENT_AIN_PDO1 Analog input **PDO 1** was received. This **PDO** is similar to analog input **PDO 0**, however it maps the second group of 4 16-bit analog inputs.

IOEVENT_AIN_PDO2 Analog input **PDO 2** was received. This **PDO** is similar to analog input **PDO 0**, however it maps the third group of 4 16-bit analog inputs.

6.35 CML_Linkage.h File Reference

This file defines the [Linkage](#) object.

Include dependency graph for `CML_Linkage.h`:

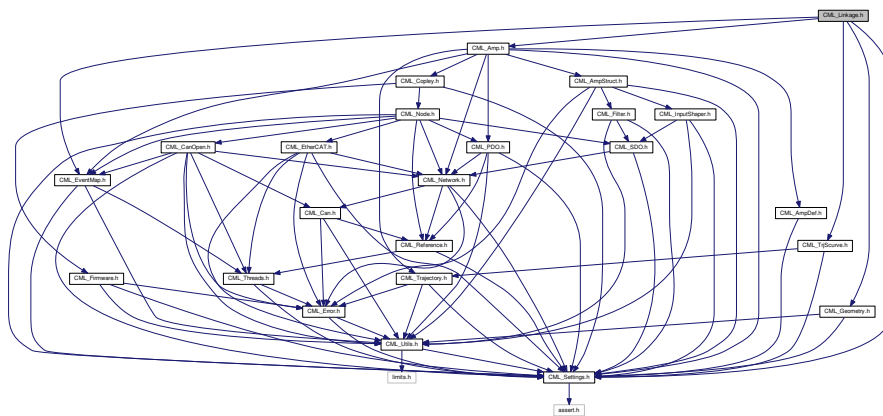

This graph shows which files directly or indirectly include this file:

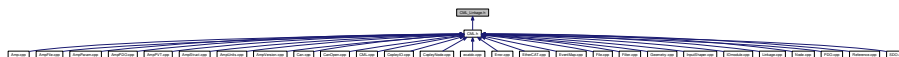

Classes

- class [LinkError](#)
This class represents error conditions that can occur in the [Linkage](#) class.
- class [RPDO_LinkCtrl](#)
*Receive **PDO** used to update the control word of all amplifiers in the linkage.*
- class [LinkSettings](#)
[Linkage](#) object settings.
- class [Linkage](#)
[Linkage](#) object, used for controlling a group of coordinated amplifiers.

Enumerations

- enum `LINK_EVENT` {
 - `LINKEVENT_MOVEDONE` = 0x00000001,
 - `LINKEVENT_TRJDONE` = 0x00000002,
 - `LINKEVENT_NODEGUARD` = 0x00000004,
 - `LINKEVENT_FAULT` = 0x00000010,
 - `LINKEVENT_ERROR` = 0x00000020,
 - `LINKEVENT_POSWARN` = 0x00000040,
 - `LINKEVENT_POSWIN` = 0x00000080,
 - `LINKEVENT_VELWIN` = 0x00000100,
 - `LINKEVENT_DISABLED` = 0x00000200,
 - `LINKEVENT_POSLIM` = 0x00000400,
 - `LINKEVENT_NEGLIM` = 0x00000800,
 - `LINKEVENT_SOFTLIM_POS` = 0x00001000,
 - `LINKEVENT_SOFTLIM_NEG` = 0x00002000,
 - `LINKEVENT_QUICKSTOP` = 0x00004000,
 - `LINKEVENT_ABORT` = 0x00008000 }

Linkage events.

6.35.1 Detailed Description

This file defines the [Linkage](#) object. A linkage is a group of two or more amplifiers which work together.

6.35.2 Enumeration Type Documentation

6.35.2.1 enum `LINK_EVENT`

[Linkage](#) events.

This enumeration provides a list of events that can be used to wait on linkage conditions.

In general, linkage events parallel the amplifier events of all of the amplifiers attached to the linkage. For example, if any of the amplifiers is reporting an error event, then the linkage will be reporting an error event.

Enumerator

`LINKEVENT_MOVEDONE` Set when all amplifiers attached to this linkage have finished their moves and have settled in to position at the end of the move. Cleared when a new move is started on any amplifier.

`LINKEVENT_TRJDONE` Set when all amplifiers attached to the linkage have finished their moves, but have not yet settled into position at the end of the move. Cleared when a new move is on any amplifier started.

`LINKEVENT_NODEGUARD` A node guarding (or heartbeat) error has occurred. This indicates that one of the amplifiers failed to respond within the expected amount of time for either a heartbeat or node guarding message.

`LINKEVENT_FAULT` A latching fault has occurred on one of the amplifiers attached to this linkage.

`LINKEVENT_ERROR` A non-latching error has occurred on one of the amplifiers.

`LINKEVENT_POSWARN` One of the the amplifiers is reporting a position warning event.

`LINKEVENT_POSWIN` One of the amplifiers is reporting a position window event.

`LINKEVENT_VELWIN` One of the amplifiers is reporting a velocity window event.

`LINKEVENT_DISABLED` One of the amplifiers is currently disabled.

`LINKEVENT_POSLIM` The positive limit switch of one or more amplifier is currently active.

LINKEVENT_NEGLIM The negative limit switch of one or more amplifier is currently active.

LINKEVENT_SOFTLIM_POS The positive software limit of one or more amplifier is currently active.

LINKEVENT_SOFTLIM_NEG The negative software limit of one or more amplifier is currently active.

LINKEVENT_QUICKSTOP One of the linkage amplifiers is presently performing a quick stop sequence or is holding in quick stop mode. The amplifier must be disabled to clear this.

LINKEVENT_ABORT One or more amplifier aborted the last profile without finishing.

6.36 CML_Network.h File Reference

This header file defines the classes used for the generic top level network interface.

Include dependency graph for CML_Network.h:

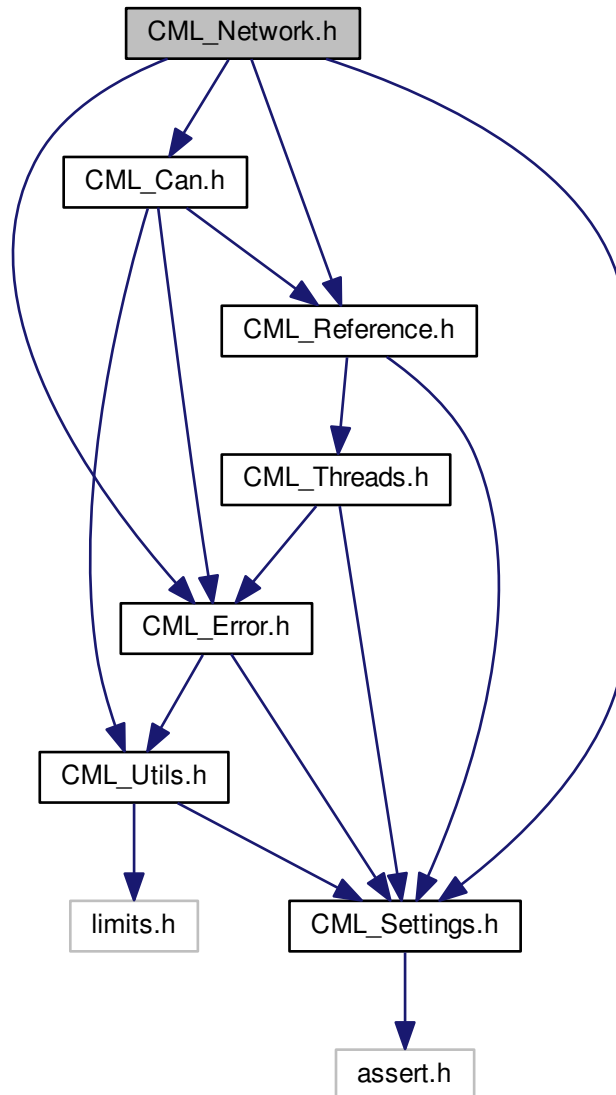

This graph shows which files directly or indirectly include this file:

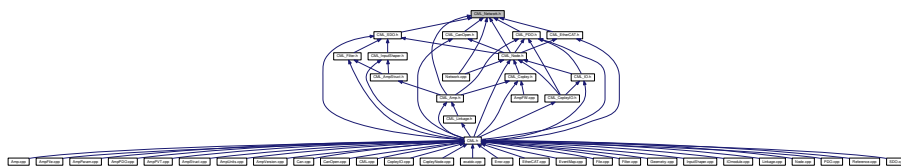

Classes

- class [NetworkError](#)
This class holds the error codes that describe various Network error conditions.
- class [NetworkNodeInfo](#)
Private data owned by the network object attached to every node.
- class [Network](#)
Abstract network class.

Enumerations

- enum [NodeState](#) {
NODESTATE_INVALID,
NODESTATE_UNKNOWN,
NODESTATE_GUARDERR,
NODESTATE_STOPPED,
NODESTATE_PRE_OP,
NODESTATE_OPERATIONAL,
NODESTATE_SAFE_OP }
Enumeration used to identify a network node state.
- enum [NetworkType](#) {
NET_TYPE_CANOPEN,
NET_TYPE_ETHERCAT,
NET_TYPE_INVALID }
Enumeration used to identify a type of network architecture.
- enum [GuardProtocol](#) {
GUARDTYPE_NONE,
GUARDTYPE_HEARTBEAT,
GUARDTYPE_NODEGUARD }
Enumeration used to identify the various types of node guarding protocols.

6.36.1 Detailed Description

This header file defines the classes used for the generic top level network interface.

6.36.2 Enumeration Type Documentation

6.36.2.1 enum [GuardProtocol](#)

Enumeration used to identify the various types of node guarding protocols.

Enumerator

GUARDTYPE_NONE No guarding protocol is in use.

GUARDTYPE_HEARTBEAT The heartbeat protocol is being used.

GUARDTYPE_NODEGUARD [Node](#) guarding protocol is being used.

6.36.2.2 enum NetworkType

Enumeration used to identify a type of network architecture.

Enumerator

- NET_TYPE_CANOPEN** CANopen network.
- NET_TYPE_ETHERCAT** EtherCAT network.
- NET_TYPE_INVALID** Invalid network type.

6.36.2.3 enum NodeState

Enumeration used to identify a network node state.

Enumerator

- NODESTATE_INVALID** Invalid node state.
- NODESTATE_UNKNOWN** Unknown state - the default state on node creation. The state will be changed when communication with the node is established.
- NODESTATE_GUARDERR** On a node guarding or heartbeat timeout, the state will change to guard error.
- NODESTATE_STOPPED** Stopped state (aka init state for EtherCAT)
- NODESTATE_PRE_OP** Pre-operational state.
- NODESTATE_OPERATIONAL** Operational state.
- NODESTATE_SAFE_OP** Safe-operational state.

6.37 CML_Node.h File Reference

This header file defines the classes that define a generic node on the network.

Include dependency graph for CML_Node.h:

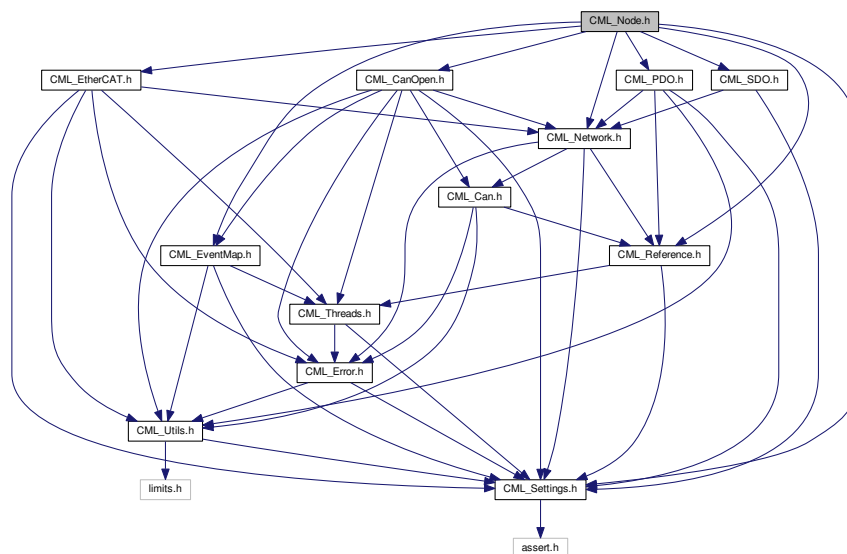

This graph shows which files directly or indirectly include this file:



Classes

- class [NodeError](#)

This class represents node errors.

- struct [NodeIdentity](#)

CANopen identity object.

- class [Node](#)

Node class.

6.37.1 Detailed Description

This header file defines the classes that define a generic node on the network.

6.38 CML_PDO.h File Reference

This header file defines the classes used to communicate to CANopen nodes using Process Data Objects (PDOs).

Include dependency graph for CML_PDO.h:

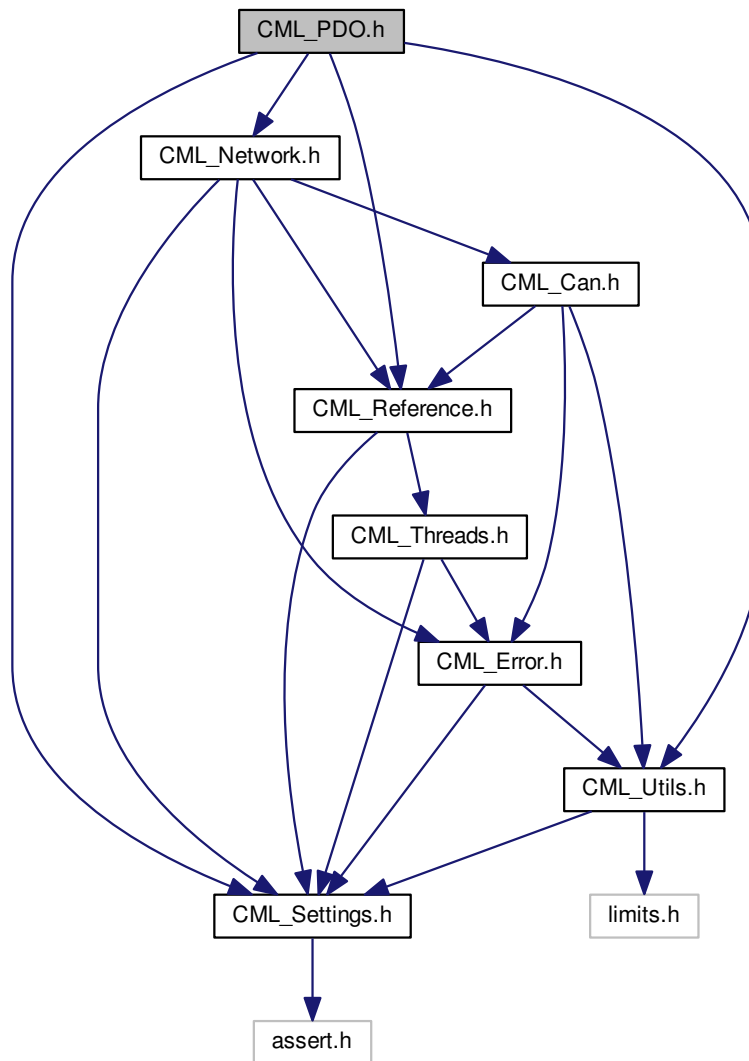

This graph shows which files directly or indirectly include this file:

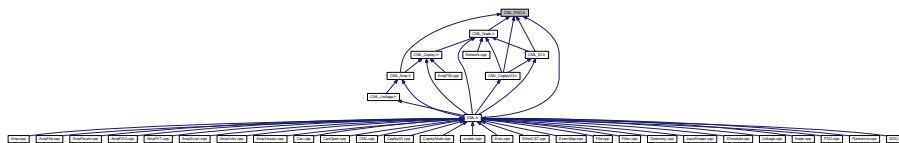

Classes

- class [PDO_Error](#)

This class represents error conditions related to PDOs.

- class [Pmap](#)

This class allows variables to be mapped into a [PDO](#).

- class [PmapRaw](#)

This is the most generic [PDO](#) variable mapping class.

- class [Pmap32](#)

This is a [PDO](#) variable mapping class that extends the virtual [Pmap](#) class to handle 32-bit integers.

- class [Pmap24](#)

This is a [PDO](#) variable mapping class that extends the virtual [Pmap](#) class to handle 24-bit integers.

- class [Pmap16](#)

This is a [PDO](#) variable mapping class that extends the virtual [Pmap](#) class to handle 16-bit integers.

- class [Pmap8](#)

This is a [PDO](#) variable mapping class that extends the virtual [Pmap](#) class to handle 8-bit integers.

- class [PDO](#)

[PDO](#) (Process Data Object) base class.

- class [TPDO](#)

Transmit [PDO](#) (transmitted by node, received by this software).

- class [RPDO](#)

Receive [PDO](#) (received by node, transmitted by this software).

Macros

- #define [PDO_MAP_LEN](#) 32

Number of variables that may be added to a [PDO](#)'s map.

- #define [FLG_RTR_OK](#) 0x01

Flag used by transmit [PDO](#)s to indicate that RTR requests are allowed.

6.38.1 Detailed Description

This header file defines the classes used to communicate to CANopen nodes using Process Data Objects (PDOs).

6.39 CML_Reference.h File Reference

This header file defines a set of classes used to handle reference counting within the CML library.

Include dependency graph for CML_Reference.h:

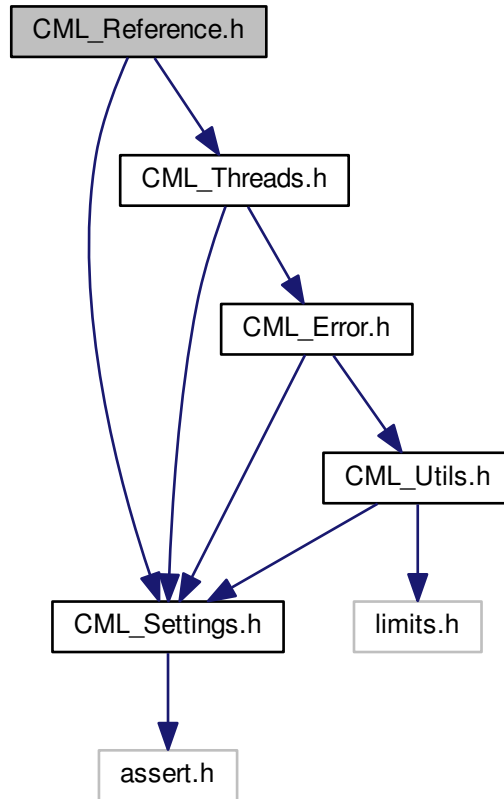

This graph shows which files directly or indirectly include this file:

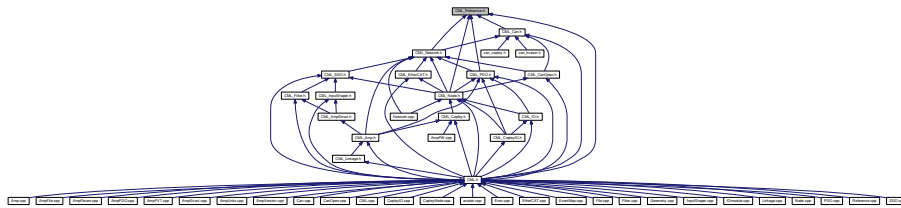

Classes

- class [RefObj](#)

This class is used to track object references in the CML library.

- class [RefObjLocker](#)< [RefClass](#) >

This is a utility class that locks a reference in it's constructor, and unlocks it in it's destructor.

6.39.1 Detailed Description

This header file defines a set of classes used to handle reference counting within the CML library.

6.40 CML_SDO.h File Reference

This header file defines the classes used to communicate to CANopen nodes using Service Data Objects (SDOs).

Include dependency graph for CML_SDO.h:

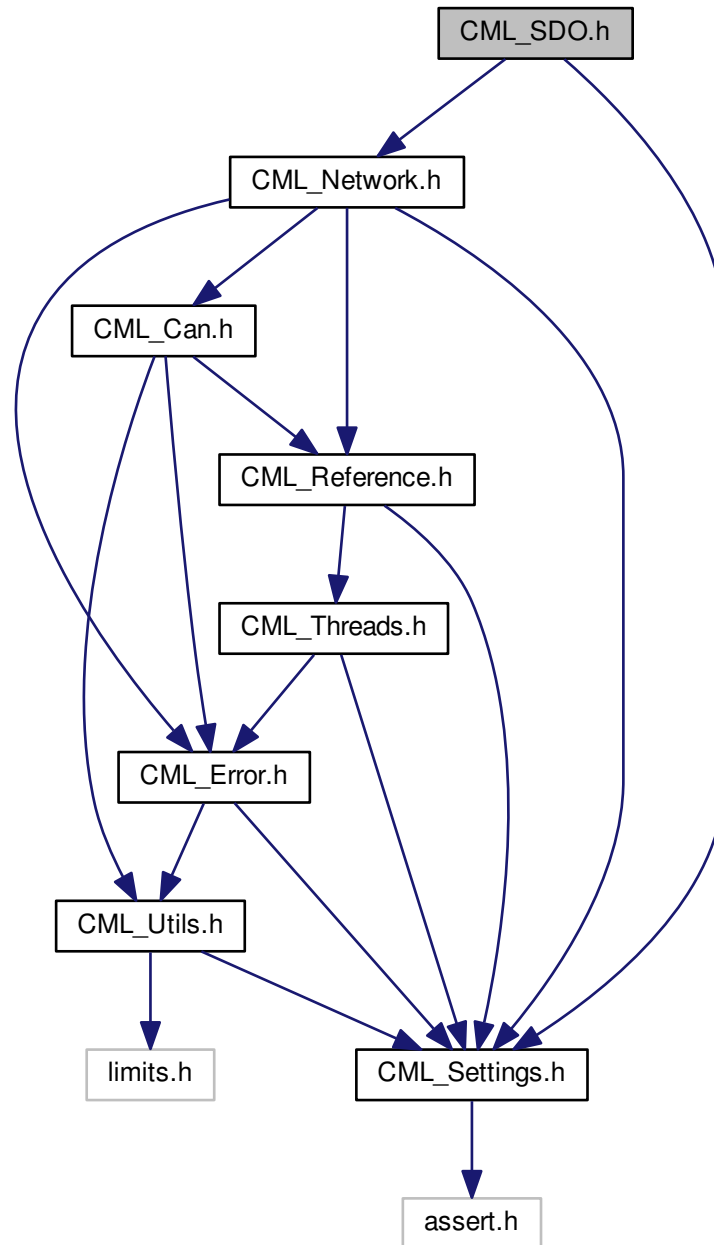

This graph shows which files directly or indirectly include this file:

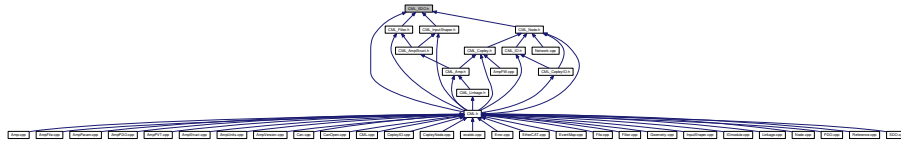

Classes

- class [SDO_Error](#)
This class represents [SDO](#) errors.
- class [SDO](#)
CANopen Service Data Object ([SDO](#)).

Macros

- `#define SDO_BLK_DNLD_THRESHOLD 15`
[SDO](#) downloads of this size (byte) or greater are more efficiently handled using a block download.
- `#define SDO_BLK_UPLD_THRESHOLD 15`
[SDO](#) uploads of this size (byte) or greater are more efficiently handled using a block upload.

6.40.1 Detailed Description

This header file defines the classes used to communicate to CANopen nodes using Service Data Objects (SDOs).

6.40.2 Macro Definition Documentation

6.40.2.1 `#define SDO_BLK_DNLD_THRESHOLD 15`

[SDO](#) downloads of this size (byte) or greater are more efficiently handled using a block download.

6.40.2.2 `#define SDO_BLK_UPLD_THRESHOLD 15`

[SDO](#) uploads of this size (byte) or greater are more efficiently handled using a block upload.

6.41 CML_Settings.h File Reference

This file provides some configuration options used to customize the Copley Motion Libraries.

Include dependency graph for CML_Settings.h:

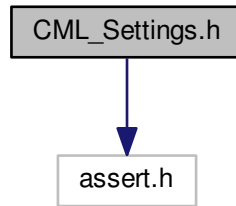

This graph shows which files directly or indirectly include this file:

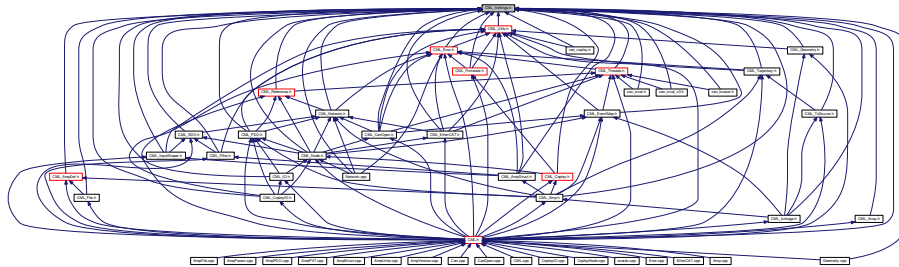

Macros

- #define `CML_NAMESPACE` `CML`
Library namespace.
- #define `CML_HASH_SIZE` `1483`
Size of the hash table used to associate CAN messages with their receivers.
- #define `CML_FILE_ACCESS_OK`
Enable file access.
- #define `CML_ALLOW_FLOATING_POINT`
Allow use of floating point math.
- #define `CML_ENABLE_USER_UNITS`
Enable user units.
- #define `CML_DEBUG_ASSERT`
Enable debug assertions.
- #define `CML_MAX_AMPS_PER_LINK` `32`
This defines the maximum number of amplifiers that may be controlled by a single linkage object.
- #define `CML_LINKAGE_TRJ_BUFFER_SIZE` `50`
This parameter controls the size of the trajectory buffer used by the linkage object.
- #define `CML_ERROR_HASH_SIZE` `64`
Size of the hash table used by the `Error::Lookup` method.

- #define `CML_ERROR_MESSAGES`
The CML::Error object includes a text message for each error type.
- #define `CML_ENABLE_IOMODULE_PDOS`
This setting enables/disables the use of `PDO` objects within the `IOModule` class.
- #define `CML_MAX_ECAT_FRAMES` 100
Size of extra private data for the `Thread` object.
- #define `CML_NAMESPACE_START()` namespace `CML_NAMESPACE`{
Compiler native type to use for 64-bit integer.

6.41.1 Detailed Description

This file provides some configuration options used to customize the Copley Motion Libraries.

6.41.2 Macro Definition Documentation

6.41.2.1 #define CML_ALLOW_FLOATING_POINT

Allow use of floating point math.

If this is defined, double precision floating point math will be used in some areas of the libraries. These areas include trajectory generation and unit conversions. If not defined, then no floating point math will be used, but some features will be disabled.

6.41.2.2 #define CML_DEBUG_ASSERT

Enable debug assertions.

If this is defined, then some debug code will be added to the library which will use the standard C `assert()` function to test for some programming errors. Commenting this out will remove the checks. The standard C header file `assert.h` must be available if this feature is used.

6.41.2.3 #define CML_ENABLE_IOMODULE_PDOS

This setting enables/disables the use of `PDO` objects within the `IOModule` class.

The `IOModule` class is used to access standard CANopen I/O modules on the network. Normally, these modules may be accessed using fast `PDO` transfers, however in very low memory embedded systems the extra RAM required to maintain the `PDO` objects may not be available. In such situations this setting may be commented out to reduce the memory footprint of the `IOModule` class.

6.41.2.4 #define CML_ENABLE_USER_UNITS

Enable user units.

If this is defined, then all position, velocity, acceleration & jerk values will be specified in double precision floating point, and the units used for these values will be programmable. If not defined, then these parameters will all be specified as 32-bit integers using internal amplifier parameters. This is less convenient, but can be much faster for systems without a floating point processor.

6.41.2.5 `#define CML_ERROR_HASH_SIZE 64`

Size of the hash table used by the [Error::Lookup](#) method.

This may be set to zero to disable this feature. Most systems will not require this feature and can safely set this parameter to zero.

6.41.2.6 `#define CML_ERROR_MESSAGES`

The `CML::Error` object includes a text message for each error type.

If this setting is commented out then those messages will not be compiled in with the library. This can be useful for embedded environments where such messages are not used and represent a large amount of wasted memory.

6.41.2.7 `#define CML_FILE_ACCESS_OK`

Enable file access.

The libraries have some features which require the standard C library functions to open, read, and write files. Some embedded systems do not support a file system, so these features may be disabled by commenting out the define. For systems which do support the standard C file access functions, this should be enabled.

6.41.2.8 `#define CML_HASH_SIZE 1483`

Size of the hash table used to associate CAN messages with their receivers.

Larger tables give faster access, but use more memory.

The following values have been selected as good options for a typical CANopen system: 2053, 1483, 1097, 683, 409.

6.41.2.9 `#define CML_LINKAGE_TRJ_BUFFER_SIZE 50`

This parameter controls the size of the trajectory buffer used by the linkage object.

The linkage object uses this buffer when streaming multi-axis PVT profiles. If multi-axis PVT profiles are not required then setting may be commented out. Doing so will significantly reduce the size of the linkage object. If multi-axis PVTs are required, set this to the length of the buffer. A value of 50 is a reasonable choice.

6.41.2.10 `#define CML_MAX_AMPS_PER_LINK 32`

This defines the maximum number of amplifiers that may be controlled by a single linkage object.

The absolute maximum value that this can accept is 32, however it can be lowered to reduce the memory requirements of the library. This setting also limits the number of independent axes/link. Normally, the number of amps & axes is the same, but the [Linkage](#) object may be extended for conditions where this isn't true. In any case, there can be no more than this many axes/link.

6.41.2.11 `#define CML_MAX_ECOT_FRAMES 100`

Size of extra private data for the [Thread](#) object.

This setting should be left undefined for most systems. It's provided to allow greater flexibility when porting the libraries to another operating system. Size of extra private data for the [Mutex](#) object. This setting should be left undefined for

most systems. It's provided to allow greater flexibility when porting the libraries to another operating system. Size of extra private data for the [Semaphore](#) object. This setting should be left undefined for most systems. It's provided to allow greater flexibility when porting the libraries to another operating system. Number of [EtherCAT](#) frames that each [EtherCAT](#) interface can keep track of at a time.

6.41.2.12 #define CML_NAMESPACE CML

Library namespace.

This gives the name of the C++ namespace which will be used to contain the library. If no namespace is desired, just comment out the define

6.41.2.13 #define CML_NAMESPACE_START() namespace CML_NAMESPACE{

Compiler native type to use for 64-bit integer.

Normally this doesn't need to be defined, but if you're getting compiler errors related to the int64 type you can set this. Some C++ compilers support the C99 style stdint.h header which defines variables of standard sizes. Uncomment this line to use that header to define the 64-bit integer type. If this line is uncommented, then CML_INT64_TYPE is ignored.

6.42 CML_Threads.h File Reference

The classes defined in this file provide an operating system independent way of accessing multi-tasking system features.

Include dependency graph for CML_Threads.h:

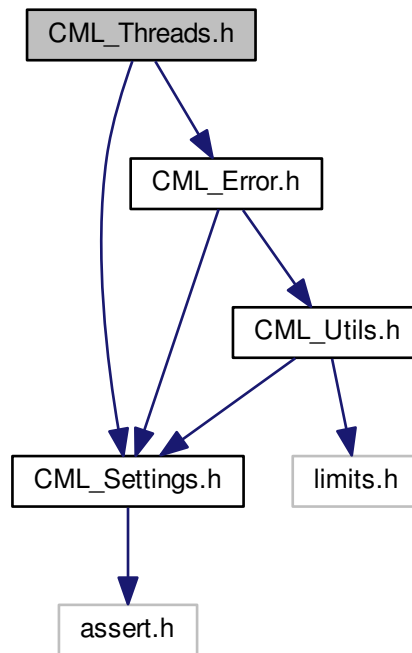

This graph shows which files directly or indirectly include this file:

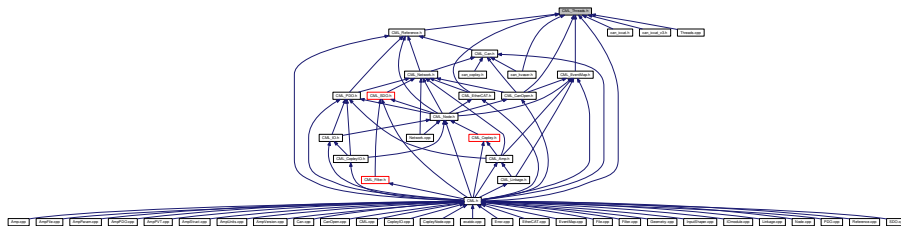

Classes

- class [ThreadError](#)
Errors related to the multi-threaded libraries.
- class [Thread](#)
Virtual class which provides multi-tasking.
- class [Mutex](#)
This class represents an object that can be used by multiple threads to gain safe access to a shared resource.
- class [MutexLocker](#)

This is a utility class that locks a mutex in it's constructor, and unlocks it in it's destructor.

- class [Semaphore](#)

Generic semaphore class.

6.42.1 Detailed Description

The classes defined in this file provide an operating system independent way of accessing multi-tasking system features. The implementation of these classes will be different for different supported platforms.

6.43 CML_Trajectory.h File Reference

Include dependency graph for CML_Trajectory.h:

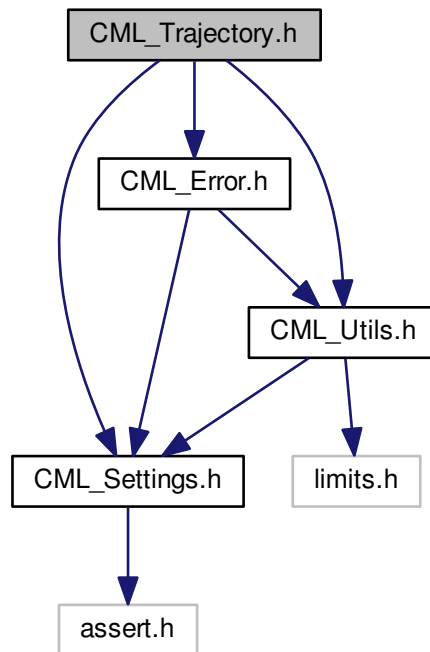

This graph shows which files directly or indirectly include this file:



Classes

- class [TrjError](#)

This class represents error conditions reported by the trajectory classes.

- class [Trajectory](#)

Trajectory information class.

- class [LinkTrajectory](#)

Linkage trajectory.

6.44 CML_TrjScurve.h File Reference

This file defines the [TrjScurve](#) class.

Include dependency graph for CML_TrjScurve.h:

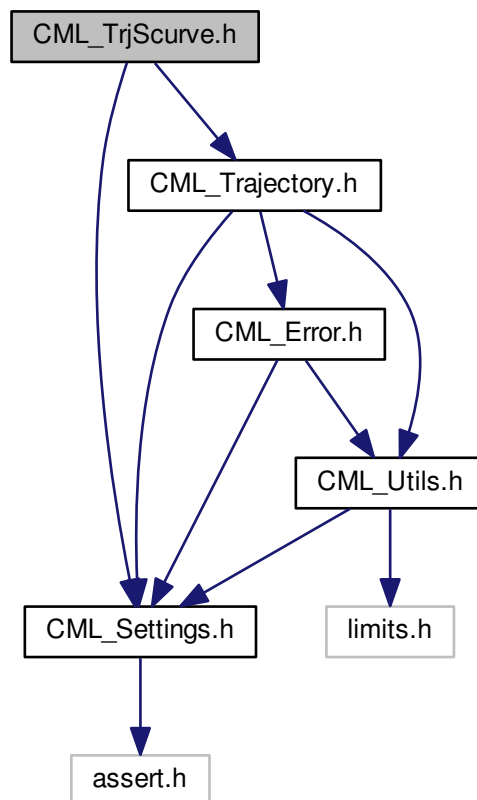

This graph shows which files directly or indirectly include this file:



Classes

- class [ScurveError](#)
This class represents error conditions that can occur in the [TrjScurve](#) class.
- class [TrjScurve](#)
Asymmetric S-curve profile generator.
- class [LinkTrjScurve](#)
Multi-axis s-curve profile.

6.44.1 Detailed Description

This file defines the [TrjScurve](#) class. This class is used to calculate asymmetric S-curve trajectory profiles for use by the [Amp](#) or [Linkage](#) objects.

6.45 CML_Utils.h File Reference

This file holds various handy utility types and functions.

Include dependency graph for CML_Utils.h:

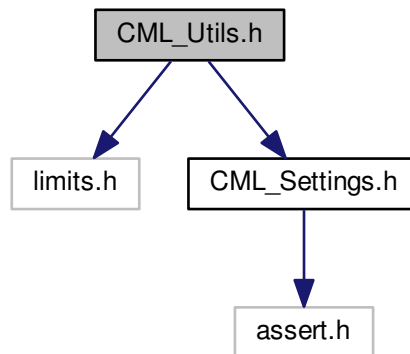

This graph shows which files directly or indirectly include this file:

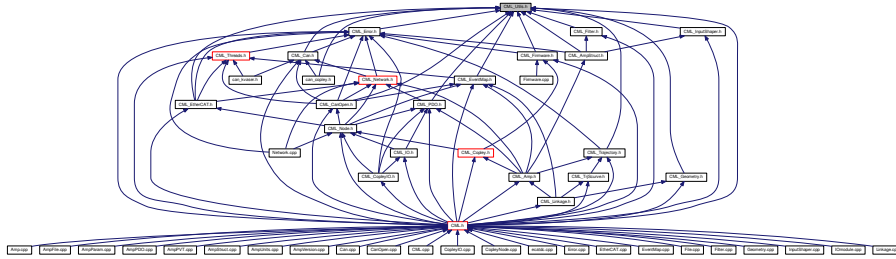

Macros

- `#define ByteCast(x) ((byte)(x))`
The `ByteCast()` macro is used to cast a value to a byte type (unsigned char).

Typedefs

- `typedef unsigned char uchar`
unsigned character
- `typedef unsigned char byte`
unsigned character
- `typedef unsigned int uint`
unsigned integer type
- `typedef unsigned long ulong`
unsigned long type
- `typedef signed char int8`
8-bit integer type
- `typedef unsigned char uint8`
8-bit unsigned integer type
- `typedef short int16`
Signed 16-bit integer type.
- `typedef unsigned short uint16`
16-bit unsigned integer type
- `typedef int int32`
Signed 32-bit integer type.
- `typedef unsigned int uint32`
Unsigned 32-bit integer type.
- `typedef CML_INT64_TYPE int64`
Signed 64-bit integer type.
- `typedef double uunit`
User programmable unit.

6.45.1 Detailed Description

This file holds various handy utility types and functions.

6.45.2 Macro Definition Documentation

6.45.2.1 #define ByteCast(x) ((byte)(x))

The [ByteCast\(\)](#) macro is used to cast a value to a byte type (unsigned char).

The reason that a macro is used rather than a simple cast is that some processors have characters that are more than 8 bits long. This is particularly common with 16-bit or 32-bit microcontrollers and DSPs. On such systems the ByteCast macro will strip off any upper bits and then cast the result to a byte. On systems with 8-bit bytes the ByteCast macro simply casts the passed value to a byte.

6.45.3 Typedef Documentation

6.45.3.1 int16

Signed 16-bit integer type.

Note that the actual definition of this type will depend on the compiler being used. The standard C language header file `limits.h` will be used to determine how to create the type definition.

6.45.3.2 int32

Signed 32-bit integer type.

Note that the actual definition of this type will depend on the compiler being used. The standard C language header file `limits.h` will be used to determine how to create the type definition.

6.45.3.3 int64

Signed 64-bit integer type.

If this isn't working correctly, check the library configuration in the file [CML_Settings.h](#)

6.45.3.4 uint16

16-bit unsigned integer type

Unsigned 16-bit integer type.

Note that the actual definition of this type will depend on the compiler being used. The standard C language header file `limits.h` will be used to determine how to create the type definition.

6.45.3.5 uint32

Unsigned 32-bit integer type.

Note that the actual definition of this type will depend on the compiler being used. The standard C language header file `limits.h` will be used to determine how to create the type definition.

6.45.3.6 uunit

User programmable unit.

If user units are enabled in the [CML_Settings.h](#) file, then this type will resolve to double precision floating point. If not, then this type will resolve to a 32-bit integer.

User units are used for all position, velocity, acceleration, and jerk values passed to/from an [Amp](#) object.

6.46 CopleyIO.cpp File Reference

This file contains the [CopleyIO](#) object methods used to upload / download structures containing groups of module parameters.

Include dependency graph for CopleyIO.cpp:

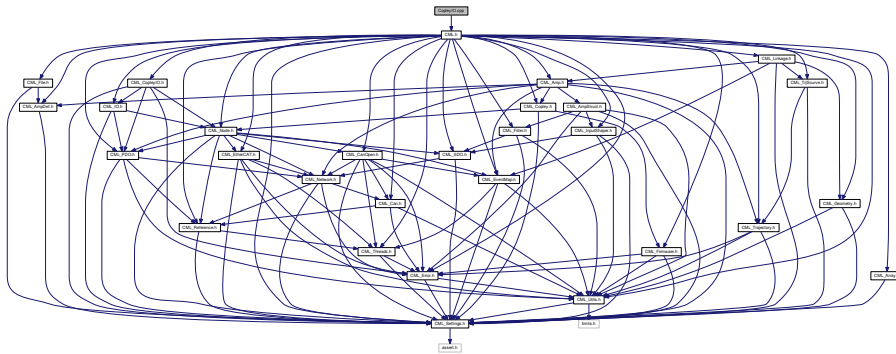

6.46.1 Detailed Description

This file contains the [CopleyIO](#) object methods used to upload / download structures containing groups of module parameters.

6.47 CopleyNode.cpp File Reference

This file holds code to implement the [CopleyNode](#) object.

Include dependency graph for CopleyNode.cpp:

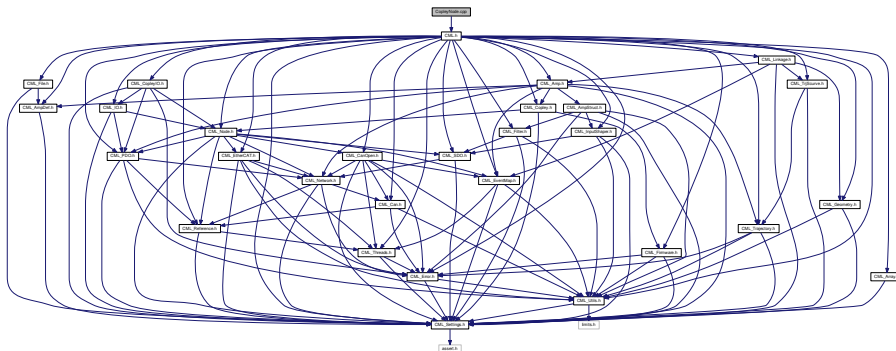

6.47.1 Detailed Description

This file holds code to implement the [CopleyNode](#) object.

6.48 ecatdc.cpp File Reference

This file holds some utility code used by the [EtherCAT](#) network when initializing it's distributed clock.

Include dependency graph for ecatdc.cpp:

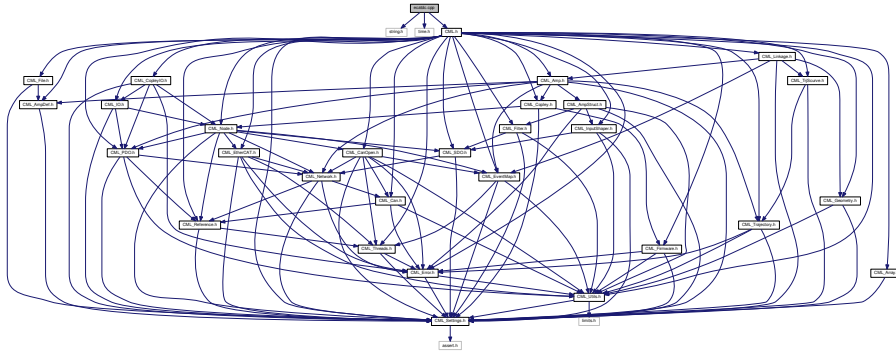

6.48.1 Detailed Description

This file holds some utility code used by the [EtherCAT](#) network when initializing it's distributed clock.

6.49 Error.cpp File Reference

This file handles initializing the static data objects used by the [Error](#) class.

Include dependency graph for Error.cpp:

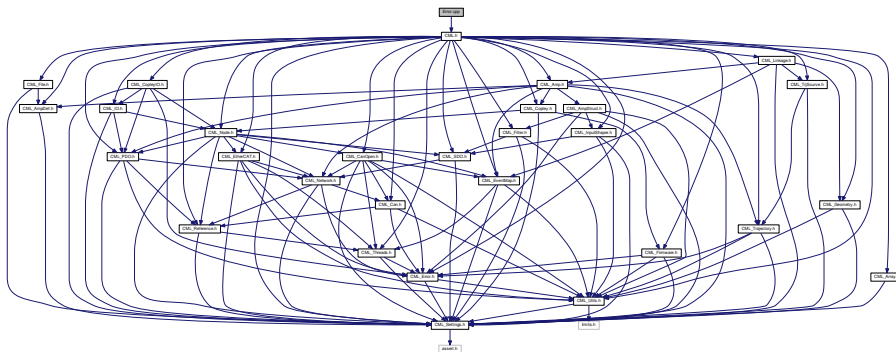

6.49.1 Detailed Description

This file handles initializing the static data objects used by the [Error](#) class.

6.50 EtherCAT.cpp File Reference

This file holds code for the top level [EtherCAT](#) class.

Include dependency graph for EtherCAT.cpp:

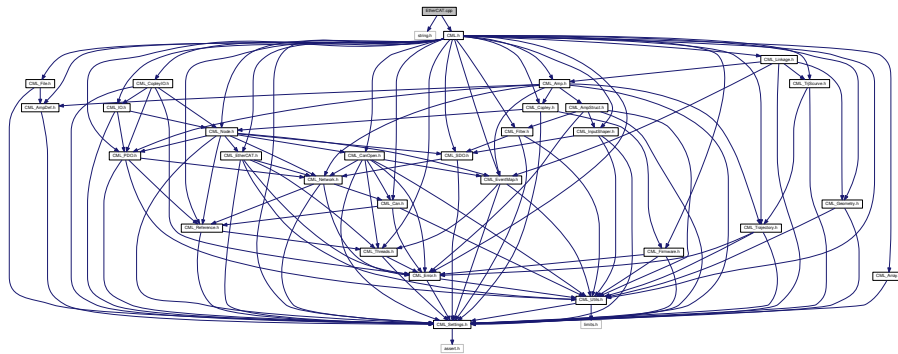

Macros

- `#define SM_RXMBX 0`

The EtherCatNodeInfo structure holds some data required by the [EtherCAT](#) network interface which is present in every node it manages.

6.50.1 Detailed Description

This file holds code for the top level [EtherCAT](#) class. This class manages the [EtherCAT](#) network.

6.50.2 Macro Definition Documentation

6.50.2.1 `#define SM_RXMBX 0`

The EtherCatNodeInfo structure holds some data required by the [EtherCAT](#) network interface which is present in every node it manages.

The contents of this structure should be considered the private property of the [EtherCAT](#) class.

6.51 EventMap.cpp File Reference

This file contains the implementation of the [EventMap](#) class.

Include dependency graph for EventMap.cpp:

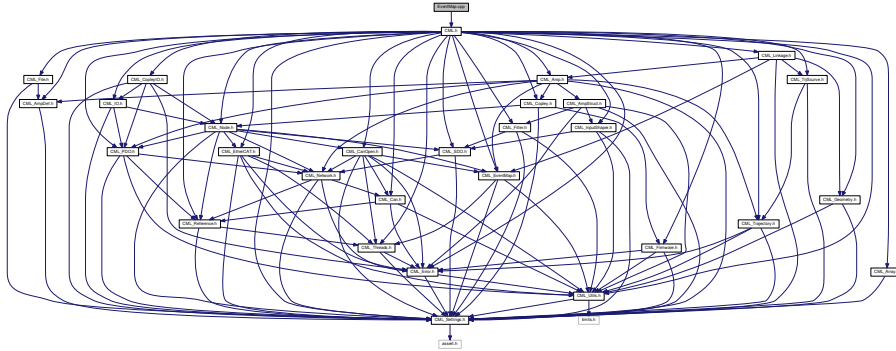

6.51.1 Detailed Description

This file contains the implementation of the [EventMap](#) class.

6.52 File.cpp File Reference

This file contains code used to parse CME-2 type files.

Include dependency graph for File.cpp:

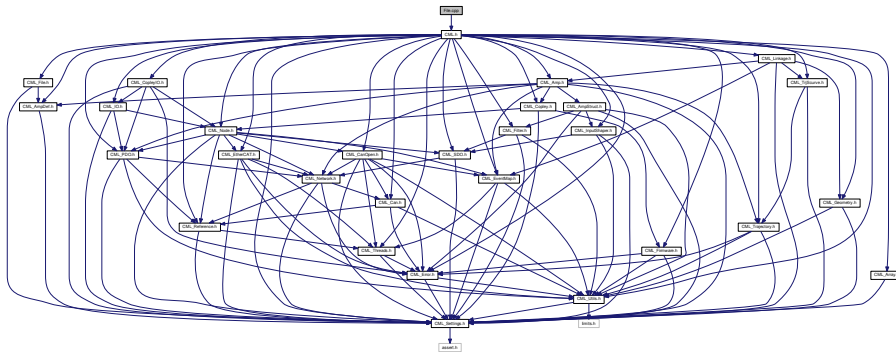

6.52.1 Detailed Description

This file contains code used to parse CME-2 type files.

6.53 Filter.cpp File Reference

Implementation of the [Filter](#) class.

6.54 Firmware.cpp File Reference

Include dependency graph for Firmware.cpp:

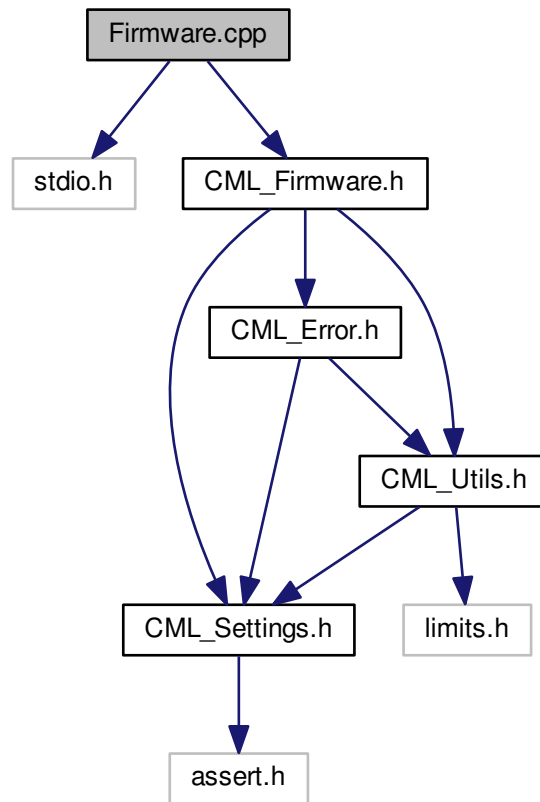

6.55 Geometry.cpp File Reference

Include dependency graph for Geometry.cpp:

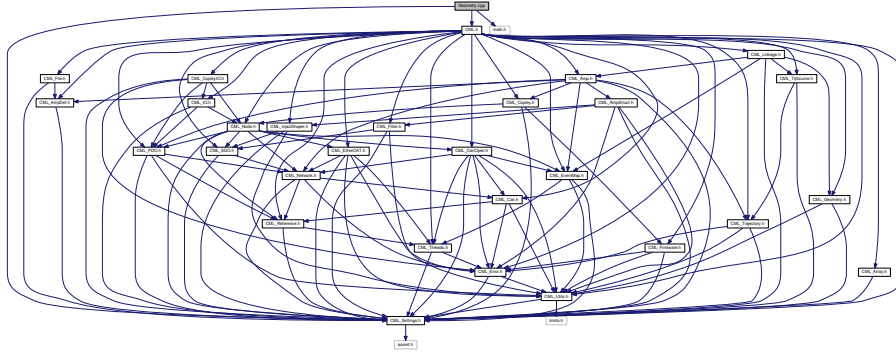

6.56 InputShaper.cpp File Reference

Implementation of the [InputShaper](#) class.

Include dependency graph for InputShaper.cpp:

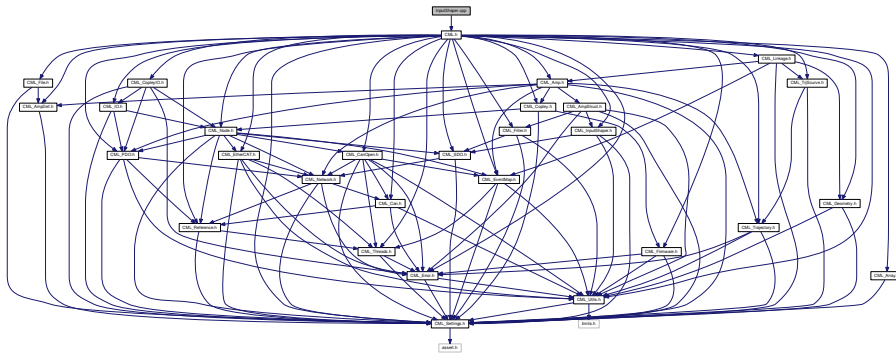

6.56.1 Detailed Description

Implementation of the [InputShaper](#) class.

6.57 IOmodule.cpp File Reference

I/O module object support.

Include dependency graph for IOModule.cpp:

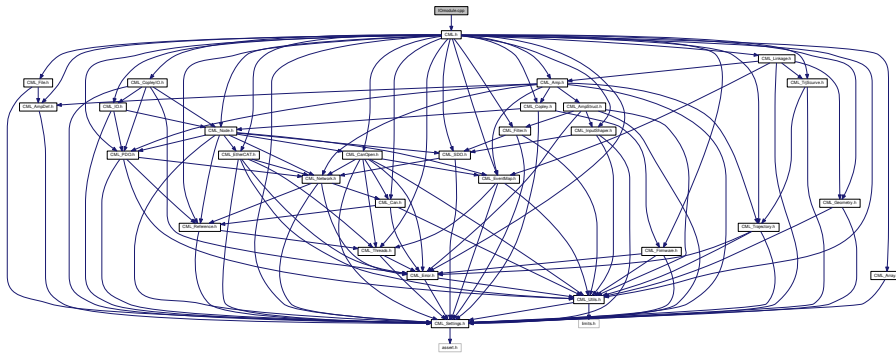

6.57.1 Detailed Description

I/O module object support. This file holds the code used to implement a standard DS401 I/O module.

6.58 Linkage.cpp File Reference

Implementation of the [Linkage](#) class.

Include dependency graph for Linkage.cpp:

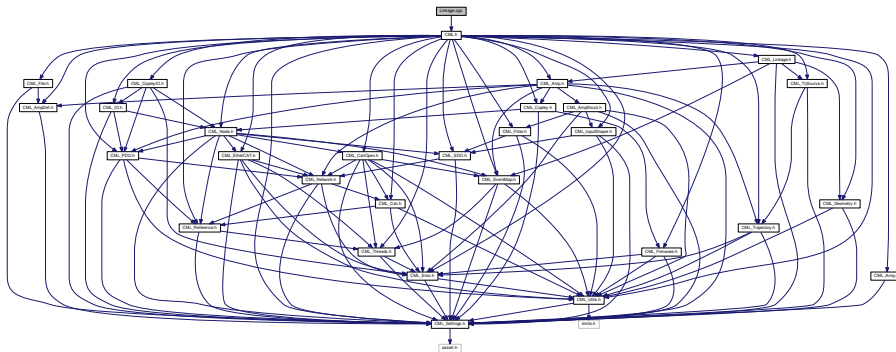

Macros

- `#define ERROR_EVENTS`

Update the status event map used by this linkage.

6.58.1 Detailed Description

Implementation of the [Linkage](#) class.

6.59 Network.cpp File Reference

This file holds code for the top level CANopen class.

Include dependency graph for Network.cpp:

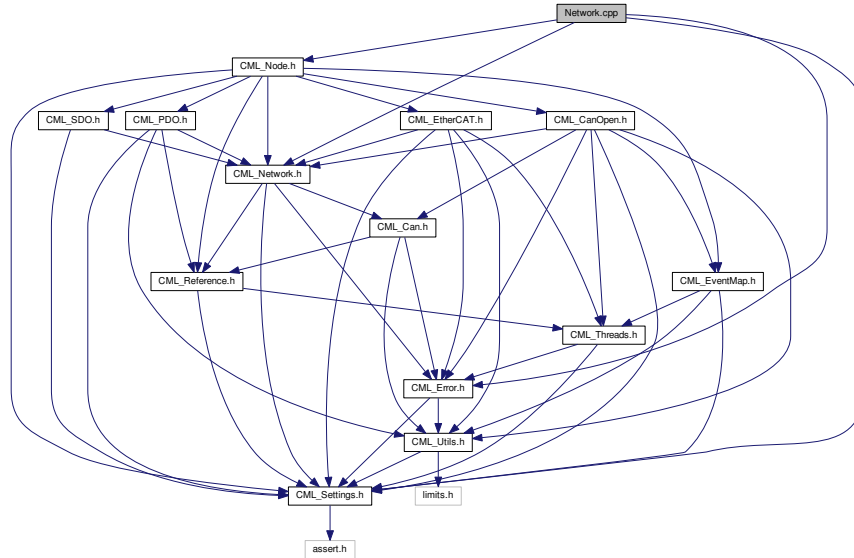

6.59.1 Detailed Description

This file holds code for the top level CANopen class. This class is used for over all control of the CANopen network.

6.60 Node.cpp File Reference

This file holds code to implement the CANopen node related objects.

Include dependency graph for Node.cpp:

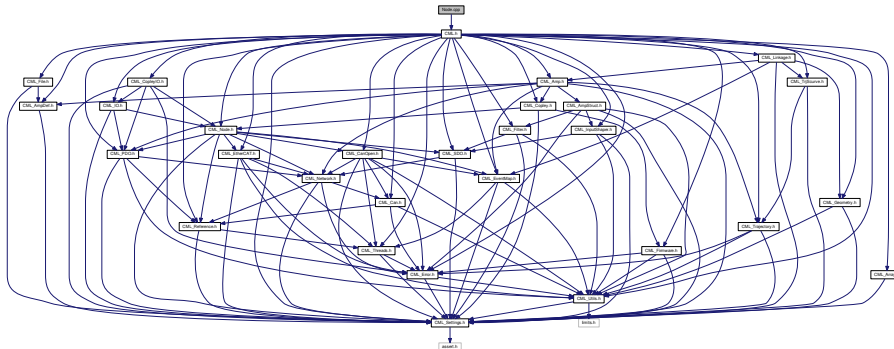

6.62.1 Detailed Description

This file holds the code needed to implement the CML reference counting objects.

6.63 SDO.cpp File Reference

This file contains the code used to implement the CANopen [SDO](#) objects.

Include dependency graph for SDO.cpp:

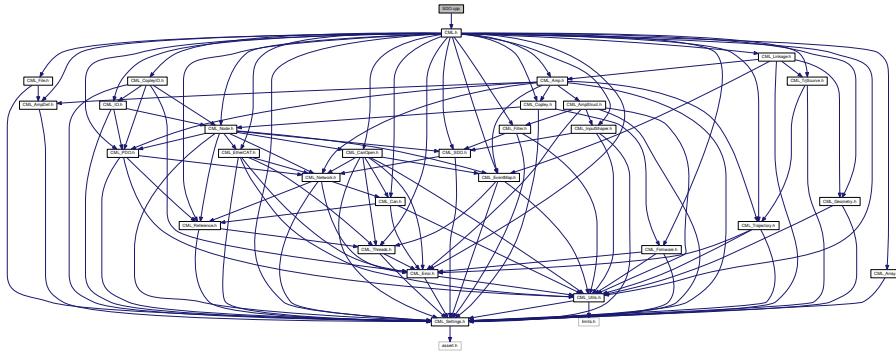

6.63.1 Detailed Description

This file contains the code used to implement the CANopen [SDO](#) objects.

6.64 Threads.cpp File Reference

This file only contains definitions for the generic thread error objects.

Include dependency graph for Threads.cpp:

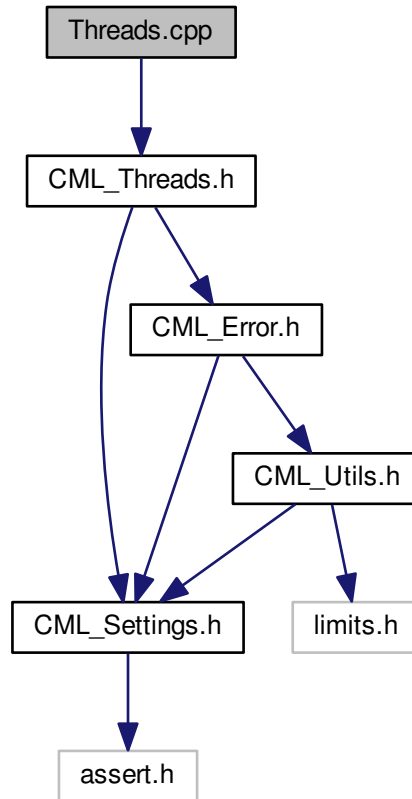

6.64.1 Detailed Description

This file only contains definitions for the generic thread error objects. The code used to implement the OS specific thread methods is located in Operating system specific files such as Threads_posix.cpp and Threads_w32.cpp.

Index

- ~CanOpen
 - CanOpen, [184](#)
- ~CopleyMotionLibrary
 - CopleyMotionLibrary, [214](#)
- ~Event
 - Event, [255](#)
- ~EventMap
 - EventMap, [266](#)
- ~IxxatCAN
 - IxxatCAN, [359](#)
- ~KvaserCAN
 - KvaserCAN, [368](#)
- ~Receiver
 - Receiver, [469](#)
- ~RefObj
 - RefObj, [471](#)
- ~Semaphore
 - Semaphore, [499](#)
- AMPEVENT_ABORT
 - CML_AmpDef.h, [549](#)
- AMPEVENT_DISABLED
 - CML_AmpDef.h, [549](#)
- AMPEVENT_ERROR
 - CML_AmpDef.h, [549](#)
- AMPEVENT_FAULT
 - CML_AmpDef.h, [549](#)
- AMPEVENT_HOME_CAPTURE
 - CML_AmpDef.h, [549](#)
- AMPEVENT_MOVEDONE
 - CML_AmpDef.h, [548](#)
- AMPEVENT_NEGLIM
 - CML_AmpDef.h, [549](#)
- AMPEVENT_NODEGUARD
 - CML_AmpDef.h, [549](#)
- AMPEVENT_NOT_INIT
 - CML_AmpDef.h, [549](#)
- AMPEVENT_PHASE_INIT
 - CML_AmpDef.h, [549](#)
- AMPEVENT_POSLIM
 - CML_AmpDef.h, [549](#)
- AMPEVENT_POSWARN
 - CML_AmpDef.h, [549](#)
- AMPEVENT_POSWIN
 - CML_AmpDef.h, [549](#)
- AMPEVENT_PVT_EMPTY
 - CML_AmpDef.h, [549](#)
- AMPEVENT_QUICKSTOP
 - CML_AmpDef.h, [549](#)
- AMPEVENT_SOFTDISABLE
 - CML_AmpDef.h, [549](#)
- AMPEVENT_SOFTLIM_NEG
 - CML_AmpDef.h, [549](#)
- AMPEVENT_SOFTLIM_POS
 - CML_AmpDef.h, [549](#)
- AMPEVENT_SPACK
 - CML_AmpDef.h, [549](#)
- AMPEVENT_TRJDONE
 - CML_AmpDef.h, [549](#)
- AMPEVENT_VELWIN
 - CML_AmpDef.h, [549](#)
- AMPMODE_AIN_CRNT
 - CML_AmpDef.h, [552](#)
- AMPMODE_AIN_VEL
 - CML_AmpDef.h, [552](#)
- AMPMODE_CAM_POS
 - CML_AmpDef.h, [552](#)
- AMPMODE_CAN_HOMING
 - CML_AmpDef.h, [551](#)
- AMPMODE_CAN_PROFILE
 - CML_AmpDef.h, [551](#)
- AMPMODE_CAN_PVT
 - CML_AmpDef.h, [552](#)
- AMPMODE_CAN_SERVO
 - CML_AmpDef.h, [552](#)
- AMPMODE_CAN_TORQUE
 - CML_AmpDef.h, [551](#)
- AMPMODE_CAN_USTEP
 - CML_AmpDef.h, [552](#)
- AMPMODE_CAN_VELOCITY
 - CML_AmpDef.h, [551](#)
- AMPMODE_DIAG_USTEP
 - CML_AmpDef.h, [552](#)
- AMPMODE_DIN_CRNT
 - CML_AmpDef.h, [552](#)
- AMPMODE_DIN_POS
 - CML_AmpDef.h, [552](#)
- AMPMODE_DIN_USTEP
 - CML_AmpDef.h, [552](#)
- AMPMODE_DIN_VEL
 - CML_AmpDef.h, [552](#)

- AMPMODE_DISABLED
 - CML_AmpDef.h, [552](#)
- AMPMODE_FGEN_CRNT
 - CML_AmpDef.h, [552](#)
- AMPMODE_FGEN_POS
 - CML_AmpDef.h, [552](#)
- AMPMODE_FGEN_USTEP
 - CML_AmpDef.h, [552](#)
- AMPMODE_FGEN_VEL
 - CML_AmpDef.h, [552](#)
- AMPMODE_PROG_CRNT
 - CML_AmpDef.h, [552](#)
- AMPMODE_PROG_VEL
 - CML_AmpDef.h, [552](#)
- AMP_EVENT
 - CML_AmpDef.h, [548](#)
- AMP_FAULT
 - CML_AmpDef.h, [549](#)
- AMP_FEATURE
 - CML_AmpDef.h, [550](#)
- AMP_MODE
 - CML_AmpDef.h, [551](#)
- AMP_PHASE_MODE
 - CML_AmpDef.h, [553](#)
- AMP_PWM_MODE
 - CML_AmpDef.h, [553](#)
- AMP_TRACE_STATUS
 - CML_AmpDef.h, [553](#)
- AMP_TRACE_VAR
 - CML_AmpDef.h, [554](#)
- APRD, [163](#)
- APWR, [164](#)
- ARMW, [165](#)
- abort
 - ProfileConfig, [461](#)
- acc
 - ProfileConfigScurve, [462](#)
 - ProfileConfigTrap, [463](#)
 - ProfileConfigVel, [464](#)
- AccLoad2User
 - Amp, [45](#)
- AccMtr2User
 - Amp, [45](#)
- AccUser2Load
 - Amp, [45](#)
- AccUser2Mtr
 - Amp, [47](#)
- accel
 - HomeConfig, [279](#)
 - SoftPosLimit, [501](#)
- Add
 - EventMap, [266](#)
- add
 - Array, [167](#)
- AddArc
 - Path, [425](#)
- AddLine
 - Path, [425](#)
- AddSegment
 - PvtSegCache, [465](#)
- AddToFrame
 - EtherCAT, [243](#)
- AddVar
 - PDO, [436](#)
- Ain16GetCt
 - IOModule, [295](#)
- Ain16GetLowerLimit
 - IOModule, [295](#)
- Ain16GetNegativeDelta
 - IOModule, [295](#)
- Ain16GetPositiveDelta
 - IOModule, [295](#)
- Ain16GetUnsignedDelta
 - IOModule, [296](#)
- Ain16GetUpperLimit
 - IOModule, [296](#)
- Ain16Read
 - IOModule, [296](#)
- Ain16SetLowerLimit
 - IOModule, [296](#)
- Ain16SetNegativeDelta
 - IOModule, [297](#)
- Ain16SetPositiveDelta
 - IOModule, [297](#)
- Ain16SetUnsignedDelta
 - IOModule, [297](#)
- Ain16SetUpperLimit
 - IOModule, [298](#)
- Ain32GetCt
 - IOModule, [298](#)
- Ain32GetLowerLimit
 - IOModule, [298](#)
- Ain32GetNegativeDelta
 - IOModule, [298](#)
- Ain32GetOffset
 - IOModule, [300](#)
- Ain32GetPositiveDelta
 - IOModule, [300](#)
- Ain32GetScaling
 - IOModule, [300](#)
- Ain32GetUnsignedDelta
 - IOModule, [300](#)
- Ain32GetUpperLimit
 - IOModule, [301](#)
- Ain32Read
 - IOModule, [301](#)
- Ain32SetLowerLimit
 - IOModule, [301](#)

- Ain32SetNegativeDelta
 - IOModule, [301](#)
- Ain32SetOffset
 - IOModule, [303](#)
- Ain32SetPositiveDelta
 - IOModule, [303](#)
- Ain32SetScaling
 - IOModule, [303](#)
- Ain32SetUnsignedDelta
 - IOModule, [303](#)
- Ain32SetUpperLimit
 - IOModule, [304](#)
- Ain8GetCt
 - IOModule, [304](#)
- Ain8Read
 - IOModule, [304](#)
- AinFltGetCt
 - IOModule, [304](#)
- AinFltGetLowerLimit
 - IOModule, [305](#)
- AinFltGetNegativeDelta
 - IOModule, [305](#)
- AinFltGetOffset
 - IOModule, [305](#)
- AinFltGetPositiveDelta
 - IOModule, [305](#)
- AinFltGetScaling
 - IOModule, [307](#)
- AinFltGetUnsignedDelta
 - IOModule, [307](#)
- AinFltGetUpperLimit
 - IOModule, [307](#)
- AinFltRead
 - IOModule, [307](#)
- AinFltSetLowerLimit
 - IOModule, [308](#)
- AinFltSetNegativeDelta
 - IOModule, [308](#)
- AinFltSetOffset
 - IOModule, [308](#)
- AinFltSetPositiveDelta
 - IOModule, [308](#)
- AinFltSetScaling
 - IOModule, [310](#)
- AinFltSetUnsignedDelta
 - IOModule, [310](#)
- AinFltSetUpperLimit
 - IOModule, [310](#)
- AinGetIntEna
 - IOModule, [310](#)
- AinGetIntSource
 - IOModule, [312](#)
- AinGetTrigType
 - IOModule, [312](#)
- AinSetIntEna
 - IOModule, [312](#)
- AinSetTrigType
 - IOModule, [312](#)
- AlgoPhaseInit, [25](#)
 - AlgoPhaseInit, [26](#)
 - AlgoPhaseInit, [26](#)
 - phaseInitConfig, [26](#)
- Amp, [29](#)
 - AccLoad2User, [45](#)
 - AccMtr2User, [45](#)
 - AccUser2Load, [45](#)
 - AccUser2Mtr, [47](#)
 - Amp, [43](#)
 - CheckStateForMove, [47](#)
 - ClearEventLatch, [47](#)
 - ClearFaults, [47](#)
 - ClearNodeGuardEvent, [48](#)
 - Disable, [48](#)
 - DnId16, [48](#), [49](#)
 - DnId32, [49](#)
 - DnId8, [49](#), [50](#)
 - DnIdString, [50](#)
 - DoMove, [50](#), [51](#)
 - Download, [52](#)
 - Enable, [52](#)
 - FormatPosInit, [52](#)
 - FormatPtSeg, [52](#)
 - FormatPvtSeg, [53](#)
 - GetAlgoPhaseInit, [53](#)
 - GetAmpConfig, [53](#)
 - GetAmpInfo, [54](#)
 - GetAmpMode, [54](#)
 - GetAmpName, [54](#)
 - GetAmpTemp, [54](#)
 - GetAnalogCommandFilter, [55](#)
 - GetAnalogEncoder, [55](#)
 - GetAnalogRefConfig, [55](#)
 - GetCammingConfig, [55](#)
 - GetCanNetworkConfig, [56](#)
 - GetControlWord, [56](#)
 - GetCountsPerUnit, [56](#)
 - GetCrntLoopConfig, [57](#)
 - GetCurrentActual, [57](#)
 - GetCurrentCommand, [57](#)
 - GetCurrentLimited, [59](#)
 - GetCurrentProgrammed, [59](#)
 - GetDAConverterConfig, [59](#)
 - GetErrorStatus, [59](#)
 - GetEventLatch, [61](#)
 - GetEventMask, [61](#)
 - GetEventStatus, [61](#)
 - GetEventSticky, [62](#)
 - GetFaultMask, [62](#)

GetFaults, 62
GetFuncGenConfig, 62
GetGainScheduling, 63
GetHallState, 63
GetHaltMode, 63
GetHighVoltage, 63
GetHomeAccel, 64
GetHomeAdjustment, 64
GetHomeCapture, 64
GetHomeConfig, 64
GetHomeCurrent, 65
GetHomeDelay, 65
GetHomeMethod, 65
GetHomeOffset, 65
GetHomeVelFast, 66
GetHomeVelSlow, 66
GetIOOptions, 69
GetIloopCommandFilter, 66
GetIloopCommandFilter2, 66
GetIndexCapture, 67
GetInputConfig, 67
GetInputDebounce, 68
GetInputShapingFilter, 69
GetInputs, 68
GetInputs32, 68
GetIoConfig, 69
GetIoPullup, 69
GetIoPullup32, 71
GetLinkRef, 71
GetLinkage, 71
GetMicrostepRate, 71
GetMotorCurrent, 72
GetMtrInfo, 72
GetNetworkOptions, 72
GetNetworkRef, 72
GetOutputConfig, 72, 74, 75
GetOutputs, 75
GetPhaseAngle, 75
GetPhaseMode, 76
GetPosCaptureCfg, 76
GetPosCaptureStat, 76
GetPosLoopConfig, 79
GetPositionActual, 76
GetPositionCommand, 78
GetPositionError, 78
GetPositionErrorWindow, 78
GetPositionLoad, 78
GetPositionMotor, 79
GetPositionWarnWindow, 79
GetProfileAcc, 80
GetProfileConfig, 80
GetProfileDec, 80
GetProfileJerk, 80
GetProfileType, 81
GetProfileVel, 81
GetPvtBuffFree, 81
GetPvtBuffStat, 81
GetPvtSegID, 82
GetPvtSegPos, 82
GetPwmInConfig, 82
GetPwmMode, 82
GetQuickStop, 83
GetQuickStopDec, 83
GetRefVoltage, 83
GetRegenConfig, 83
GetSettlingTime, 84
GetSettlingWindow, 84
GetSoftLimits, 84
GetState, 84
GetStatusWord, 85
GetTargetPos, 85
GetTargetVel, 85
GetTorqueActual, 86
GetTorqueDemand, 86
GetTorqueRated, 86
GetTorqueSlope, 86
GetTorqueTarget, 87
GetTraceChannel, 87
GetTraceData, 87
GetTraceMaxChannel, 88
GetTracePeriod, 88
GetTraceRefPeriod, 88
GetTraceStatus, 88
GetTraceTrigger, 90
GetTrackingWindows, 90
GetTrajectoryAcc, 90
GetTrajectoryVel, 91
GetUstepConfig, 91
GetVelLoopConfig, 91
GetVelocityActual, 91
GetVelocityCommand, 93
GetVelocityLimited, 93
GetVelocityLoad, 93
GetVelocityProgrammed, 94
GetVelocityWarnTime, 94
GetVelocityWarnWindow, 94
GetVloopCommandFilter, 94
GetVloopOutputFilter, 95
GetVloopOutputFilter2, 95
GetVloopOutputFilter3, 95
GoHome, 95
HaltMove, 96
HandleStateChange, 96
Init, 96, 97
InitSubAxis, 97
IsHardwareEnabled, 97
IsReferenced, 97
IsSoftwareEnabled, 98

JrkLoad2User, 98
JrkUser2Load, 98
LoadFromFile, 99
MoveAbs, 99
MoveRel, 99
PosLoad2User, 99
PosMtr2User, 100
PosUser2Load, 100
PosUser2Mtr, 100
PvtBufferFlush, 101
PvtBufferPop, 101
PvtClearErrors, 101
PvtStatusUpdate, 102
PvtWriteBuff, 102
QuickStop, 102
Relnit, 103
Reset, 103
SaveAmpConfig, 103
SendTrajectory, 103
SetAlgoPhaseInit, 105
SetAmpConfig, 105
SetAmpMode, 105
SetAmpName, 106
SetAnalogCommandFilter, 106
SetAnalogRefConfig, 106
SetCammingConfig, 106
SetCanNetworkConfig, 107
SetControlWord, 107
SetCountsPerUnit, 107, 108
SetCrntLoopConfig, 108
SetCurrentProgrammed, 108
SetDAConverterConfig, 109
SetFaultMask, 109
SetFuncGenConfig, 109
SetGainScheduling, 109
SetHaltMode, 111
SetHomeAccel, 111
SetHomeConfig, 111
SetHomeCurrent, 111
SetHomeDelay, 112
SetHomeMethod, 112
SetHomeOffset, 112
SetHomeVelFast, 113
SetHomeVelSlow, 113
SetIOOptions, 116
SetIloopCommandFilter, 113
SetIloopCommandFilter2, 113
SetInputConfig, 115
SetInputDebounce, 115
SetInputShapingFilter, 115
SetIoConfig, 116
SetIoPullup, 116
SetIoPullup32, 117
SetMicrostepRate, 117
SetMtrInfo, 117
SetNetworkOptions, 117
SetOutputConfig, 118
SetOutputs, 118
SetPhaseMode, 119
SetPosCaptureCfg, 119
SetPosLoopConfig, 121
SetPositionActual, 119
SetPositionErrorWindow, 120
SetPositionLoad, 120
SetPositionMotor, 120
SetPositionWarnWindow, 121
SetProfileAcc, 121
SetProfileConfig, 121
SetProfileDec, 122
SetProfileJerk, 122
SetProfileType, 122
SetProfileVel, 123
SetPvtInitialPos, 123
SetPwmInConfig, 123
SetPwmMode, 124
SetQuickStop, 124
SetQuickStopDec, 124
SetRegenConfig, 124
SetSettlingTime, 125
SetSettlingWindow, 125
SetSoftLimits, 125
SetTargetPos, 126
SetTargetVel, 126
SetTorqueRated, 126
SetTorqueSlope, 127
SetTorqueTarget, 127
SetTraceChannel, 127
SetTracePeriod, 127
SetTraceTrigger, 128
SetTrackingWindows, 128
SetUstepConfig, 129
SetVelLoopConfig, 130
SetVelocityProgrammed, 130
SetVelocityWarnTime, 130
SetVelocityWarnWindow, 130
SetVloopCommandFilter, 131
SetVloopOutputFilter, 131
SetVloopOutputFilter2, 131
SetVloopOutputFilter3, 131
SetupMove, 128, 129
StartMove, 133
StartPVT, 133
TraceStart, 133
TraceStop, 133
UpdateEvents, 133
Upld16, 135
Upld32, 135, 136
Upld8, 136

- UpldString, 137
- Upload, 137
- VelLoad2User, 137
- VelMtr2User, 138
- VelUser2Load, 138
- VelUser2Mtr, 138
- WaitEvent, 139
- WaitHomeDone, 139
- WaitInputEvent, 139
- WaitInputHigh, 140
- WaitInputLow, 140
- WaitMoveDone, 141
- amp
 - FuncGenConfig, 278
- Amp.cpp, 525
- AmpConfig, 141
 - CME_Config, 144
 - capCtrl, 144
 - encoderOutCfg, 145
 - limitBitMask, 145
 - options, 145
 - phaseMode, 145
 - progCrnt, 145
 - progVel, 145
 - pwmMode, 145
 - stepRate, 145
- AmpError, 146
 - DecodeStatus, 149
- AmpFW.cpp, 526
- AmpFault, 150
 - DecodeFault, 152
- AmpFile.cpp, 525
- AmpFileError, 153
- AmpInfo, 154
- AmploCfg, 156
 - AmploCfg, 157
 - AmploCfg, 157
 - inCfg, 157
 - inPullUpCfg, 157
 - inPullUpCfg32, 157
 - inputCt, 157
 - outMask, 157
 - outMask1, 157
 - outputCt, 157
- AmpPDO.cpp, 527
- AmpPVT.cpp, 528
- AmpParam.cpp, 527
- AmpSettings, 158
 - AmpSettings, 159
 - AmpSettings, 159
 - enableOnInit, 159
 - guardTime, 159
 - heartbeatPeriod, 159
 - heartbeatTimeout, 160
 - initialMode, 160
 - lifeFactor, 160
 - maxPvtSendCt, 160
 - resetOnInit, 161
 - synchID, 161
 - synchPeriod, 161
 - synchProducer, 161
 - synchUseFirstAmp, 161
 - timeStampID, 161
- AmpStruct.cpp, 528
- AmpUnits.cpp, 529
- AmpVersion.cpp, 529
- AnalogRefConfig, 162
 - calibration, 162
 - deadband, 162
 - scale, 162
- Aout16GetCt
 - IOModule, 314
- Aout16GetErrValue
 - IOModule, 314
- Aout16SetErrValue
 - IOModule, 314
- Aout16Write
 - IOModule, 314
- Aout32GetCt
 - IOModule, 316
- Aout32GetErrValue
 - IOModule, 316
- Aout32GetOffset
 - IOModule, 316
- Aout32GetScaling
 - IOModule, 316
- Aout32SetErrValue
 - IOModule, 317
- Aout32SetOffset
 - IOModule, 317
- Aout32SetScaling
 - IOModule, 317
- Aout32Write
 - IOModule, 317
- Aout8GetCt
 - IOModule, 318
- Aout8Write
 - IOModule, 318
- AoutFitGetCt
 - IOModule, 318
- AoutFitGetErrValue
 - IOModule, 318
- AoutFitGetOffset
 - IOModule, 319
- AoutFitGetScaling
 - IOModule, 319
- AoutFitSetErrValue
 - IOModule, 319

- AoutFitSetOffset
 - IOModule, 319
- AoutFitSetScaling
 - IOModule, 320
- AoutFitWrite
 - IOModule, 320
- AoutGetErrMode
 - IOModule, 320
- AoutSetErrMode
 - IOModule, 320
- Array
 - add, 167
 - Array, 167
 - length, 167
 - rem, 167
- Array< C >, 166
- AttachNode
 - CanOpen, 184
- BRD, 168
- BWR, 169
- BitCount
 - IOModule, 321
- BitDnId
 - IOModule, 321
- BitOverflow
 - PDO_Error, 439
- BitUpId
 - IOModule, 321
- BlockDnId
 - SDO, 486
- BlockUpId
 - SDO, 486
- BootModeNode
 - CanOpen, 184
- ByteCast
 - CML_Utils.h, 615
- CAN_FRAME_DATA
 - CML_Can.h, 569
- CAN_FRAME_ERROR
 - CML_Can.h, 569
- CAN_FRAME_REMOTE
 - CML_Can.h, 569
- CAN_RATE_100K
 - CML_AmpStruct.h, 566
- CAN_RATE_125K
 - CML_AmpStruct.h, 566
- CAN_RATE_1MEG
 - CML_AmpStruct.h, 566
- CAN_RATE_20K
 - CML_AmpStruct.h, 566
- CAN_RATE_250K
 - CML_AmpStruct.h, 566
- CAN_RATE_500K
 - CML_AmpStruct.h, 566
- CAN_RATE_50K
 - CML_AmpStruct.h, 566
- CAN_RATE_800K
 - CML_AmpStruct.h, 566
- CAPTURE_HIGH_SPEED_INPUT
 - CML_AmpDef.h, 562
- CAPTURE_HIGH_SPEED_INPUT_LATCH
 - CML_AmpDef.h, 562
- CAPTURE_HOME_FULL
 - CML_AmpDef.h, 562
- CAPTURE_HOME_LATCH
 - CML_AmpDef.h, 562
- CAPTURE_HOME_OVER
 - CML_AmpDef.h, 562
- CAPTURE_INDEX_FALLING
 - CML_AmpDef.h, 561
- CAPTURE_INDEX_FULL
 - CML_AmpDef.h, 562
- CAPTURE_INDEX_LATCH
 - CML_AmpDef.h, 561
- CAPTURE_INDEX_OVER
 - CML_AmpDef.h, 562
- CAPTURE_INDEX_RISING
 - CML_AmpDef.h, 561
- CHM_EXTENDED
 - CML_AmpDef.h, 558
- CHM_HARDSTOP_NEG
 - CML_AmpDef.h, 557
- CHM_HARDSTOP_ONDX_NEG
 - CML_AmpDef.h, 558
- CHM_HARDSTOP_ONDX_POS
 - CML_AmpDef.h, 557
- CHM_HARDSTOP_POS
 - CML_AmpDef.h, 557
- CHM_LHOME_INDX_NEG
 - CML_AmpDef.h, 557
- CHM_LHOME_INDX_POS
 - CML_AmpDef.h, 557
- CHM_LHOME_NEG
 - CML_AmpDef.h, 557
- CHM_LHOME_ONDX_NEG
 - CML_AmpDef.h, 557
- CHM_LHOME_ONDX_POS
 - CML_AmpDef.h, 556
- CHM_LHOME_POS
 - CML_AmpDef.h, 557
- CHM_NDX_NEG
 - CML_AmpDef.h, 557
- CHM_NDX_POS
 - CML_AmpDef.h, 557
- CHM_NHOME
 - CML_AmpDef.h, 557
- CHM_NHOME_INDX

CML_AmpDef.h, [556](#)
CHM_NHOME_ONDX
 CML_AmpDef.h, [556](#)
CHM_NLIM
 CML_AmpDef.h, [557](#)
CHM_NLIM_ONDX
 CML_AmpDef.h, [556](#)
CHM_NONE
 CML_AmpDef.h, [557](#)
CHM_PHOME
 CML_AmpDef.h, [557](#)
CHM_PHOME_INDX
 CML_AmpDef.h, [556](#)
CHM_PHOME_ONDX
 CML_AmpDef.h, [556](#)
CHM_PLIM
 CML_AmpDef.h, [557](#)
CHM_PLIM_ONDX
 CML_AmpDef.h, [556](#)
CHM_UHOME_INDX_NEG
 CML_AmpDef.h, [557](#)
CHM_UHOME_INDX_POS
 CML_AmpDef.h, [557](#)
CHM_UHOME_NEG
 CML_AmpDef.h, [557](#)
CHM_UHOME_ONDX_NEG
 CML_AmpDef.h, [557](#)
CHM_UHOME_ONDX_POS
 CML_AmpDef.h, [557](#)
CHM_UHOME_POS
 CML_AmpDef.h, [557](#)
CIOOBJID_ANLG_IABSDELTA
 CML_CopleyIO.h, [576](#)
CIOOBJID_ANLG_IFACTOR
 CML_CopleyIO.h, [576](#)
CIOOBJID_ANLG_IFLAGS
 CML_CopleyIO.h, [576](#)
CIOOBJID_ANLG_ILOLIMIT
 CML_CopleyIO.h, [576](#)
CIOOBJID_ANLG_IMASK
 CML_CopleyIO.h, [576](#)
CIOOBJID_ANLG_INEGDELTA
 CML_CopleyIO.h, [576](#)
CIOOBJID_ANLG_IOFFSET
 CML_CopleyIO.h, [576](#)
CIOOBJID_ANLG_IPOSDELTA
 CML_CopleyIO.h, [576](#)
CIOOBJID_ANLG_IRAW
 CML_CopleyIO.h, [576](#)
CIOOBJID_ANLG_ISCALED
 CML_CopleyIO.h, [576](#)
CIOOBJID_ANLG_IUPLIMIT
 CML_CopleyIO.h, [576](#)
CIOOBJID_DIGI_BANKMODE
 CML_CopleyIO.h, [575](#)
CIOOBJID_DIGI_DEBOUNCE0
 CML_CopleyIO.h, [576](#)
CIOOBJID_DIGI_DEBOUNCE1
 CML_CopleyIO.h, [576](#)
CIOOBJID_DIGI_DEBOUNCE2
 CML_CopleyIO.h, [576](#)
CIOOBJID_DIGI_DEBOUNCE3
 CML_CopleyIO.h, [576](#)
CIOOBJID_DIGI_DEBOUNCE4
 CML_CopleyIO.h, [576](#)
CIOOBJID_DIGI_DEBOUNCE5
 CML_CopleyIO.h, [576](#)
CIOOBJID_DIGI_DEBOUNCE6
 CML_CopleyIO.h, [576](#)
CIOOBJID_DIGI_DEBOUNCE7
 CML_CopleyIO.h, [576](#)
CIOOBJID_DIGI_FAULTMSK
 CML_CopleyIO.h, [575](#)
CIOOBJID_DIGI_HILOMSK
 CML_CopleyIO.h, [575](#)
CIOOBJID_DIGI_INVMSK
 CML_CopleyIO.h, [575](#)
CIOOBJID_DIGI_LOHIMSK
 CML_CopleyIO.h, [575](#)
CIOOBJID_DIGI_MODEMSK
 CML_CopleyIO.h, [575](#)
CIOOBJID_DIGI_PULLUPMSK
 CML_CopleyIO.h, [575](#)
CIOOBJID_DIGI_RAWMSK
 CML_CopleyIO.h, [575](#)
CIOOBJID_DIGI_TYPEMSK
 CML_CopleyIO.h, [575](#)
CIOOBJID_DIGI_VALUEMSK
 CML_CopleyIO.h, [575](#)
CIOOBJID_INFO_ANLGINT
 CML_CopleyIO.h, [575](#)
CIOOBJID_INFO_ANLGINTENA
 CML_CopleyIO.h, [575](#)
CIOOBJID_INFO_BAUD
 CML_CopleyIO.h, [575](#)
CIOOBJID_INFO_DIGIINTENA
 CML_CopleyIO.h, [575](#)
CIOOBJID_INFO_FWVERSION
 CML_CopleyIO.h, [575](#)
CIOOBJID_INFO_HOSTCFG
 CML_CopleyIO.h, [575](#)
CIOOBJID_INFO_HWTYPE
 CML_CopleyIO.h, [575](#)
CIOOBJID_INFO_LOOPRATE
 CML_CopleyIO.h, [575](#)
CIOOBJID_INFO_MAXWORDS
 CML_CopleyIO.h, [575](#)
CIOOBJID_INFO_MFGINFO

CML_CopleyIO.h, [575](#)
 CIOOBJID_INFO_MODEL
 CML_CopleyIO.h, [575](#)
 CIOOBJID_INFO_NAME
 CML_CopleyIO.h, [575](#)
 CIOOBJID_INFO_NODECFG
 CML_CopleyIO.h, [575](#)
 CIOOBJID_INFO_NODEID
 CML_CopleyIO.h, [575](#)
 CIOOBJID_INFO_PWMPERIODA
 CML_CopleyIO.h, [575](#)
 CIOOBJID_INFO_PWMPERIODB
 CML_CopleyIO.h, [575](#)
 CIOOBJID_INFO_RATE
 CML_CopleyIO.h, [575](#)
 CIOOBJID_INFO_RATECFG
 CML_CopleyIO.h, [575](#)
 CIOOBJID_INFO_SERIAL
 CML_CopleyIO.h, [575](#)
 CIOOBJID_INFO_STATUS
 CML_CopleyIO.h, [575](#)
 CIOOBJID_PWM_OFACOR
 CML_CopleyIO.h, [576](#)
 CIOOBJID_PWM_OOFFSET
 CML_CopleyIO.h, [576](#)
 CIOOBJID_PWM_ORAW
 CML_CopleyIO.h, [576](#)
 CIOOBJID_PWM_OSCALED
 CML_CopleyIO.h, [576](#)
 CML.h
 LOG_CAN, [538](#)
 LOG_DEBUG, [538](#)
 LOG_ERRORS, [538](#)
 LOG_EVERYTHING, [538](#)
 LOG_FILT_CAN, [538](#)
 LOG_NONE, [538](#)
 LOG_WARNINGS, [538](#)
 CML_AmpDef.h
 AMPEVENT_ABORT, [549](#)
 AMPEVENT_DISABLED, [549](#)
 AMPEVENT_ERROR, [549](#)
 AMPEVENT_FAULT, [549](#)
 AMPEVENT_HOME_CAPTURE, [549](#)
 AMPEVENT_MOVEDONE, [548](#)
 AMPEVENT_NEGLIM, [549](#)
 AMPEVENT_NODEGUARD, [549](#)
 AMPEVENT_NOT_INIT, [549](#)
 AMPEVENT_PHASE_INIT, [549](#)
 AMPEVENT_POSLIM, [549](#)
 AMPEVENT_POSWARN, [549](#)
 AMPEVENT_POSWIN, [549](#)
 AMPEVENT_PVT_EMPTY, [549](#)
 AMPEVENT_QUICKSTOP, [549](#)
 AMPEVENT_SOFTDISABLE, [549](#)
 AMPEVENT_SOFTLIM_NEG, [549](#)
 AMPEVENT_SOFTLIM_POS, [549](#)
 AMPEVENT_SPACK, [549](#)
 AMPEVENT_TRJDONE, [549](#)
 AMPEVENT_VELWIN, [549](#)
 AMPMODE_AIN_CRNT, [552](#)
 AMPMODE_AIN_VEL, [552](#)
 AMPMODE_CAM_POS, [552](#)
 AMPMODE_CAN_HOMING, [551](#)
 AMPMODE_CAN_PROFILE, [551](#)
 AMPMODE_CAN_PVT, [552](#)
 AMPMODE_CAN_SERVO, [552](#)
 AMPMODE_CAN_TORQUE, [551](#)
 AMPMODE_CAN_USTEP, [552](#)
 AMPMODE_CAN_VELOCITY, [551](#)
 AMPMODE_DIAG_USTEP, [552](#)
 AMPMODE_DIN_CRNT, [552](#)
 AMPMODE_DIN_POS, [552](#)
 AMPMODE_DIN_USTEP, [552](#)
 AMPMODE_DIN_VEL, [552](#)
 AMPMODE_DISABLED, [552](#)
 AMPMODE_FGEN_CRNT, [552](#)
 AMPMODE_FGEN_POS, [552](#)
 AMPMODE_FGEN_USTEP, [552](#)
 AMPMODE_FGEN_VEL, [552](#)
 AMPMODE_PROG_CRNT, [552](#)
 AMPMODE_PROG_VEL, [552](#)
 CAPTURE_HIGH_SPEED_INPUT, [562](#)
 CAPTURE_HIGH_SPEED_INPUT_LATCH, [562](#)
 CAPTURE_HOME_FULL, [562](#)
 CAPTURE_HOME_LATCH, [562](#)
 CAPTURE_HOME_OVER, [562](#)
 CAPTURE_INDEX_FALLING, [561](#)
 CAPTURE_INDEX_FULL, [562](#)
 CAPTURE_INDEX_LATCH, [561](#)
 CAPTURE_INDEX_OVER, [562](#)
 CAPTURE_INDEX_RISING, [561](#)
 CHM_EXTENDED, [558](#)
 CHM_HARDSTOP_NEG, [557](#)
 CHM_HARDSTOP_ONDX_NEG, [558](#)
 CHM_HARDSTOP_ONDX_POS, [557](#)
 CHM_HARDSTOP_POS, [557](#)
 CHM_LHOME_INDX_NEG, [557](#)
 CHM_LHOME_INDX_POS, [557](#)
 CHM_LHOME_NEG, [557](#)
 CHM_LHOME_ONDX_NEG, [557](#)
 CHM_LHOME_ONDX_POS, [556](#)
 CHM_LHOME_POS, [557](#)
 CHM_NDX_NEG, [557](#)
 CHM_NDX_POS, [557](#)
 CHM_NHOME, [557](#)
 CHM_NHOME_INDX, [556](#)
 CHM_NHOME_ONDX, [556](#)
 CHM_NLIM, [557](#)

CHM_NLIM_ONDX, 556
CHM_NONE, 557
CHM_PHOME, 557
CHM_PHOME_INDX, 556
CHM_PHOME_ONDX, 556
CHM_PLIM, 557
CHM_PLIM_ONDX, 556
CHM_UHOME_INDX_NEG, 557
CHM_UHOME_INDX_POS, 557
CHM_UHOME_NEG, 557
CHM_UHOME_ONDX_NEG, 557
CHM_UHOME_ONDX_POS, 557
CHM_UHOME_POS, 557
ESTAT_ACC_LIMIT, 558
ESTAT_AMP_TEMP, 558
ESTAT_BRAKE, 558
ESTAT_CMD_INPUT, 559
ESTAT_CRNT_LIM, 558
ESTAT_DISABLE_INPUT, 558
ESTAT_ENCODER_PWR, 558
ESTAT_FAULT, 558
ESTAT_HOME, 558
ESTAT_MOVING, 559
ESTAT_MTR_TEMP, 558
ESTAT_NEGLIM, 558
ESTAT_OVER_VOLT, 558
ESTAT_PHASE_ERR, 558
ESTAT_PHASE_INIT, 559
ESTAT_POSLIM, 558
ESTAT_POSWRAP, 558
ESTAT_PWM_DISABLE, 558
ESTAT_RESET, 558
ESTAT_SHORT_CRCT, 558
ESTAT_SOFT_DISABLE, 558
ESTAT_SOFTLIM_NEG, 558
ESTAT_SOFTLIM_POS, 558
ESTAT_STOP, 558
ESTAT_TRK_ERR, 558
ESTAT_TRK_WARN, 558
ESTAT_TRK_WIN, 558
ESTAT_UNDER_VOLT, 558
ESTAT_VEL_LIMIT, 558
ESTAT_VEL_WIN, 559
ESTAT_VOLT_LIM, 558
FAULT_ADCOFFSET, 549
FAULT_AMP_TEMP, 549
FAULT_DATAFLASH, 549
FAULT_ENCODER_PWR, 550
FAULT_I2T_ERR, 550
FAULT_MTR_TEMP, 549
FAULT_OVER_VOLT, 550
FAULT_PHASE_ERR, 550
FAULT_SHORT_CRCT, 549
FAULT_TRK_ERR, 550
FAULT_UNDER_VOLT, 550
FEATURE_AIN_FILT, 550
FEATURE_ALGO_PHASE_INIT_CONFIG, 550
FEATURE_ALGO_PHASE_INIT_CUR, 550
FEATURE_AXIS_CT, 551
FEATURE_BRAKE_ENABLE_DELAY, 551
FEATURE_CAMMING, 550
FEATURE_CAN_OPTIONS, 550
FEATURE_CAN_SETTINGS, 550
FEATURE_CURRENT_SLOPE, 550
FEATURE_DA_CONV_CONFIG, 551
FEATURE_ENC_OPTIONS, 550
FEATURE_EXTENDED_OUTPUT_PIN_CONFIG, 550
FEATURE_FLOAT_FILT_COEF, 551
FEATURE_GAIN_SCHED, 550
FEATURE_GEAR_RATIO, 550
FEATURE_HALL_VEL_SHIFT, 550
FEATURE_ILOOP_CMD_FILT, 550
FEATURE_INPUT_SHAPING, 551
FEATURE_IO_OPTIONS, 551
FEATURE_MTR_OVERTEMP, 551
FEATURE_NET_OPTIONS, 551
FEATURE_PIN_MAP, 550
FEATURE_PLOOP_KD, 551
FEATURE_PLOOP_KI, 551
FEATURE_PLOOP_SCALE, 550
FEATURE_POS_WRAP, 550
FEATURE_PWMIN_FREQ, 550
FEATURE_PWMIN_MAX_PULSE, 550
FEATURE_PWMIN_MIN_PULSE, 550
FEATURE_PWMIN_UVCFG, 551
FEATURE_RESOLVER_CYCLES, 550
FEATURE_SERVO_CONFIG, 551
FEATURE_SOFTLIM_ACCEL, 550
FEATURE_STEP_DETENT_GAIN, 550
FEATURE_STEPPER_CRNT, 550
FEATURE_USTEP_CONFIG_STATUS, 550
FEATURE_USTEP_OUTER_LOOP, 550
FEATURE_VLOOP_CMD_FILT, 550
FEATURE_VLOOP_CMDFF, 551
FEATURE_VLOOP_OUT_FILT, 550
HALT_ABRUPT, 559
HALT_DECEL, 559
HALT_DISABLE, 559
HALT_QUICKSTOP, 559
INCFG_ABORT_WINDOW_F, 560
INCFG_ABORT_WINDOW_R, 560
INCFG_CLR_FAULTS_EVENTS_F, 560
INCFG_CLR_FAULTS_EVENTS_R, 560
INCFG_CLR_FAULTS_H, 559
INCFG_CLR_FAULTS_L, 559
INCFG_COUNT_EDGES_F, 560
INCFG_COUNT_EDGES_R, 560

INCFG_DIS_SIM_ENC_H_BURST_F, 560
INCFG_DIS_SIM_ENC_L_BURST_R, 560
INCFG_DISABLE_H, 560
INCFG_DISABLE_L, 560
INCFG_ENCODER_FAULT_H, 560
INCFG_ENCODER_FAULT_L, 560
INCFG_HIGHSPEED_CAPTURE_F, 560
INCFG_HIGHSPEED_CAPTURE_R, 560
INCFG_HOME_H, 560
INCFG_HOME_L, 560
INCFG_HV_LOSS_DISABLE_H, 560
INCFG_HV_LOSS_DISABLE_L, 560
INCFG_MOTION_ABORT_H, 560
INCFG_MOTION_ABORT_L, 560
INCFG_MOTOR_TEMP_H, 559
INCFG_MOTOR_TEMP_L, 559
INCFG_NEGLIM_H, 559
INCFG_NEGLIM_L, 559
INCFG_NONE, 559
INCFG_POSLIM_H, 559
INCFG_POSLIM_L, 559
INCFG_PWM_SYNC_H, 560
INCFG_RESET_DISABLE_F, 559
INCFG_RESET_DISABLE_R, 559
INCFG_RESET_F, 559
INCFG_RESET_R, 559
INCFG_SCALE_ADC_H, 560
INCFG_SCALE_ADC_L, 560
INCFG_TRJ_UPDATE_F, 560
INCFG_TRJ_UPDATE_R, 560
OUTCFG_ACTIVE_HIGH, 561
OUTCFG_EVENT_LATCH_H, 561
OUTCFG_EVENT_LATCH_L, 561
OUTCFG_EVENT_STATUS_H, 560
OUTCFG_EVENT_STATUS_L, 560
OUTCFG_MANUAL_H, 561
OUTCFG_MANUAL_L, 561
OUTCFG_POSITION_TRIG, 561
OUTCFG_POSITION_TRIG_HIGH2LOW, 561
OUTCFG_POSITION_TRIG_LIST, 561
OUTCFG_POSITION_TRIG_LOW2HIGH, 561
OUTCFG_POSITION_WINDOW, 561
OUTCFG_SYNC_OUTPUT, 561
OUTCFG_TRJ_STATUS, 561
PHASE_MODE_AHALL90, 553
PHASE_MODE_BRUSHED, 553
PHASE_MODE_ENCODER, 553
PHASE_MODE_ENCPHASE, 553
PHASE_MODE_NOADJUST, 553
PHASE_MODE_NOHALL, 553
PHASE_MODE_TRAP, 553
PHASE_MODE_TRAPINTERP, 553
PROFILE_CSP, 563
PROFILE_SCURVE, 563
PROFILE_TRAP, 562
PROFILE_VEL, 562
PWM_MODE_AUTOCLAMP, 553
PWM_MODE_FORCECLAMP, 553
PWM_MODE_HEXLIMIT, 553
PWM_MODE_STANDARD, 553
QSTOP_ABRUPT, 563
QSTOP_ABRUPT_HOLD, 563
QSTOP_DECEL, 563
QSTOP_DECEL_HOLD, 563
QSTOP_DISABLE, 563
QSTOP_QUICKSTOP, 563
QSTOP_QUICKSTOP_HOLD, 563
TRACETRIG_ABOVE, 554
TRACETRIG_BELOW, 554
TRACETRIG_BITCLR, 554
TRACETRIG_BITSET, 554
TRACETRIG_CHANGE, 554
TRACETRIG_CHANNEL, 554
TRACETRIG_EVENTCLR, 554
TRACETRIG_EVENTSET, 554
TRACETRIG_FALL, 554
TRACETRIG_FGEN_CYCLE, 554
TRACETRIG_NODELAY, 554
TRACETRIG_NONE, 554
TRACETRIG_RISE, 554
TRACETRIG_SAMPLE, 554
TRACETRIG_TYPE, 554
TRACEVAR_ANALOG_REF, 555
TRACEVAR_CMD_ACC, 555
TRACEVAR_CMD_POS, 555
TRACEVAR_CMD_VEL, 555
TRACEVAR_CRNT_A, 555
TRACEVAR_CRNT_ACT_D, 555
TRACEVAR_CRNT_ACT_Q, 555
TRACEVAR_CRNT_B, 555
TRACEVAR_CRNT_CMD, 555
TRACEVAR_CRNT_CMD_D, 555
TRACEVAR_CRNT_CMD_Q, 555
TRACEVAR_CRNT_ERR_D, 555
TRACEVAR_CRNT_ERR_Q, 555
TRACEVAR_CRNT_LIM, 555
TRACEVAR_DEST_POS, 555
TRACEVAR_ENC_COS, 555
TRACEVAR_ENC_SIN, 555
TRACEVAR_EVENTLATCH, 555
TRACEVAR_EVENTS, 555
TRACEVAR_HALLS, 555
TRACEVAR_HIGH_VOLT, 555
TRACEVAR_INPUTS, 555
TRACEVAR_LOAD_POS, 555
TRACEVAR_MTR_POS, 555
TRACEVAR_PHASE, 555
TRACEVAR_POS_ERR, 555

- TRACEVAR_RAW_INPUTS, 555
- TRACEVAR_TEMP, 555
- TRACEVAR_VEL_LOAD, 555
- TRACEVAR_VEL_MTR, 555
- TRACEVAR_VEL_RAW, 555
- TRACEVAR_VLOOP_CMD, 555
- TRACEVAR_VLOOP_ERR, 555
- TRACEVAR_VLOOP_LIM, 555
- TRACEVAR_VOLT_D, 555
- TRACEVAR_VOLT_Q, 555
- CML_AmpStruct.h
 - CAN_RATE_100K, 566
 - CAN_RATE_125K, 566
 - CAN_RATE_1MEG, 566
 - CAN_RATE_20K, 566
 - CAN_RATE_250K, 566
 - CAN_RATE_500K, 566
 - CAN_RATE_50K, 566
 - CAN_RATE_800K, 566
- CML_Can.h
 - CAN_FRAME_DATA, 569
 - CAN_FRAME_ERROR, 569
 - CAN_FRAME_REMOTE, 569
- CML_CopleyIO.h
 - CIOOBJID_ANLG_IABSDDELTA, 576
 - CIOOBJID_ANLG_IFACTOR, 576
 - CIOOBJID_ANLG_IFLAGS, 576
 - CIOOBJID_ANLG_ILOLIMIT, 576
 - CIOOBJID_ANLG_IMASK, 576
 - CIOOBJID_ANLG_INEGDELTA, 576
 - CIOOBJID_ANLG_IOFFSET, 576
 - CIOOBJID_ANLG_IPOSDELTA, 576
 - CIOOBJID_ANLG_IRAW, 576
 - CIOOBJID_ANLG_ISCALED, 576
 - CIOOBJID_ANLG_IUPLIMIT, 576
 - CIOOBJID_DIGI_BANKMODE, 575
 - CIOOBJID_DIGI_DEBOUNCE0, 576
 - CIOOBJID_DIGI_DEBOUNCE1, 576
 - CIOOBJID_DIGI_DEBOUNCE2, 576
 - CIOOBJID_DIGI_DEBOUNCE3, 576
 - CIOOBJID_DIGI_DEBOUNCE4, 576
 - CIOOBJID_DIGI_DEBOUNCE5, 576
 - CIOOBJID_DIGI_DEBOUNCE6, 576
 - CIOOBJID_DIGI_DEBOUNCE7, 576
 - CIOOBJID_DIGI_FAULTMSK, 575
 - CIOOBJID_DIGI_HILOMSK, 575
 - CIOOBJID_DIGI_INVMSK, 575
 - CIOOBJID_DIGI_LOHIMSK, 575
 - CIOOBJID_DIGI_MODEMSK, 575
 - CIOOBJID_DIGI_PULLUPMSK, 575
 - CIOOBJID_DIGI_RAWMSK, 575
 - CIOOBJID_DIGI_TYPEMSK, 575
 - CIOOBJID_DIGI_VALUEMSK, 575
 - CIOOBJID_INFO_ANLGINT, 575
 - CIOOBJID_INFO_ANLGINTENA, 575
 - CIOOBJID_INFO_BAUD, 575
 - CIOOBJID_INFO_DIGIINTENA, 575
 - CIOOBJID_INFO_FWVERSION, 575
 - CIOOBJID_INFO_HOSTCFG, 575
 - CIOOBJID_INFO_HWTYPE, 575
 - CIOOBJID_INFO_LOOPRATE, 575
 - CIOOBJID_INFO_MAXWORDS, 575
 - CIOOBJID_INFO_MFGINFO, 575
 - CIOOBJID_INFO_MODEL, 575
 - CIOOBJID_INFO_NAME, 575
 - CIOOBJID_INFO_NODECFG, 575
 - CIOOBJID_INFO_NODEID, 575
 - CIOOBJID_INFO_PWMPERIODA, 575
 - CIOOBJID_INFO_PWMPERIODB, 575
 - CIOOBJID_INFO_RATE, 575
 - CIOOBJID_INFO_RATECFG, 575
 - CIOOBJID_INFO_SERIAL, 575
 - CIOOBJID_INFO_STATUS, 575
 - CIOOBJID_PWM_OFACTOR, 576
 - CIOOBJID_PWM_OOFFSET, 576
 - CIOOBJID_PWM_ORAW, 576
 - CIOOBJID_PWM_OSCALED, 576
- CML_IO.h
 - IOAINTRIG_LOWER_LIM, 590
 - IOAINTRIG_NDELTA, 590
 - IOAINTRIG_PDELTA, 590
 - IOAINTRIG_UDELTA, 590
 - IOAINTRIG_UPPER_LIM, 590
 - IOEVENT_AIN_PDO0, 592
 - IOEVENT_AIN_PDO1, 593
 - IOEVENT_AIN_PDO2, 593
 - IOEVENT_DIN_PDO0, 592
 - IOOBJID_AIN_16_VALUE, 591
 - IOOBJID_AIN_32_LWLIM, 592
 - IOOBJID_AIN_32_NDELTA, 592
 - IOOBJID_AIN_32_OFFSET, 592
 - IOOBJID_AIN_32_PDELTA, 592
 - IOOBJID_AIN_32_SCALE, 592
 - IOOBJID_AIN_32_UDELTA, 592
 - IOOBJID_AIN_32_UPLIM, 592
 - IOOBJID_AIN_32_VALUE, 591
 - IOOBJID_AIN_8_VALUE, 591
 - IOOBJID_AIN_FLT_LWLIM, 592
 - IOOBJID_AIN_FLT_NDELTA, 592
 - IOOBJID_AIN_FLT_OFFSET, 592
 - IOOBJID_AIN_FLT_PDELTA, 592
 - IOOBJID_AIN_FLT_SCALE, 592
 - IOOBJID_AIN_FLT_UDELTA, 592
 - IOOBJID_AIN_FLT_UPLIM, 592
 - IOOBJID_AIN_FLT_VALUE, 591
 - IOOBJID_AIN_INTENA, 592
 - IOOBJID_AIN_INTSRC, 592
 - IOOBJID_AIN_MFG_VALUE, 591

- IOOBJID_AIN_TRIG, 592
- IOOBJID_AIN_UNIT, 592
- IOOBJID_AOUT_16_VALUE, 592
- IOOBJID_AOUT_32_ERRVAL, 592
- IOOBJID_AOUT_32_OFFSET, 592
- IOOBJID_AOUT_32_SCALE, 592
- IOOBJID_AOUT_32_VALUE, 592
- IOOBJID_AOUT_8_VALUE, 592
- IOOBJID_AOUT_ERRMODE, 592
- IOOBJID_AOUT_FLT_ERRVAL, 592
- IOOBJID_AOUT_FLT_OFFSET, 592
- IOOBJID_AOUT_FLT_SCALE, 592
- IOOBJID_AOUT_FLT_VALUE, 592
- IOOBJID_AOUT_MFG_VALUE, 592
- IOOBJID_AOUT_UNIT, 592
- IOOBJID_DIN_16_FILTER, 591
- IOOBJID_DIN_16_MASK_ANY, 591
- IOOBJID_DIN_16_MASK_H2L, 591
- IOOBJID_DIN_16_MASK_L2H, 591
- IOOBJID_DIN_16_POL, 591
- IOOBJID_DIN_16_VALUE, 591
- IOOBJID_DIN_1_FILTER, 591
- IOOBJID_DIN_1_MASK_ANY, 591
- IOOBJID_DIN_1_MASK_H2L, 591
- IOOBJID_DIN_1_MASK_L2H, 591
- IOOBJID_DIN_1_POL, 591
- IOOBJID_DIN_1_VALUE, 590
- IOOBJID_DIN_32_FILTER, 591
- IOOBJID_DIN_32_MASK_ANY, 591
- IOOBJID_DIN_32_MASK_H2L, 591
- IOOBJID_DIN_32_MASK_L2H, 591
- IOOBJID_DIN_32_POL, 591
- IOOBJID_DIN_32_VALUE, 591
- IOOBJID_DIN_8_FILTER, 590
- IOOBJID_DIN_8_MASK_ANY, 590
- IOOBJID_DIN_8_MASK_H2L, 590
- IOOBJID_DIN_8_MASK_L2H, 590
- IOOBJID_DIN_8_POL, 590
- IOOBJID_DIN_8_VALUE, 590
- IOOBJID_DIN_INTENA, 590
- IOOBJID_DOUT_16_ERRMODE, 591
- IOOBJID_DOUT_16_ERRVAL, 591
- IOOBJID_DOUT_16_FILTER, 591
- IOOBJID_DOUT_16_POL, 591
- IOOBJID_DOUT_16_VALUE, 591
- IOOBJID_DOUT_1_ERRMODE, 591
- IOOBJID_DOUT_1_ERRVAL, 591
- IOOBJID_DOUT_1_FILTER, 591
- IOOBJID_DOUT_1_POL, 591
- IOOBJID_DOUT_1_VALUE, 591
- IOOBJID_DOUT_32_ERRMODE, 591
- IOOBJID_DOUT_32_ERRVAL, 591
- IOOBJID_DOUT_32_FILTER, 591
- IOOBJID_DOUT_32_POL, 591
- IOOBJID_DOUT_32_VALUE, 591
- IOOBJID_DOUT_8_ERRMODE, 591
- IOOBJID_DOUT_8_ERRVAL, 591
- IOOBJID_DOUT_8_FILTER, 591
- IOOBJID_DOUT_8_POL, 591
- IOOBJID_DOUT_8_VALUE, 591
- CML_Linkage.h
 - LINKEVENT_ABORT, 595
 - LINKEVENT_DISABLED, 594
 - LINKEVENT_ERROR, 594
 - LINKEVENT_FAULT, 594
 - LINKEVENT_MOVEDONE, 594
 - LINKEVENT_NEGLIM, 594
 - LINKEVENT_NODEGUARD, 594
 - LINKEVENT_POSLIM, 594
 - LINKEVENT_POSWARN, 594
 - LINKEVENT_POSWIN, 594
 - LINKEVENT_QUICKSTOP, 595
 - LINKEVENT_SOFTLIM_NEG, 595
 - LINKEVENT_SOFTLIM_POS, 595
 - LINKEVENT_TRJDONE, 594
 - LINKEVENT_VELWIN, 594
- CML_Network.h
 - GUARDTYPE_HEARTBEAT, 597
 - GUARDTYPE_NODEGUARD, 597
 - GUARDTYPE_NONE, 597
 - NET_TYPE_CANOPEN, 598
 - NET_TYPE_ETHERCAT, 598
 - NET_TYPE_INVALID, 598
 - NODESTATE_GUARDERR, 598
 - NODESTATE_INVALID, 598
 - NODESTATE_OPERATIONAL, 598
 - NODESTATE_PRE_OP, 598
 - NODESTATE_SAFE_OP, 598
 - NODESTATE_STOPPED, 598
 - NODESTATE_UNKNOWN, 598
- CAN_BIT_RATE
 - CML_AmpStruct.h, 566
- CAN_FRAME_TYPE
 - CML_Can.h, 569
- CIO_OBJID
 - CML_CopleyIO.h, 575
- CME_Config
 - AmpConfig, 144
- CML.cpp, 536
- CML.h, 537
 - CML_LOG_LEVEL, 538
- CML_Amp.h, 538
- CML_AmpDef.h, 540
 - AMP_EVENT, 548
 - AMP_FAULT, 549
 - AMP_FEATURE, 550
 - AMP_MODE, 551
 - AMP_PWM_MODE, 553

- AMP_TRACE_VAR, 554
- EVENT_STATUS, 558
- HALT_MODE, 559
- PROFILE_TYPE, 562
- CML_AmpStruct.h, 563
 - CAN_BIT_RATE, 566
- CML_Array.h, 566
- CML_Can.h, 567
 - CAN_FRAME_TYPE, 569
- CML_CanOpen.h, 569
- CML_Copley.h, 571
- CML_CopleyIO.h, 572
 - CIO_OBJID, 575
- CML_DEBUG_ASSERT
 - CML_Settings.h, 607
- CML_Error.h, 576
- CML_EtherCAT.h, 577
- CML_EventMap.h, 579
- CML_File.h, 581
- CML_Filter.h, 582
- CML_Firmware.h, 583
- CML_Geometry.h, 585
- CML_HASH_SIZE
 - CML_Settings.h, 608
- CML_IO.h, 587
 - IO_OBJID, 590
- CML_InputShaper.h, 586
- CML_LOG_LEVEL
 - CML.h, 538
- CML_Linkage.h, 593
 - LINK_EVENT, 594
- CML_NAMESPACE
 - CML_Settings.h, 609
- CML_Network.h, 595
 - GuardProtocol, 597
 - NetworkType, 597
 - NodeState, 598
- CML_Node.h, 598
- CML_PDO.h, 599
- CML_Reference.h, 601
- CML_SDO.h, 603
- CML_Settings.h, 605
 - CML_HASH_SIZE, 608
 - CML_NAMESPACE, 609
- CML_Threads.h, 609
- CML_Trajectory.h, 611
- CML_TrjScurve.h, 612
- CML_Utils.h, 613
 - ByteCast, 615
 - int16, 615
 - int32, 615
 - int64, 615
 - uint16, 615
 - uint32, 615
 - uunit, 615
- Calculate
 - LinkTrjScurve, 390
 - TrjScurve, 516
- calibration
 - AnalogRefConfig, 162
- CammingConfig, 170
 - CammingConfig, 170
 - cammingMasterVel, 170
 - CammingConfig, 170
- cammingMasterVel
 - CammingConfig, 170
- Can.cpp, 530
- can_copley.h, 530
- can_ixxat.h, 532
- can_ixxat_v3.h, 533
- can_kvaser.h, 534
- CanError, 171
- CanFrame, 172
 - data, 173
 - id, 173
 - length, 173
- CanInterface, 174
 - CanInterface, 175
 - CanInterface, 175
 - ChkID, 176
 - Close, 176
 - Open, 176
 - portName, 178
 - Recv, 176
 - RecvFrame, 177
 - SetBaud, 177
 - SetName, 177
 - SupportsTimestamps, 177
 - Xmit, 178
 - XmitFrame, 178
- CanNetworkConfig, 179
 - FromAmpFormat, 180
 - heartbeat, 180
 - nodeGuard, 181
 - nodeGuardLife, 181
 - numInPins, 181
 - offset, 181
 - pinMapping, 181
 - ToAmpFormat, 180
 - useSwitch, 181
- CanOpen, 181
 - ~CanOpen, 184
 - AttachNode, 184
 - BootModeNode, 184
 - CanOpen, 184
 - CanOpen, 184
 - Close, 185
 - DetachNode, 185

- DisableReceiver, 185
- EnableReceiver, 185
- GetErrorFrameCounter, 186
- GetNetworkType, 186
- GetSynchProducer, 186
- Open, 186
- PreOpNode, 187
- ResetComm, 187
- ResetNode, 187
- SetNodeGuard, 188
- SetSynchProducer, 188
- StartNode, 188
- StopNode, 188
- Xmit, 189
- XmitPDO, 189
- XmitSDO, 189
- CanOpen.cpp, 536
- CanOpenError, 190
 - IllegalFieldCt, 192
 - Initialized, 192
 - MonitorRunning, 192
 - NotInitialized, 192
 - SDO_BadMuxRcvd, 192
- CanOpenNodeInfo, 193
 - guardTimeout, 194
 - guardToggle, 194
 - guardType, 194
- CanOpenSettings, 195
 - CanOpenSettings, 195
 - CanOpenSettings, 195
 - readThreadPriority, 195
 - syncID, 195
 - timeID, 196
 - useAsTimingReference, 196
- capCtrl
 - AmpConfig, 144
- cfg
 - PwmInConfig, 467
- changeBits
 - EventMap, 266
- channel
 - IxxatCAN, 362
 - IxxatCANV3, 365
- checkNdx
 - EcatDgram, 233
- CheckStateForMove
 - Amp, 47
- ChkID
 - CanInterface, 176
- ClearErrorHistory
 - Node, 412
- ClearEventLatch
 - Amp, 47
- ClearFaults
 - Amp, 47
- ClearLatchedError
 - Linkage, 373
- ClearMap
 - PDO, 436
- ClearNodeGuardEvent
 - Amp, 48
- Close
 - CanInterface, 176
 - CanOpen, 185
 - CopleyCAN, 198
 - IxxatCAN, 359
 - IxxatCANV3, 364
 - KvaserCAN, 368
- clrBits
 - EventMap, 267
- Configure
 - Linkage, 373
- contLim
 - CrntLoopConfig, 222
- contPower
 - RegenConfig, 476
- ConvertAmpToAxis
 - Linkage, 373
- ConvertAmpToAxisPos
 - Linkage, 374
- ConvertAxisToAmp
 - Linkage, 374
- ConvertAxisToAmpPos
 - Linkage, 374
- ConvertError
 - IxxatCAN, 359
 - IxxatCANV3, 364
 - KvaserCAN, 368
- CopleyCAN, 196
 - Close, 198
 - local, 199
 - Open, 198
 - RecvFrame, 198
 - SetBaud, 198
 - SupportsTimestamps, 199
 - XmitFrame, 199
- CopleyIO, 200
 - CopleyIO, 202
 - CopleyIO, 202
 - GetIOAnlg, 203
 - GetIOCfg, 203
 - GetIODigi, 203
 - GetIOInfo, 203
 - GetIOPWM, 204
 - Init, 204
 - LoadFromFile, 204
 - SaveIOConfig, 205
 - SerialCmd, 205

- SetIOAnlg, [206](#)
- SetIOConfig, [206](#)
- SetIODigi, [206](#)
- SetIOInfo, [206](#)
- SetIOPWM, [208](#)
- CopleyIO.cpp, [616](#)
- CopleyIOAnlg, [208](#)
- CopleyIOCfg, [209](#)
- CopleyIODigi, [210](#)
- CopleyIOInfo, [211](#)
- CopleyIOPWM, [212](#)
- CopleyMotionLibrary, [213](#)
 - ~CopleyMotionLibrary, [214](#)
 - Debug, [214](#)
 - Error, [214](#)
 - FlushLog, [214](#)
 - GetDebugLevel, [214](#)
 - GetFlushLog, [214](#)
 - GetLogFile, [215](#)
 - GetMaxLogSize, [215](#)
 - GetVersionString, [215](#)
 - LogCAN, [215](#)
 - SetDebugLevel, [215](#)
 - SetFlushLog, [216](#)
 - SetLogFile, [216](#)
 - SetMaxLogSize, [216](#)
 - Warn, [216](#)
- CopleyNode, [217](#)
 - FirmwareUpdate, [218](#)
 - SerialCmd, [219](#)
- CopleyNode.cpp, [616](#)
- CopleyNodeError, [219](#)
- CrntLoopConfig, [221](#)
 - contLim, [222](#)
 - CrntLoopConfig, [222](#)
 - CrntLoopConfig, [222](#)
 - peakTime, [222](#)
 - slope, [222](#)
 - stepHoldCurrent, [222](#)
 - stepRun2HoldTime, [223](#)
 - stepVolControlDelayTime, [223](#)
- current
 - HomeConfig, [279](#)
- cyclePeriod
 - EtherCatSettings, [253](#)
- cycleThreadPriority
 - EtherCatSettings, [253](#)
- DAConfig, [223](#)
 - daConverterConfig, [223](#)
- daConverterConfig
 - DAConfig, [223](#)
- data
 - CanFrame, [173](#)
- deadband
 - AnalogRefConfig, [162](#)
- Debug
 - CopleyMotionLibrary, [214](#)
- dec
 - ProfileConfigTrap, [463](#)
 - ProfileConfigVel, [464](#)
- DecodeFault
 - AmpFault, [152](#)
- DecodeStatus
 - AmpError, [149](#)
- delChain
 - Event, [256](#)
- delay
 - HomeConfig, [280](#)
- DetachNode
 - CanOpen, [185](#)
- Din16GetCt
 - IOModule, [322](#)
- Din16GetFilt
 - IOModule, [322](#)
- Din16GetMaskAny
 - IOModule, [322](#)
- Din16GetMaskHigh2Low
 - IOModule, [322](#)
- Din16GetMaskLow2High
 - IOModule, [323](#)
- Din16GetPol
 - IOModule, [323](#)
- Din16Read
 - IOModule, [323](#)
- Din16SetFilt
 - IOModule, [324](#)
- Din16SetMaskAny
 - IOModule, [324](#)
- Din16SetMaskHigh2Low
 - IOModule, [324](#)
- Din16SetMaskLow2High
 - IOModule, [325](#)
- Din16SetPol
 - IOModule, [325](#)
- Din32GetCt
 - IOModule, [325](#)
- Din32GetFilt
 - IOModule, [325](#)
- Din32GetMaskAny
 - IOModule, [326](#)
- Din32GetMaskHigh2Low
 - IOModule, [326](#)
- Din32GetMaskLow2High
 - IOModule, [326](#)
- Din32GetPol
 - IOModule, [327](#)
- Din32Read

IOModule, [327](#)
 Din32SetFilt
 IOModule, [327](#)
 Din32SetMaskAny
 IOModule, [327](#)
 Din32SetMaskHigh2Low
 IOModule, [329](#)
 Din32SetMaskLow2High
 IOModule, [329](#)
 Din32SetPol
 IOModule, [329](#)
 Din8GetCt
 IOModule, [329](#)
 Din8GetFilt
 IOModule, [331](#)
 Din8GetMaskAny
 IOModule, [331](#)
 Din8GetMaskHigh2Low
 IOModule, [331](#)
 Din8GetMaskLow2High
 IOModule, [331](#)
 Din8GetPol
 IOModule, [332](#)
 Din8Read
 IOModule, [332](#)
 Din8SetFilt
 IOModule, [332](#)
 Din8SetMaskAny
 IOModule, [333](#)
 Din8SetMaskHigh2Low
 IOModule, [333](#)
 Din8SetMaskLow2High
 IOModule, [333](#)
 Din8SetPol
 IOModule, [333](#)
 DinGetCt
 IOModule, [334](#)
 DinGetFilt
 IOModule, [334](#)
 DinGetIntEna
 IOModule, [334](#)
 DinGetMaskAny
 IOModule, [335](#)
 DinGetMaskHigh2Low
 IOModule, [335](#)
 DinGetMaskLow2High
 IOModule, [335](#)
 DinGetPol
 IOModule, [335](#)
 DinRead
 IOModule, [337](#)
 DinSetFilt
 IOModule, [337](#)
 DinSetIntEna
 IOModule, [337](#)
 DinSetMaskAny
 IOModule, [337](#)
 DinSetMaskHigh2Low
 IOModule, [338](#)
 DinSetMaskLow2High
 IOModule, [338](#)
 DinSetPol
 IOModule, [338](#)
 dir
 ProfileConfigVel, [464](#)
 Disable
 Amp, [48](#)
 DisableBlkDnld
 SDO, [486](#)
 DisableBlkUpd
 SDO, [486](#)
 DisableReceiver
 CanOpen, [185](#)
 Dnld16
 Amp, [48](#), [49](#)
 SDO, [486](#), [488](#)
 Dnld32
 Amp, [49](#)
 SDO, [488](#)
 Dnld8
 Amp, [49](#), [50](#)
 SDO, [488](#), [490](#)
 DnldFit
 SDO, [490](#)
 DnldString
 Amp, [50](#)
 SDO, [490](#)
 DoMove
 Amp, [50](#), [51](#)
 Dout16GetCt
 IOModule, [339](#)
 Dout16GetErrMode
 IOModule, [339](#)
 Dout16GetErrValue
 IOModule, [339](#)
 Dout16GetFilt
 IOModule, [339](#)
 Dout16GetPol
 IOModule, [340](#)
 Dout16Read
 IOModule, [340](#)
 Dout16SetErrMode
 IOModule, [340](#)
 Dout16SetErrValue
 IOModule, [341](#)
 Dout16SetFilt
 IOModule, [341](#)
 Dout16SetPol

- IOModule, [341](#)
- Dout16Write
 - IOModule, [341](#)
- Dout32GetCt
 - IOModule, [342](#)
- Dout32GetErrMode
 - IOModule, [342](#)
- Dout32GetErrValue
 - IOModule, [342](#)
- Dout32GetFilt
 - IOModule, [343](#)
- Dout32GetPol
 - IOModule, [343](#)
- Dout32Read
 - IOModule, [343](#)
- Dout32SetErrMode
 - IOModule, [343](#)
- Dout32SetErrValue
 - IOModule, [344](#)
- Dout32SetFilt
 - IOModule, [344](#)
- Dout32SetPol
 - IOModule, [344](#)
- Dout32Write
 - IOModule, [345](#)
- Dout8GetCt
 - IOModule, [345](#)
- Dout8GetErrMode
 - IOModule, [345](#)
- Dout8GetErrValue
 - IOModule, [346](#)
- Dout8GetFilt
 - IOModule, [346](#)
- Dout8GetPol
 - IOModule, [346](#)
- Dout8Read
 - IOModule, [346](#)
- Dout8SetErrMode
 - IOModule, [348](#)
- Dout8SetErrValue
 - IOModule, [348](#)
- Dout8SetFilt
 - IOModule, [348](#)
- Dout8SetPol
 - IOModule, [349](#)
- Dout8Write
 - IOModule, [349](#)
- DoutGetCt
 - IOModule, [349](#)
- DoutGetErrMode
 - IOModule, [349](#)
- DoutGetErrValue
 - IOModule, [350](#)
- DoutGetFilt
 - IOModule, [350](#)
- DoutGetPol
 - IOModule, [350](#)
- DoutSetErrMode
 - IOModule, [351](#)
- DoutSetErrValue
 - IOModule, [351](#)
- DoutSetFilt
 - IOModule, [351](#)
- DoutSetPol
 - IOModule, [352](#)
- DoutWrite
 - IOModule, [352](#)
- Download
 - Amp, [52](#)
 - SDO, [491](#)
- ESTAT_ACC_LIMIT
 - CML_AmpDef.h, [558](#)
- ESTAT_AMP_TEMP
 - CML_AmpDef.h, [558](#)
- ESTAT_BRAKE
 - CML_AmpDef.h, [558](#)
- ESTAT_CMD_INPUT
 - CML_AmpDef.h, [559](#)
- ESTAT_CRNT_LIM
 - CML_AmpDef.h, [558](#)
- ESTAT_DISABLE_INPUT
 - CML_AmpDef.h, [558](#)
- ESTAT_ENCODER_PWR
 - CML_AmpDef.h, [558](#)
- ESTAT_FAULT
 - CML_AmpDef.h, [558](#)
- ESTAT_HOME
 - CML_AmpDef.h, [558](#)
- ESTAT_MOVING
 - CML_AmpDef.h, [559](#)
- ESTAT_MTR_TEMP
 - CML_AmpDef.h, [558](#)
- ESTAT_NEGLIM
 - CML_AmpDef.h, [558](#)
- ESTAT_OVER_VOLT
 - CML_AmpDef.h, [558](#)
- ESTAT_PHASE_ERR
 - CML_AmpDef.h, [558](#)
- ESTAT_PHASE_INIT
 - CML_AmpDef.h, [559](#)
- ESTAT_POSLIM
 - CML_AmpDef.h, [558](#)
- ESTAT_POSWRAP
 - CML_AmpDef.h, [558](#)
- ESTAT_PWM_DISABLE
 - CML_AmpDef.h, [558](#)
- ESTAT_RESET

- CML_AmpDef.h, 558
- ESTAT_SHORT_CRCT
 - CML_AmpDef.h, 558
- ESTAT_SOFT_DISABLE
 - CML_AmpDef.h, 558
- ESTAT_SOFTLIM_NEG
 - CML_AmpDef.h, 558
- ESTAT_SOFTLIM_POS
 - CML_AmpDef.h, 558
- ESTAT_STOP
 - CML_AmpDef.h, 558
- ESTAT_TRK_ERR
 - CML_AmpDef.h, 558
- ESTAT_TRK_WARN
 - CML_AmpDef.h, 558
- ESTAT_TRK_WIN
 - CML_AmpDef.h, 558
- ESTAT_UNDER_VOLT
 - CML_AmpDef.h, 558
- ESTAT_VEL_LIMIT
 - CML_AmpDef.h, 558
- ESTAT_VEL_WIN
 - CML_AmpDef.h, 559
- ESTAT_VOLT_LIM
 - CML_AmpDef.h, 558
- EVENT_STATUS
 - CML_AmpDef.h, 558
- EcatDgram, 232
 - checkNdx, 233
 - EcatDgram, 233
 - EcatDgram, 233
 - getDgramLen, 233
 - getNdx, 234
 - getNext, 234
 - Init, 234
 - Load, 235
 - setData, 235
 - setNdx, 235
 - setNext, 235
- EcatFrame, 236
- ecatdc.cpp, 617
- Enable
 - Amp, 52
- EnableBikDnld
 - SDO, 491
- EnableBikUpd
 - SDO, 491
- enableOnInit
 - AmpSettings, 159
- EnableReceiver
 - CanOpen, 185
- encoderOutCfg
 - AmpConfig, 145
- Error, 237
 - CopleyMotionLibrary, 214
 - Error, 240
 - GetID, 240
 - Lookup, 240
 - toString, 241
- Error.cpp, 617
- estopDec
 - VelLoopConfig, 520
- EtherCAT, 241
 - AddToFrame, 243
 - FoE_DnldData, 243
 - FoE_DnldStart, 244
 - FoE_LastErrInfo, 244
 - FoE_UpdData, 244
 - FoE_UpdStart, 245
 - GetIdFromEEPROM, 245
 - GetNetworkType, 245
 - GetNodeAddress, 245
 - getNodeCount, 246
 - InitDistClk, 246
 - MailboxTransfer, 246
 - maxSdoFromNode, 246
 - maxSdoToNode, 248
 - SetNodeGuard, 248
 - SetSync0Period, 248
 - WaitCycleUpdate, 249
- EtherCAT.cpp, 618
 - SM_RXMBX, 618
- EtherCatError, 249
- EtherCatHardware, 252
- EtherCatSettings, 253
 - cyclePeriod, 253
 - cycleThreadPriority, 253
 - EtherCatSettings, 253
 - EtherCatSettings, 253
 - readThreadPriority, 253
- Event, 254
 - ~Event, 255
 - delChain, 256
 - Event, 255
 - getMask, 256
 - getValue, 256
 - isTrue, 256
 - operator=, 256
 - setChain, 257
 - setValue, 257
 - Wait, 257
- EventAll, 258
 - EventAll, 259
 - EventAll, 259
 - isTrue, 259
- EventAny, 260
 - EventAny, 261
 - EventAny, 261

- isTrue, [261](#)
- EventAnyClear, [261](#)
 - EventAnyClear, [263](#), [264](#)
 - EventAnyClear, [263](#), [264](#)
 - isTrue, [264](#)
- EventError, [264](#)
- EventMap, [265](#)
 - ~EventMap, [266](#)
 - Add, [266](#)
 - changeBits, [266](#)
 - clrBits, [267](#)
 - getMask, [267](#)
 - Remove, [267](#)
 - setBits, [267](#)
 - setMask, [267](#)
- EventMap.cpp, [618](#)
- EventNone, [269](#)
 - EventNone, [270](#)
 - EventNone, [270](#)
 - isTrue, [270](#)
- extended
 - HomeConfig, [280](#)
- FAULT_ADCOFFSET
 - CML_AmpDef.h, [549](#)
- FAULT_AMP_TEMP
 - CML_AmpDef.h, [549](#)
- FAULT_DATAFLASH
 - CML_AmpDef.h, [549](#)
- FAULT_ENCODER_PWR
 - CML_AmpDef.h, [550](#)
- FAULT_I2T_ERR
 - CML_AmpDef.h, [550](#)
- FAULT_MTR_TEMP
 - CML_AmpDef.h, [549](#)
- FAULT_OVER_VOLT
 - CML_AmpDef.h, [550](#)
- FAULT_PHASE_ERR
 - CML_AmpDef.h, [550](#)
- FAULT_SHORT_CRCT
 - CML_AmpDef.h, [549](#)
- FAULT_TRK_ERR
 - CML_AmpDef.h, [550](#)
- FAULT_UNDER_VOLT
 - CML_AmpDef.h, [550](#)
- FEATURE_AIN_FILTER
 - CML_AmpDef.h, [550](#)
- FEATURE_ALGO_PHASE_INIT_CONFIG
 - CML_AmpDef.h, [550](#)
- FEATURE_ALGO_PHASE_INIT_CUR
 - CML_AmpDef.h, [550](#)
- FEATURE_AXIS_CT
 - CML_AmpDef.h, [551](#)
- FEATURE_BRAKE_ENABLE_DELAY
 - CML_AmpDef.h, [551](#)
- FEATURE_CAMMING
 - CML_AmpDef.h, [550](#)
- FEATURE_CAN_OPTIONS
 - CML_AmpDef.h, [550](#)
- FEATURE_CAN_SETTINGS
 - CML_AmpDef.h, [550](#)
- FEATURE_CURRENT_SLOPE
 - CML_AmpDef.h, [550](#)
- FEATURE_DA_CONV_CONFIG
 - CML_AmpDef.h, [551](#)
- FEATURE_ENC_OPTIONS
 - CML_AmpDef.h, [550](#)
- FEATURE_EXTENDED_OUTPUT_PIN_CONFIG
 - CML_AmpDef.h, [550](#)
- FEATURE_FLOAT_FILTER_COEF
 - CML_AmpDef.h, [551](#)
- FEATURE_GAIN_SCHED
 - CML_AmpDef.h, [550](#)
- FEATURE_GEAR_RATIO
 - CML_AmpDef.h, [550](#)
- FEATURE_HALL_VEL_SHIFT
 - CML_AmpDef.h, [550](#)
- FEATURE_ILOOP_CMD_FILTER
 - CML_AmpDef.h, [550](#)
- FEATURE_INPUT_SHAPING
 - CML_AmpDef.h, [551](#)
- FEATURE_IO_OPTIONS
 - CML_AmpDef.h, [551](#)
- FEATURE_MTR_OVERTEMP
 - CML_AmpDef.h, [551](#)
- FEATURE_NET_OPTIONS
 - CML_AmpDef.h, [551](#)
- FEATURE_PIN_MAP
 - CML_AmpDef.h, [550](#)
- FEATURE_PLOOP_KD
 - CML_AmpDef.h, [551](#)
- FEATURE_PLOOP_KI
 - CML_AmpDef.h, [551](#)
- FEATURE_PLOOP_SCALE
 - CML_AmpDef.h, [550](#)
- FEATURE_POS_WRAP
 - CML_AmpDef.h, [550](#)
- FEATURE_PWMIN_FREQ
 - CML_AmpDef.h, [550](#)
- FEATURE_PWMIN_MAX_PULSE
 - CML_AmpDef.h, [550](#)
- FEATURE_PWMIN_MIN_PULSE
 - CML_AmpDef.h, [550](#)
- FEATURE_PWMIN_UVCFG
 - CML_AmpDef.h, [551](#)
- FEATURE_RESOLVER_CYCLES
 - CML_AmpDef.h, [550](#)
- FEATURE_SERVO_CONFIG

- CML_AmpDef.h, [551](#)
- FEATURE_SOFTLIM_ACCEL
 - CML_AmpDef.h, [550](#)
- FEATURE_STEP_DETENT_GAIN
 - CML_AmpDef.h, [550](#)
- FEATURE_STEPPER_CRNT
 - CML_AmpDef.h, [550](#)
- FEATURE_USTEP_CONFIG_STATUS
 - CML_AmpDef.h, [550](#)
- FEATURE_USTEP_OUTER_LOOP
 - CML_AmpDef.h, [550](#)
- FEATURE_VLOOP_CMD_FILT
 - CML_AmpDef.h, [550](#)
- FEATURE_VLOOP_CMDFF
 - CML_AmpDef.h, [551](#)
- FEATURE_VLOOP_OUT_FILT
 - CML_AmpDef.h, [550](#)
- FPRD, [275](#)
- FPWR, [276](#)
- File.cpp, [619](#)
- Filter, [271](#)
 - Filter, [271](#)
 - LoadFromCCX, [271](#)
- Filter.cpp, [619](#)
- FindAmpSerial
 - LSS, [395](#)
- FindAmplifiers
 - LSS, [394](#)
- Finish
 - LinkTrajectory, [387](#)
 - Trajectory, [511](#)
- Firmware, [272](#)
 - getAmpType, [272](#)
 - getData, [272](#)
 - getFileVersion, [272](#)
 - getLength, [273](#)
 - getStart, [273](#)
 - progress, [273](#)
- Firmware.cpp, [621](#)
- FirmwareError, [273](#)
- FirmwareUpdate
 - CopleyNode, [218](#)
- FlushLog
 - CopleyMotionLibrary, [214](#)
- FoE_DnldData
 - EtherCAT, [243](#)
- FoE_DnldStart
 - EtherCAT, [244](#)
- FoE_LastErrInfo
 - EtherCAT, [244](#)
- FoE_UpldData
 - EtherCAT, [244](#)
- FoE_UpldStart
 - EtherCAT, [245](#)
- FormatPosInit
 - Amp, [52](#)
- FormatPtSeg
 - Amp, [52](#)
- FormatPvtSeg
 - Amp, [53](#)
- freq
 - PwmInConfig, [467](#)
- FromAmpFormat
 - CanNetworkConfig, [180](#)
- FuncGenConfig, [277](#)
 - amp, [278](#)
- GUARDTYPE_HEARTBEAT
 - CML_Network.h, [597](#)
- GUARDTYPE_NODEGUARD
 - CML_Network.h, [597](#)
- GUARDTYPE_NONE
 - CML_Network.h, [597](#)
- GainScheduling, [278](#)
 - GainScheduling, [278](#)
 - GainScheduling, [278](#)
- gearRatio
 - MtrInfo, [400](#)
- Geometry.cpp, [622](#)
- Get
 - Pmap, [440](#)
 - Pmap16, [443](#)
 - Pmap24, [446](#)
 - Pmap32, [449](#)
 - Pmap8, [452](#)
 - PmapRaw, [455](#)
 - Semaphore, [499](#)
- GetAdapterDesc
 - PcapEcatHardware, [433](#)
- GetAdapterName
 - PcapEcatHardware, [433](#)
- GetAlgoPhaseInit
 - Amp, [53](#)
- GetAmp
 - Linkage, [376](#)
- GetAmpConfig
 - Amp, [53](#)
- GetAmpCount
 - Linkage, [376](#)
- GetAmpInfo
 - Amp, [54](#)
- GetAmpMode
 - Amp, [54](#)
- GetAmpName
 - Amp, [54](#)
- GetAmpNodeID
 - LSS, [395](#)
- GetAmpRef

- Linkage, [376](#)
- GetAmpTemp
 - Amp, [54](#)
- getAmpType
 - Firmware, [272](#)
- GetAnalogCommandFilter
 - Amp, [55](#)
- GetAnalogEncoder
 - Amp, [55](#)
- GetAnalogRefConfig
 - Amp, [55](#)
- GetAxesCount
 - Linkage, [376](#)
- GetBitVal
 - IOModule::DigInPDO, [225](#)
- GetBits
 - Pmap, [441](#)
- GetCammingConfig
 - Amp, [55](#)
- GetCanNetworkConfig
 - Amp, [56](#)
- GetControlWord
 - Amp, [56](#)
- GetCountsPerUnit
 - Amp, [56](#)
- GetCrntLoopConfig
 - Amp, [57](#)
- GetCurrentActual
 - Amp, [57](#)
- GetCurrentCommand
 - Amp, [57](#)
- GetCurrentLimited
 - Amp, [59](#)
- GetCurrentProgrammed
 - Amp, [59](#)
- GetDAConverterConfig
 - Amp, [59](#)
- getData
 - Firmware, [272](#)
- GetDebugLevel
 - CopleyMotionLibrary, [214](#)
- GetDeviceType
 - Node, [412](#)
- getDgramLen
 - EcatDgram, [233](#)
- GetDim
 - LinkTrajectory, [387](#)
 - LinkTrjScurve, [390](#)
 - Path, [426](#)
- getDim
 - Point, [457](#)
 - PointN, [458](#)
- GetErrorFrameCounter
 - CanOpen, [186](#)
- GetErrorHistory
 - Node, [412](#)
- GetErrorRegister
 - Node, [412](#)
- GetErrorStatus
 - Amp, [59](#)
- GetEventLatch
 - Amp, [61](#)
- GetEventMask
 - Amp, [61](#)
- GetEventStatus
 - Amp, [61](#)
- GetEventSticky
 - Amp, [62](#)
- GetFaultMask
 - Amp, [62](#)
- GetFaults
 - Amp, [62](#)
- getFileVersion
 - Firmware, [272](#)
- GetFlushLog
 - CopleyMotionLibrary, [214](#)
- GetFuncGenConfig
 - Amp, [62](#)
- GetGainScheduling
 - Amp, [63](#)
- GetHallState
 - Amp, [63](#)
- GetHaltMode
 - Amp, [63](#)
- GetHighVoltage
 - Amp, [63](#)
- GetHomeAccel
 - Amp, [64](#)
- GetHomeAdjustment
 - Amp, [64](#)
- GetHomeCapture
 - Amp, [64](#)
- GetHomeConfig
 - Amp, [64](#)
- GetHomeCurrent
 - Amp, [65](#)
- GetHomeDelay
 - Amp, [65](#)
- GetHomeMethod
 - Amp, [65](#)
- GetHomeOffset
 - Amp, [65](#)
- GetHomeVelFast
 - Amp, [66](#)
- GetHomeVelSlow
 - Amp, [66](#)
- GetID
 - Error, [240](#)

- PDO, [436](#)
- GetIOAnlg
 - CopleyIO, [203](#)
- GetIOCfg
 - CopleyIO, [203](#)
- GetIODigi
 - CopleyIO, [203](#)
- GetIOInfo
 - CopleyIO, [203](#)
- GetIOOptions
 - Amp, [69](#)
- GetIOPWM
 - CopleyIO, [204](#)
- GetIdFromEEPROM
 - EtherCAT, [245](#)
- GetIdentity
 - Node, [413](#)
- GetloopCommandFilter
 - Amp, [66](#)
- GetloopCommandFilter2
 - Amp, [66](#)
- GetInVal
 - IOModule::AlInPDO, [24](#)
 - IOModule::DigInPDO, [227](#)
- GetIndex
 - Pmap, [441](#)
- GetIndexCapture
 - Amp, [67](#)
- GetInputConfig
 - Amp, [67](#)
- GetInputDebounce
 - Amp, [68](#)
- GetInputShapingFilter
 - Amp, [69](#)
- GetInputs
 - Amp, [68](#)
- GetInputs32
 - Amp, [68](#)
- GetIoConfig
 - Amp, [69](#)
- GetIoPullup
 - Amp, [69](#)
- GetIoPullup32
 - Amp, [71](#)
- GetLatchedError
 - Linkage, [377](#)
- getLength
 - Firmware, [273](#)
- GetLinkRef
 - Amp, [71](#)
- GetLinkage
 - Amp, [71](#)
- GetLogFile
 - CopleyMotionLibrary, [215](#)
- GetMapCodes
 - PDO, [436](#)
- getMask
 - Event, [256](#)
 - EventMap, [267](#)
- getMax
 - Point, [457](#)
 - PointN, [458](#)
- GetMaxLogSize
 - CopleyMotionLibrary, [215](#)
- GetMaxRetry
 - SDO, [492](#)
- GetMfgDeviceName
 - Node, [413](#)
- GetMfgHardwareVer
 - Node, [413](#)
- GetMfgSoftwareVer
 - Node, [413](#)
- GetMfgStatus
 - Node, [414](#)
- GetMicrostepRate
 - Amp, [71](#)
- GetMotorCurrent
 - Amp, [72](#)
- GetMoveLimits
 - Linkage, [377](#)
- GetMtrInfo
 - Amp, [72](#)
- getNdx
 - EcatDgram, [234](#)
- GetNetworkOptions
 - Amp, [72](#)
- GetNetworkRef
 - Amp, [72](#)
 - Node, [414](#)
- GetNetworkType
 - CanOpen, [186](#)
 - EtherCAT, [245](#)
 - Node, [414](#)
- getNext
 - EcatDgram, [234](#)
- GetNodeAddress
 - EtherCAT, [245](#)
- getNodeCount
 - EtherCAT, [246](#)
- GetNodeID
 - Node, [414](#)
- GetNodeInfo
 - Network, [404](#)
- GetOutputConfig
 - Amp, [72, 74, 75](#)
- GetOutputs
 - Amp, [75](#)
- GetPhaseAngle

Amp, 75
GetPhaseMode
 Amp, 76
GetPosCaptureCfg
 Amp, 76
GetPosCaptureStat
 Amp, 76
GetPosLoopConfig
 Amp, 79
GetPosition
 PvtSegCache, 466
GetPositionActual
 Amp, 76
GetPositionCommand
 Amp, 78
 Linkage, 377
GetPositionError
 Amp, 78
GetPositionErrorWindow
 Amp, 78
GetPositionLoad
 Amp, 78
GetPositionMotor
 Amp, 79
GetPositionWarnWindow
 Amp, 79
GetProfileAcc
 Amp, 80
GetProfileConfig
 Amp, 80
GetProfileDec
 Amp, 80
GetProfileJerk
 Amp, 80
GetProfileType
 Amp, 81
GetProfileVel
 Amp, 81
GetPvtBuffFree
 Amp, 81
GetPvtBuffStat
 Amp, 81
GetPvtSegID
 Amp, 82
GetPvtSegPos
 Amp, 82
GetPwmInConfig
 Amp, 82
GetPwmMode
 Amp, 82
GetQuickStop
 Amp, 83
GetQuickStopDec
 Amp, 83
GetRefVoltage
 Amp, 83
GetRegenConfig
 Amp, 83
GetRtrOk
 PDO, 436
GetSegment
 PvtSegCache, 466
GetSettlingTime
 Amp, 84
GetSettlingWindow
 Amp, 84
GetSoftLimits
 Amp, 84
getStart
 Firmware, 273
GetStartPos
 TrjScurve, 517
GetState
 Amp, 84
 Node, 414
GetStatusWord
 Amp, 85
GetSub
 Pmap, 441
GetSynchId
 Node, 415
GetSynchPeriod
 Node, 415
GetSynchProducer
 CanOpen, 186
GetTargetPos
 Amp, 85
GetTargetVel
 Amp, 85
getTimeMS
 Thread, 503
GetTimeout
 SDO, 492
getTimeout
 LSS, 395
GetTorqueActual
 Amp, 86
GetTorqueDemand
 Amp, 86
GetTorqueRated
 Amp, 86
GetTorqueSlope
 Amp, 86
GetTorqueTarget
 Amp, 87
GetTraceChannel
 Amp, 87
GetTraceData

- Amp, [87](#)
- GetTraceMaxChannel
 - Amp, [88](#)
- GetTracePeriod
 - Amp, [88](#)
- GetTraceRefPeriod
 - Amp, [88](#)
- GetTraceStatus
 - Amp, [88](#)
- GetTraceTrigger
 - Amp, [90](#)
- GetTrackingWindows
 - Amp, [90](#)
- GetTrajectoryAcc
 - Amp, [90](#)
- GetTrajectoryVel
 - Amp, [91](#)
- GetType
 - PDO, [437](#)
- GetUstepConfig
 - Amp, [91](#)
- getValue
 - Event, [256](#)
- GetVelLoopConfig
 - Amp, [91](#)
- GetVelocityActual
 - Amp, [91](#)
- GetVelocityCommand
 - Amp, [93](#)
- GetVelocityLimited
 - Amp, [93](#)
- GetVelocityLoad
 - Amp, [93](#)
- GetVelocityProgrammed
 - Amp, [94](#)
- GetVelocityWarnTime
 - Amp, [94](#)
- GetVelocityWarnWindow
 - Amp, [94](#)
- GetVersionString
 - CopleyMotionLibrary, [215](#)
- GetVloopCommandFilter
 - Amp, [94](#)
- GetVloopOutputFilter
 - Amp, [95](#)
- GetVloopOutputFilter2
 - Amp, [95](#)
- GetVloopOutputFilter3
 - Amp, [95](#)
- GoHome
 - Amp, [95](#)
- GrabRef
 - RefObj, [472](#)
- GuardProtocol
 - CML_Network.h, [597](#)
- guardTime
 - AmpSettings, [159](#)
 - IOModuleSettings, [355](#)
- guardTimeout
 - CanOpenNodeInfo, [194](#)
- guardToggle
 - CanOpenNodeInfo, [194](#)
- guardType
 - CanOpenNodeInfo, [194](#)
- HALT_ABRUPT
 - CML_AmpDef.h, [559](#)
- HALT_DECEL
 - CML_AmpDef.h, [559](#)
- HALT_DISABLE
 - CML_AmpDef.h, [559](#)
- HALT_QUICKSTOP
 - CML_AmpDef.h, [559](#)
- HALT_MODE
 - CML_AmpDef.h, [559](#)
- hallVelShift
 - MtrInfo, [400](#)
- HaltMove
 - Amp, [96](#)
 - Linkage, [377](#)
- haltOnPosWarn
 - LinkSettings, [384](#)
- haltOnVelWin
 - LinkSettings, [384](#)
- HandleEmergency
 - Node, [415](#)
- HandleStateChange
 - Amp, [96](#)
 - Node, [415](#)
- heartbeat
 - CanNetworkConfig, [180](#)
- heartbeatPeriod
 - AmpSettings, [159](#)
 - IOModuleSettings, [355](#)
- heartbeatTimeout
 - AmpSettings, [160](#)
 - IOModuleSettings, [355](#)
- HomeConfig, [279](#)
 - accel, [279](#)
 - current, [279](#)
 - delay, [280](#)
 - extended, [280](#)
 - HomeConfig, [279](#)
 - HomeConfig, [279](#)
 - offset, [280](#)
 - velFast, [280](#)
 - velSlow, [280](#)
- INCFG_ABORT_WINDOW_F

CML_AmpDef.h, [560](#)
INCFG_ABORT_WINDOW_R
CML_AmpDef.h, [560](#)
INCFG_CLR_FAULTS_EVENTS_F
CML_AmpDef.h, [560](#)
INCFG_CLR_FAULTS_EVENTS_R
CML_AmpDef.h, [560](#)
INCFG_CLR_FAULTS_H
CML_AmpDef.h, [559](#)
INCFG_CLR_FAULTS_L
CML_AmpDef.h, [559](#)
INCFG_COUNT_EDGES_F
CML_AmpDef.h, [560](#)
INCFG_COUNT_EDGES_R
CML_AmpDef.h, [560](#)
INCFG_DIS_SIM_ENC_H_BURST_F
CML_AmpDef.h, [560](#)
INCFG_DIS_SIM_ENC_L_BURST_R
CML_AmpDef.h, [560](#)
INCFG_DISABLE_H
CML_AmpDef.h, [560](#)
INCFG_DISABLE_L
CML_AmpDef.h, [560](#)
INCFG_ENCODER_FAULT_H
CML_AmpDef.h, [560](#)
INCFG_ENCODER_FAULT_L
CML_AmpDef.h, [560](#)
INCFG_HIGHSPEED_CAPTURE_F
CML_AmpDef.h, [560](#)
INCFG_HIGHSPEED_CAPTURE_R
CML_AmpDef.h, [560](#)
INCFG_HOME_H
CML_AmpDef.h, [560](#)
INCFG_HOME_L
CML_AmpDef.h, [560](#)
INCFG_HV_LOSS_DISABLE_H
CML_AmpDef.h, [560](#)
INCFG_HV_LOSS_DISABLE_L
CML_AmpDef.h, [560](#)
INCFG_MOTION_ABORT_H
CML_AmpDef.h, [560](#)
INCFG_MOTION_ABORT_L
CML_AmpDef.h, [560](#)
INCFG_MOTOR_TEMP_H
CML_AmpDef.h, [559](#)
INCFG_MOTOR_TEMP_L
CML_AmpDef.h, [559](#)
INCFG_NEGLIM_H
CML_AmpDef.h, [559](#)
INCFG_NEGLIM_L
CML_AmpDef.h, [559](#)
INCFG_NONE
CML_AmpDef.h, [559](#)
INCFG_POSLIM_H
CML_AmpDef.h, [559](#)
INCFG_POSLIM_L
CML_AmpDef.h, [559](#)
INCFG_PWM_SYNC_H
CML_AmpDef.h, [560](#)
INCFG_RESET_DISABLE_F
CML_AmpDef.h, [559](#)
INCFG_RESET_DISABLE_R
CML_AmpDef.h, [559](#)
INCFG_RESET_F
CML_AmpDef.h, [559](#)
INCFG_RESET_R
CML_AmpDef.h, [559](#)
INCFG_SCALE_ADC_H
CML_AmpDef.h, [560](#)
INCFG_SCALE_ADC_L
CML_AmpDef.h, [560](#)
INCFG_TRJ_UPDATE_F
CML_AmpDef.h, [560](#)
INCFG_TRJ_UPDATE_R
CML_AmpDef.h, [560](#)
IOAINTRIG_LOWER_LIM
CML_IO.h, [590](#)
IOAINTRIG_NDELTA
CML_IO.h, [590](#)
IOAINTRIG_PDELTA
CML_IO.h, [590](#)
IOAINTRIG_UDELTA
CML_IO.h, [590](#)
IOAINTRIG_UPPER_LIM
CML_IO.h, [590](#)
IOEVENT_AIN_PDO0
CML_IO.h, [592](#)
IOEVENT_AIN_PDO1
CML_IO.h, [593](#)
IOEVENT_AIN_PDO2
CML_IO.h, [593](#)
IOEVENT_DIN_PDO0
CML_IO.h, [592](#)
IOOBJID_AIN_16_VALUE
CML_IO.h, [591](#)
IOOBJID_AIN_32_LWLIM
CML_IO.h, [592](#)
IOOBJID_AIN_32_NDELTA
CML_IO.h, [592](#)
IOOBJID_AIN_32_OFFSET
CML_IO.h, [592](#)
IOOBJID_AIN_32_PDELTA
CML_IO.h, [592](#)
IOOBJID_AIN_32_SCALE
CML_IO.h, [592](#)
IOOBJID_AIN_32_UDELTA
CML_IO.h, [592](#)
IOOBJID_AIN_32_UPLIM

CML_IO.h, [592](#)
IOOBJID_AIN_32_VALUE
CML_IO.h, [591](#)
IOOBJID_AIN_8_VALUE
CML_IO.h, [591](#)
IOOBJID_AIN_FLT_LWLIM
CML_IO.h, [592](#)
IOOBJID_AIN_FLT_NDELTA
CML_IO.h, [592](#)
IOOBJID_AIN_FLT_OFFSET
CML_IO.h, [592](#)
IOOBJID_AIN_FLT_PDELTA
CML_IO.h, [592](#)
IOOBJID_AIN_FLT_SCALE
CML_IO.h, [592](#)
IOOBJID_AIN_FLT_UDELTA
CML_IO.h, [592](#)
IOOBJID_AIN_FLT_UPLIM
CML_IO.h, [592](#)
IOOBJID_AIN_FLT_VALUE
CML_IO.h, [591](#)
IOOBJID_AIN_INTENA
CML_IO.h, [592](#)
IOOBJID_AIN_INTSRC
CML_IO.h, [592](#)
IOOBJID_AIN_MFG_VALUE
CML_IO.h, [591](#)
IOOBJID_AIN_TRIG
CML_IO.h, [592](#)
IOOBJID_AIN_UNIT
CML_IO.h, [592](#)
IOOBJID_AOUT_16_VALUE
CML_IO.h, [592](#)
IOOBJID_AOUT_32_ERRVAL
CML_IO.h, [592](#)
IOOBJID_AOUT_32_OFFSET
CML_IO.h, [592](#)
IOOBJID_AOUT_32_SCALE
CML_IO.h, [592](#)
IOOBJID_AOUT_32_VALUE
CML_IO.h, [592](#)
IOOBJID_AOUT_8_VALUE
CML_IO.h, [592](#)
IOOBJID_AOUT_ERRMODE
CML_IO.h, [592](#)
IOOBJID_AOUT_FLT_ERRVAL
CML_IO.h, [592](#)
IOOBJID_AOUT_FLT_OFFSET
CML_IO.h, [592](#)
IOOBJID_AOUT_FLT_SCALE
CML_IO.h, [592](#)
IOOBJID_AOUT_FLT_VALUE
CML_IO.h, [592](#)
IOOBJID_AOUT_MFG_VALUE
CML_IO.h, [592](#)
IOOBJID_AOUT_UNIT
CML_IO.h, [592](#)
IOOBJID_DIN_16_FILT
CML_IO.h, [591](#)
IOOBJID_DIN_16_MASK_ANY
CML_IO.h, [591](#)
IOOBJID_DIN_16_MASK_H2L
CML_IO.h, [591](#)
IOOBJID_DIN_16_MASK_L2H
CML_IO.h, [591](#)
IOOBJID_DIN_16_POL
CML_IO.h, [591](#)
IOOBJID_DIN_16_VALUE
CML_IO.h, [591](#)
IOOBJID_DIN_1_FILT
CML_IO.h, [591](#)
IOOBJID_DIN_1_MASK_ANY
CML_IO.h, [591](#)
IOOBJID_DIN_1_MASK_H2L
CML_IO.h, [591](#)
IOOBJID_DIN_1_MASK_L2H
CML_IO.h, [591](#)
IOOBJID_DIN_1_POL
CML_IO.h, [591](#)
IOOBJID_DIN_1_VALUE
CML_IO.h, [590](#)
IOOBJID_DIN_32_FILT
CML_IO.h, [591](#)
IOOBJID_DIN_32_MASK_ANY
CML_IO.h, [591](#)
IOOBJID_DIN_32_MASK_H2L
CML_IO.h, [591](#)
IOOBJID_DIN_32_MASK_L2H
CML_IO.h, [591](#)
IOOBJID_DIN_32_POL
CML_IO.h, [591](#)
IOOBJID_DIN_32_VALUE
CML_IO.h, [591](#)
IOOBJID_DIN_8_FILT
CML_IO.h, [590](#)
IOOBJID_DIN_8_MASK_ANY
CML_IO.h, [590](#)
IOOBJID_DIN_8_MASK_H2L
CML_IO.h, [590](#)
IOOBJID_DIN_8_MASK_L2H
CML_IO.h, [590](#)
IOOBJID_DIN_8_POL
CML_IO.h, [590](#)
IOOBJID_DIN_8_VALUE
CML_IO.h, [590](#)
IOOBJID_DIN_INTENA
CML_IO.h, [590](#)
IOOBJID_DOUT_16_ERRMODE

- CML_IO.h, [591](#)
- IOOBJID_DOUT_16_ERRVAL
 - CML_IO.h, [591](#)
- IOOBJID_DOUT_16_FILT
 - CML_IO.h, [591](#)
- IOOBJID_DOUT_16_POL
 - CML_IO.h, [591](#)
- IOOBJID_DOUT_16_VALUE
 - CML_IO.h, [591](#)
- IOOBJID_DOUT_1_ERRMODE
 - CML_IO.h, [591](#)
- IOOBJID_DOUT_1_ERRVAL
 - CML_IO.h, [591](#)
- IOOBJID_DOUT_1_FILT
 - CML_IO.h, [591](#)
- IOOBJID_DOUT_1_POL
 - CML_IO.h, [591](#)
- IOOBJID_DOUT_1_VALUE
 - CML_IO.h, [591](#)
- IOOBJID_DOUT_32_ERRMODE
 - CML_IO.h, [591](#)
- IOOBJID_DOUT_32_ERRVAL
 - CML_IO.h, [591](#)
- IOOBJID_DOUT_32_FILT
 - CML_IO.h, [591](#)
- IOOBJID_DOUT_32_POL
 - CML_IO.h, [591](#)
- IOOBJID_DOUT_32_VALUE
 - CML_IO.h, [591](#)
- IOOBJID_DOUT_8_ERRMODE
 - CML_IO.h, [591](#)
- IOOBJID_DOUT_8_ERRVAL
 - CML_IO.h, [591](#)
- IOOBJID_DOUT_8_FILT
 - CML_IO.h, [591](#)
- IOOBJID_DOUT_8_POL
 - CML_IO.h, [591](#)
- IOOBJID_DOUT_8_VALUE
 - CML_IO.h, [591](#)
- INPUT_PIN_CONFIG
 - CML_AmpDef.h, [559](#)
- IO_AIN_TRIG_TYPE
 - CML_IO.h, [590](#)
- IO_OBJID
 - CML_IO.h, [590](#)
- IOError, [281](#)
- IOFileError, [283](#)
- IOMODULE_EVENTS
 - CML_IO.h, [592](#)
- IOModule, [284](#)
 - Ain16GetCt, [295](#)
 - Ain16GetLowerLimit, [295](#)
 - Ain16GetNegativeDelta, [295](#)
 - Ain16GetPositiveDelta, [295](#)
 - Ain16GetUnsignedDelta, [296](#)
 - Ain16GetUpperLimit, [296](#)
 - Ain16Read, [296](#)
 - Ain16SetLowerLimit, [296](#)
 - Ain16SetNegativeDelta, [297](#)
 - Ain16SetPositiveDelta, [297](#)
 - Ain16SetUnsignedDelta, [297](#)
 - Ain16SetUpperLimit, [298](#)
 - Ain32GetCt, [298](#)
 - Ain32GetLowerLimit, [298](#)
 - Ain32GetNegativeDelta, [298](#)
 - Ain32GetOffset, [300](#)
 - Ain32GetPositiveDelta, [300](#)
 - Ain32GetScaling, [300](#)
 - Ain32GetUnsignedDelta, [300](#)
 - Ain32GetUpperLimit, [301](#)
 - Ain32Read, [301](#)
 - Ain32SetLowerLimit, [301](#)
 - Ain32SetNegativeDelta, [301](#)
 - Ain32SetOffset, [303](#)
 - Ain32SetPositiveDelta, [303](#)
 - Ain32SetScaling, [303](#)
 - Ain32SetUnsignedDelta, [303](#)
 - Ain32SetUpperLimit, [304](#)
 - Ain8GetCt, [304](#)
 - Ain8Read, [304](#)
 - AinFiltGetCt, [304](#)
 - AinFiltGetLowerLimit, [305](#)
 - AinFiltGetNegativeDelta, [305](#)
 - AinFiltGetOffset, [305](#)
 - AinFiltGetPositiveDelta, [305](#)
 - AinFiltGetScaling, [307](#)
 - AinFiltGetUnsignedDelta, [307](#)
 - AinFiltGetUpperLimit, [307](#)
 - AinFiltRead, [307](#)
 - AinFiltSetLowerLimit, [308](#)
 - AinFiltSetNegativeDelta, [308](#)
 - AinFiltSetOffset, [308](#)
 - AinFiltSetPositiveDelta, [308](#)
 - AinFiltSetScaling, [310](#)
 - AinFiltSetUnsignedDelta, [310](#)
 - AinFiltSetUpperLimit, [310](#)
 - AinGetIntEna, [310](#)
 - AinGetIntSource, [312](#)
 - AinGetTrigType, [312](#)
 - AinSetIntEna, [312](#)
 - AinSetTrigType, [312](#)
 - Aout16GetCt, [314](#)
 - Aout16GetErrValue, [314](#)
 - Aout16SetErrValue, [314](#)
 - Aout16Write, [314](#)
 - Aout32GetCt, [316](#)
 - Aout32GetErrValue, [316](#)
 - Aout32GetOffset, [316](#)

Aout32GetScaling, 316
Aout32SetErrValue, 317
Aout32SetOffset, 317
Aout32SetScaling, 317
Aout32Write, 317
Aout8GetCt, 318
Aout8Write, 318
AoutFltGetCt, 318
AoutFltGetErrValue, 318
AoutFltGetOffset, 319
AoutFltGetScaling, 319
AoutFltSetErrValue, 319
AoutFltSetOffset, 319
AoutFltSetScaling, 320
AoutFltWrite, 320
AoutGetErrMode, 320
AoutSetErrMode, 320
BitCount, 321
BitDnld, 321
BitUpld, 321
Din16GetCt, 322
Din16GetFilt, 322
Din16GetMaskAny, 322
Din16GetMaskHigh2Low, 322
Din16GetMaskLow2High, 323
Din16GetPol, 323
Din16Read, 323
Din16SetFilt, 324
Din16SetMaskAny, 324
Din16SetMaskHigh2Low, 324
Din16SetMaskLow2High, 325
Din16SetPol, 325
Din32GetCt, 325
Din32GetFilt, 325
Din32GetMaskAny, 326
Din32GetMaskHigh2Low, 326
Din32GetMaskLow2High, 326
Din32GetPol, 327
Din32Read, 327
Din32SetFilt, 327
Din32SetMaskAny, 327
Din32SetMaskHigh2Low, 329
Din32SetMaskLow2High, 329
Din32SetPol, 329
Din8GetCt, 329
Din8GetFilt, 331
Din8GetMaskAny, 331
Din8GetMaskHigh2Low, 331
Din8GetMaskLow2High, 331
Din8GetPol, 332
Din8Read, 332
Din8SetFilt, 332
Din8SetMaskAny, 333
Din8SetMaskHigh2Low, 333
Din8SetMaskLow2High, 333
Din8SetPol, 333
DinGetCt, 334
DinGetFilt, 334
DinGetIntEna, 334
DinGetMaskAny, 335
DinGetMaskHigh2Low, 335
DinGetMaskLow2High, 335
DinGetPol, 335
DinRead, 337
DinSetFilt, 337
DinSetIntEna, 337
DinSetMaskAny, 337
DinSetMaskHigh2Low, 338
DinSetMaskLow2High, 338
DinSetPol, 338
Dout16GetCt, 339
Dout16GetErrMode, 339
Dout16GetErrValue, 339
Dout16GetFilt, 339
Dout16GetPol, 340
Dout16Read, 340
Dout16SetErrMode, 340
Dout16SetErrValue, 341
Dout16SetFilt, 341
Dout16SetPol, 341
Dout16Write, 341
Dout32GetCt, 342
Dout32GetErrMode, 342
Dout32GetErrValue, 342
Dout32GetFilt, 343
Dout32GetPol, 343
Dout32Read, 343
Dout32SetErrMode, 343
Dout32SetErrValue, 344
Dout32SetFilt, 344
Dout32SetPol, 344
Dout32Write, 345
Dout8GetCt, 345
Dout8GetErrMode, 345
Dout8GetErrValue, 346
Dout8GetFilt, 346
Dout8GetPol, 346
Dout8Read, 346
Dout8SetErrMode, 348
Dout8SetErrValue, 348
Dout8SetFilt, 348
Dout8SetPol, 349
Dout8Write, 349
DoutGetCt, 349
DoutGetErrMode, 349
DoutGetErrValue, 350
DoutGetFilt, 350
DoutGetPol, 350

- DoutSetErrMode, [351](#)
- DoutSetErrValue, [351](#)
- DoutSetFilt, [351](#)
- DoutSetPol, [352](#)
- DoutWrite, [352](#)
- IOModule, [294](#)
- Init, [352](#), [353](#)
- IOModule, [294](#)
- PostIOEvent, [353](#)
- WaitIOEvent, [353](#), [354](#)
- IOModule::AlgInPDO, [23](#)
 - GetInVal, [24](#)
 - Init, [25](#)
 - Received, [25](#)
- IOModule::AlgOutPDO, [26](#)
 - Init, [28](#)
 - Transmit, [28](#)
 - Update, [28](#)
- IOModule::DigInPDO, [224](#)
 - GetBitVal, [225](#)
 - GetInVal, [227](#)
 - Init, [227](#)
 - Received, [227](#)
- IOModule::DigOutPDO, [228](#)
 - Init, [229](#)
 - Transmit, [231](#)
 - Update, [231](#)
 - UpdateBit, [231](#)
- IOModuleSettings, [354](#)
 - guardTime, [355](#)
 - heartbeatPeriod, [355](#)
 - heartbeatTimeout, [355](#)
 - lifeFactor, [355](#)
 - useStandardAinPDO, [356](#)
 - useStandardAoutPDO, [356](#)
 - useStandardDinPDO, [356](#)
 - useStandardDoutPDO, [356](#)
- IOModule.cpp, [622](#)
- id
 - CanFrame, [173](#)
- IllegalFieldCt
 - CanOpenError, [192](#)
- inCfg
 - AmploCfg, [157](#)
- inPullUpCfg
 - AmploCfg, [157](#)
- inPullUpCfg32
 - AmploCfg, [157](#)
- Init
 - Amp, [96](#), [97](#)
 - CopleyIO, [204](#)
 - EcatDgram, [234](#)
 - IOModule, [352](#), [353](#)
 - IOModule::AlgInPDO, [25](#)
 - IOModule::AlgOutPDO, [28](#)
 - IOModule::DigInPDO, [227](#)
 - IOModule::DigOutPDO, [229](#)
 - Linkage, [378](#)
 - Node, [416](#)
 - Pmap, [441](#)
 - Pmap16, [443](#)
 - Pmap24, [446](#)
 - Pmap32, [449](#)
 - Pmap8, [452](#)
 - RPDO, [480](#)
 - RPDO_LinkCtrl, [482](#)
 - SDO, [492](#)
- InitDistClk
 - EtherCAT, [246](#)
- InitSubAxis
 - Amp, [97](#)
- initialMode
 - AmpSettings, [160](#)
- Initialized
 - CanOpenError, [192](#)
- inputCt
 - AmploCfg, [157](#)
- InputShaper, [280](#)
 - InputShaper, [281](#)
 - InputShaper, [281](#)
 - LoadFromCCX, [281](#)
- InputShaper.cpp, [622](#)
- int16
 - CML_Utils.h, [615](#)
- int32
 - CML_Utils.h, [615](#)
- int64
 - CML_Utils.h, [615](#)
- IsHardwareEnabled
 - Amp, [97](#)
- IsReferenced
 - Amp, [97](#)
- IsSoftwareEnabled
 - Amp, [98](#)
- isTrue
 - Event, [256](#)
 - EventAll, [259](#)
 - EventAny, [261](#)
 - EventAnyClear, [264](#)
 - EventNone, [270](#)
- IxxatCAN, [356](#)
 - ~IxxatCAN, [359](#)
 - channel, [362](#)
 - Close, [359](#)
 - ConvertError, [359](#)
 - IxxatCAN, [358](#)
 - IxxatCAN, [358](#)
 - Open, [359](#)

- RecvFrame, [359](#)
- rxInt, [361](#)
- SetBaud, [361](#)
- XmitFrame, [361](#)
- IxxatCANV3, [362](#)
 - channel, [365](#)
 - Close, [364](#)
 - ConvertError, [364](#)
 - Open, [364](#)
 - RecvFrame, [364](#)
 - SetBaud, [365](#)
 - XmitFrame, [365](#)
- jrk
 - ProfileConfigScurve, [462](#)
- JrkLoad2User
 - Amp, [98](#)
- JrkUser2Load
 - Amp, [98](#)
- KillRef
 - RefObj, [472](#)
- KvaserCAN, [366](#)
 - ~KvaserCAN, [368](#)
 - Close, [368](#)
 - ConvertError, [368](#)
 - KvaserCAN, [367](#)
 - KvaserCAN, [367](#)
 - Open, [368](#)
 - RecvFrame, [368](#)
 - SetBaud, [370](#)
 - XmitFrame, [370](#)
- LINKEVENT_ABORT
 - CML_Linkage.h, [595](#)
- LINKEVENT_DISABLED
 - CML_Linkage.h, [594](#)
- LINKEVENT_ERROR
 - CML_Linkage.h, [594](#)
- LINKEVENT_FAULT
 - CML_Linkage.h, [594](#)
- LINKEVENT_MOVEDONE
 - CML_Linkage.h, [594](#)
- LINKEVENT_NEGLIM
 - CML_Linkage.h, [594](#)
- LINKEVENT_NODEGUARD
 - CML_Linkage.h, [594](#)
- LINKEVENT_POSLIM
 - CML_Linkage.h, [594](#)
- LINKEVENT_POSWARN
 - CML_Linkage.h, [594](#)
- LINKEVENT_POSWIN
 - CML_Linkage.h, [594](#)
- LINKEVENT_QUICKSTOP
 - CML_Linkage.h, [595](#)
- LINKEVENT_SOFTLIM_NEG
 - CML_Linkage.h, [595](#)
- LINKEVENT_SOFTLIM_POS
 - CML_Linkage.h, [595](#)
- LINKEVENT_TRJDONE
 - CML_Linkage.h, [594](#)
- LINKEVENT_VELWIN
 - CML_Linkage.h, [594](#)
- LOG_CAN
 - CML.h, [538](#)
- LOG_DEBUG
 - CML.h, [538](#)
- LOG_ERRORS
 - CML.h, [538](#)
- LOG_EVERYTHING
 - CML.h, [538](#)
- LOG_FILT_CAN
 - CML.h, [538](#)
- LOG_NONE
 - CML.h, [538](#)
- LOG_WARNINGS
 - CML.h, [538](#)
- LINK_EVENT
 - CML_Linkage.h, [594](#)
- LSS, [392](#)
 - FindAmpSerial, [395](#)
 - FindAmplifiers, [394](#)
 - GetAmpNodeID, [395](#)
 - getTimeout, [395](#)
 - LSS, [394](#)
 - LSS, [394](#)
 - NewFrame, [395](#)
 - SelectAmp, [397](#)
 - SetAmpNodeID, [397](#)
 - setTimeout, [397](#)
 - Xmit, [397](#)
- length
 - Array, [167](#)
 - CanFrame, [173](#)
- lifeFactor
 - AmpSettings, [160](#)
 - IOModuleSettings, [355](#)
- limitBitMask
 - AmpConfig, [145](#)
- LinkError, [381](#)
 - NetworkMismatch, [383](#)
 - NotSupported, [383](#)
- LinkSettings, [384](#)
 - haltOnPosWarn, [384](#)
 - haltOnVelWin, [384](#)
 - LinkSettings, [384](#)
 - LinkSettings, [384](#)
 - moveAckTimeout, [384](#)
- LinkTrajectory, [385](#)

- Finish, [387](#)
- GetDim, [387](#)
- MaximumBufferPointsToUse, [387](#)
- NextSegment, [387](#)
- StartNew, [388](#)
- UseVelocityInfo, [388](#)
- LinkTrjScurve, [388](#)
 - Calculate, [390](#)
 - GetDim, [390](#)
 - NextSegment, [390](#)
 - StartNew, [391](#)
- Linkage, [370](#)
 - ClearLatchedError, [373](#)
 - Configure, [373](#)
 - ConvertAmpToAxis, [373](#)
 - ConvertAmpToAxisPos, [374](#)
 - ConvertAxisToAmp, [374](#)
 - ConvertAxisToAmpPos, [374](#)
 - GetAmp, [376](#)
 - GetAmpCount, [376](#)
 - GetAmpRef, [376](#)
 - GetAxesCount, [376](#)
 - GetLatchedError, [377](#)
 - GetMoveLimits, [377](#)
 - GetPositionCommand, [377](#)
 - HaltMove, [377](#)
 - Init, [378](#)
 - Linkage, [373](#)
 - MoveTo, [378](#), [379](#)
 - SendTrajectory, [380](#)
 - SetMoveLimits, [380](#)
 - StartMove, [380](#)
 - WaitEvent, [380](#), [381](#)
 - WaitMoveDone, [381](#)
- Linkage.cpp, [623](#)
- LinuxEcatHardware, [391](#)
- Load
 - EcatDgram, [235](#)
- LoadData
 - RPDO, [480](#)
- loadEncOptions
 - MtrInfo, [400](#)
- loadEncRes
 - MtrInfo, [400](#)
- loadEncType
 - MtrInfo, [401](#)
- LoadFromCCX
 - Filter, [271](#)
 - InputShaper, [281](#)
- LoadFromFile
 - Amp, [99](#)
 - CopleyIO, [204](#)
- local
 - CopleyCAN, [199](#)
- Lock
 - Mutex, [402](#)
- LockRef
 - RefObj, [472](#)
- LogCAN
 - CopleyMotionLibrary, [215](#)
- LogRefs
 - RefObj, [472](#)
- Lookup
 - Error, [240](#)
- macroEncoderCapture
 - SoftPosLimit, [501](#)
- MailboxTransfer
 - EtherCAT, [246](#)
- map
 - PDO, [437](#)
- maxAcc
 - VelLoopConfig, [520](#)
- maxDec
 - VelLoopConfig, [520](#)
- maxPvtSendCt
 - AmpSettings, [160](#)
- maxSdoFromNode
 - EtherCAT, [246](#)
 - Network, [405](#)
 - Node, [416](#)
- maxSdoToNode
 - EtherCAT, [248](#)
 - Network, [405](#)
 - Node, [416](#)
- maxVel
 - VelLoopConfig, [520](#)
- maxVelAdj
 - UstepConfig, [518](#)
- MaximumBufferPointsToUse
 - LinkTrajectory, [387](#)
 - Trajectory, [511](#)
- model
 - RegenConfig, [476](#)
- MonitorRunning
 - CanOpenError, [192](#)
- motorPosWrap
 - SoftPosLimit, [501](#)
- MoveAbs
 - Amp, [99](#)
- moveAckTimeout
 - LinkSettings, [384](#)
- MoveRel
 - Amp, [99](#)
- MoveTo
 - Linkage, [378](#), [379](#)
- mtrEncOptions
 - MtrInfo, [401](#)

- MtrInfo, 398
 - gearRatio, 400
 - hallVelShift, 400
 - loadEncOptions, 400
 - loadEncRes, 400
 - loadEncType, 401
 - mtrEncOptions, 401
 - MtrInfo, 400
 - MtrInfo, 400
 - poles, 401
 - resolverCycles, 401
- Mutex, 401
 - Lock, 402
 - Unlock, 402
- MutexLocker, 402
 - MutexLocker, 403
 - MutexLocker, 403
- NET_TYPE_CANOPEN
 - CML_Network.h, 598
- NET_TYPE_ETHERCAT
 - CML_Network.h, 598
- NET_TYPE_INVALID
 - CML_Network.h, 598
- NODESTATE_GUARDERR
 - CML_Network.h, 598
- NODESTATE_INVALID
 - CML_Network.h, 598
- NODESTATE_OPERATIONAL
 - CML_Network.h, 598
- NODESTATE_PRE_OP
 - CML_Network.h, 598
- NODESTATE_SAFE_OP
 - CML_Network.h, 598
- NODESTATE_STOPPED
 - CML_Network.h, 598
- NODESTATE_UNKNOWN
 - CML_Network.h, 598
- neg
 - SoftPosLimit, 501
- Network, 403
 - GetNodeInfo, 404
 - maxSdoFromNode, 405
 - maxSdoToNode, 405
 - SetNodeInfo, 405
- Network.cpp, 624
- NetworkError, 406
- NetworkMismatch
 - LinkError, 383
- NetworkNodeInfo, 407
- NetworkOptions, 407
 - NetworkOptions, 408
 - NetworkOptions, 408
- NetworkType
 - CML_Network.h, 597
- NewFrame
 - LSS, 395
 - Receiver, 469
- NextSegment
 - LinkTrajectory, 387
 - LinkTrjScurve, 390
 - Path, 426
 - Trajectory, 512
- Node, 408
 - ClearErrorHistory, 412
 - GetDeviceType, 412
 - GetErrorHistory, 412
 - GetErrorRegister, 412
 - GetIdentity, 413
 - GetMfgDeviceName, 413
 - GetMfgHardwareVer, 413
 - GetMfgSoftwareVer, 413
 - GetMfgStatus, 414
 - GetNetworkRef, 414
 - GetNetworkType, 414
 - GetNodeID, 414
 - GetState, 414
 - GetSynchId, 415
 - GetSynchPeriod, 415
 - HandleEmergency, 415
 - HandleStateChange, 415
 - Init, 416
 - maxSdoFromNode, 416
 - maxSdoToNode, 416
 - Node, 411
 - PdoDisable, 416
 - PdoEnable, 417
 - PdoSet, 417
 - PreOpNode, 417
 - ResetComm, 417
 - ResetNode, 417
 - RpdoDisable, 418
 - sdo, 420
 - SetSynchId, 418
 - SetSynchPeriod, 418
 - StartHeartbeat, 418
 - StartNode, 419
 - StartNodeGuard, 419
 - StopGuarding, 419
 - StopNode, 419
 - SynchStart, 419
 - SynchStop, 420
 - TpdoDisable, 420
 - UnInit, 420
- Node.cpp, 624
- NodeError, 421
- nodeGuard
 - CanNetworkConfig, 181

- nodeGuardLife
 - CanNetworkConfig, [181](#)
- NodeIdentity, [422](#)
- NodeState
 - CML_Network.h, [598](#)
- NoneAvailable
 - TrjError, [514](#)
- NotInitialized
 - CanOpenError, [192](#)
- NotSupported
 - LinkError, [383](#)
- numInPins
 - CanNetworkConfig, [181](#)

- OUTCFG_ACTIVE_HIGH
 - CML_AmpDef.h, [561](#)
- OUTCFG_EVENT_LATCH_H
 - CML_AmpDef.h, [561](#)
- OUTCFG_EVENT_LATCH_L
 - CML_AmpDef.h, [561](#)
- OUTCFG_EVENT_STATUS_H
 - CML_AmpDef.h, [560](#)
- OUTCFG_EVENT_STATUS_L
 - CML_AmpDef.h, [560](#)
- OUTCFG_MANUAL_H
 - CML_AmpDef.h, [561](#)
- OUTCFG_MANUAL_L
 - CML_AmpDef.h, [561](#)
- OUTCFG_POSITION_TRIG
 - CML_AmpDef.h, [561](#)
- OUTCFG_POSITION_TRIG_HIGH2LOW
 - CML_AmpDef.h, [561](#)
- OUTCFG_POSITION_TRIG_LIST
 - CML_AmpDef.h, [561](#)
- OUTCFG_POSITION_TRIG_LOW2HIGH
 - CML_AmpDef.h, [561](#)
- OUTCFG_POSITION_WINDOW
 - CML_AmpDef.h, [561](#)
- OUTCFG_SYNC_OUTPUT
 - CML_AmpDef.h, [561](#)
- OUTCFG_TRJ_STATUS
 - CML_AmpDef.h, [561](#)
- offset
 - CanNetworkConfig, [181](#)
 - HomeConfig, [280](#)
- Open
 - CanInterface, [176](#)
 - CanOpen, [186](#)
 - CopleyCAN, [198](#)
 - IxxatCAN, [359](#)
 - IxxatCANV3, [364](#)
 - KvaserCAN, [368](#)
- operator*
 - RefObjLocker, [475](#)
- operator->
 - RefObjLocker, [475](#)
- operator=
 - Event, [256](#)
- options
 - AmpConfig, [145](#)
- outMask
 - AmploCfg, [157](#)
- outMask1
 - AmploCfg, [157](#)
- outputCt
 - AmploCfg, [157](#)

- PHASE_MODE_AHALL90
 - CML_AmpDef.h, [553](#)
- PHASE_MODE_BRUSHED
 - CML_AmpDef.h, [553](#)
- PHASE_MODE_ENCODER
 - CML_AmpDef.h, [553](#)
- PHASE_MODE_ENCPHASE
 - CML_AmpDef.h, [553](#)
- PHASE_MODE_NOADJUST
 - CML_AmpDef.h, [553](#)
- PHASE_MODE_NOHALL
 - CML_AmpDef.h, [553](#)
- PHASE_MODE_TRAP
 - CML_AmpDef.h, [553](#)
- PHASE_MODE_TRAPINTERP
 - CML_AmpDef.h, [553](#)
- PROFILE_CSP
 - CML_AmpDef.h, [563](#)
- PROFILE_SCURVE
 - CML_AmpDef.h, [563](#)
- PROFILE_TRAP
 - CML_AmpDef.h, [562](#)
- PROFILE_VEL
 - CML_AmpDef.h, [562](#)
- PWM_MODE_AUTOCLAMP
 - CML_AmpDef.h, [553](#)
- PWM_MODE_FORCECLAMP
 - CML_AmpDef.h, [553](#)
- PWM_MODE_HEXLIMIT
 - CML_AmpDef.h, [553](#)
- PWM_MODE_STANDARD
 - CML_AmpDef.h, [553](#)
- PDO, [433](#)
 - AddVar, [436](#)
 - ClearMap, [436](#)
 - GetID, [436](#)
 - GetMapCodes, [436](#)
 - GetRtrOk, [436](#)
 - GetType, [437](#)
 - map, [437](#)
 - SetID, [437](#)

- SetType, [437](#)
- PDO.cpp, [625](#)
- PDO_Error, [438](#)
 - BitOverflow, [439](#)
- POS_CAPTURE_CFG
 - CML_AmpDef.h, [561](#)
- POS_CAPTURE_STAT
 - CML_AmpDef.h, [562](#)
- PROFILE_TYPE
 - CML_AmpDef.h, [562](#)
- Path, [423](#)
 - AddArc, [425](#)
 - AddLine, [425](#)
 - GetDim, [426](#)
 - NextSegment, [426](#)
 - Path, [424](#)
 - Pause, [426](#)
 - PlayPath, [427](#)
 - Reset, [427](#)
 - SetAcc, [427](#)
 - SetDec, [427](#)
 - SetJrk, [428](#)
 - SetStartPos, [428](#)
 - SetVel, [428](#)
 - StartNew, [429](#)
- PathError, [429](#)
- Pause
 - Path, [426](#)
- PcapEcatHardware, [431](#)
 - GetAdapterDesc, [433](#)
 - GetAdapterName, [433](#)
 - PcapEcatHardware, [432](#)
 - PcapEcatHardware, [432](#)
- PdoDisable
 - Node, [416](#)
- PdoEnable
 - Node, [417](#)
- PdoSet
 - Node, [417](#)
- peakPower
 - RegenConfig, [476](#)
- peakTime
 - CrntLoopConfig, [222](#)
 - RegenConfig, [476](#)
- phaseInitConfig
 - AlgoPhaseInit, [26](#)
- phaseMode
 - AmpConfig, [145](#)
- pinMapping
 - CanNetworkConfig, [181](#)
- PlayPath
 - Path, [427](#)
- Pmap, [439](#)
 - Get, [440](#)
 - GetBits, [441](#)
 - GetIndex, [441](#)
 - GetSub, [441](#)
 - Init, [441](#)
 - Pmap, [440](#)
 - Set, [441](#)
- Pmap16, [442](#)
 - Get, [443](#)
 - Init, [443](#)
 - Pmap16, [443](#)
 - Read, [444](#)
 - Set, [444](#)
 - Write, [444](#)
- Pmap24, [444](#)
 - Get, [446](#)
 - Init, [446](#)
 - Pmap24, [446](#)
 - Read, [446](#)
 - Set, [446](#)
 - Write, [447](#)
- Pmap32, [447](#)
 - Get, [449](#)
 - Init, [449](#)
 - Pmap32, [448](#)
 - Read, [449](#)
 - Set, [449](#)
 - Write, [449](#)
- Pmap8, [451](#)
 - Get, [452](#)
 - Init, [452](#)
 - Pmap8, [452](#)
 - Read, [453](#)
 - Set, [453](#)
 - Write, [453](#)
- PmapRaw, [453](#)
 - Get, [455](#)
 - PmapRaw, [455](#)
 - PmapRaw, [455](#)
 - Set, [455](#)
- Point
 - getDim, [457](#)
 - getMax, [457](#)
 - setDim, [457](#)
- Point< N >, [455](#)
- PointN, [457](#)
 - getDim, [458](#)
 - getMax, [458](#)
 - setDim, [459](#)
- poles
 - MtrInfo, [401](#)
- portName
 - CanInterface, [178](#)
- pos
 - ProfileConfig, [461](#)

- ProfileConfigScurve, 462
- ProfileConfigTrap, 463
- SoftPosLimit, 501
- PosLoad2User
 - Amp, 99
- PosLoopConfig, 459
 - PosLoopConfig, 460
 - PosLoopConfig, 460
 - scale, 460
- PosMtr2User
 - Amp, 100
- PosUser2Load
 - Amp, 100
- PosUser2Mtr
 - Amp, 100
- PostIOEvent
 - IOModule, 353
- PreOpNode
 - CanOpen, 187
 - Node, 417
- ProcessData
 - TPDO, 508
- ProfileConfig, 460
 - abort, 461
 - pos, 461
- ProfileConfigScurve, 461
 - acc, 462
 - jrk, 462
 - pos, 462
 - vel, 462
- ProfileConfigTrap, 462
 - acc, 463
 - dec, 463
 - pos, 463
 - vel, 463
- ProfileConfigVel, 464
 - acc, 464
 - dec, 464
 - dir, 464
 - vel, 464
- progCrnt
 - AmpConfig, 145
- progVel
 - AmpConfig, 145
- progress
 - Firmware, 273
- Put
 - Semaphore, 499
- PvtBufferFlush
 - Amp, 101
- PvtBufferPop
 - Amp, 101
- PvtClearErrors
 - Amp, 101
- PvtSegCache, 465
 - AddSegment, 465
 - GetPosition, 466
 - GetSegment, 466
- PvtStatusUpdate
 - Amp, 102
- PvtWriteBuff
 - Amp, 102
- PwmInConfig, 466
 - cfg, 467
 - freq, 467
 - scale, 467
 - uvCfg, 467
- pwmMode
 - AmpConfig, 145
- QSTOP_ABRUPT
 - CML_AmpDef.h, 563
- QSTOP_ABRUPT_HOLD
 - CML_AmpDef.h, 563
- QSTOP_DECEL
 - CML_AmpDef.h, 563
- QSTOP_DECEL_HOLD
 - CML_AmpDef.h, 563
- QSTOP_DISABLE
 - CML_AmpDef.h, 563
- QSTOP_QUICKSTOP
 - CML_AmpDef.h, 563
- QSTOP_QUICKSTOP_HOLD
 - CML_AmpDef.h, 563
- QUICK_STOP_MODE
 - CML_AmpDef.h, 563
- QuickStop
 - Amp, 102
- RPDO, 477
 - Init, 480
 - LoadData, 480
 - RPDO, 478
 - RPDO, 478
- RPDO_LinkCtrl, 480
 - Init, 482
 - Transmit, 482
- Relnit
 - Amp, 103
- Read
 - Pmap16, 444
 - Pmap24, 446
 - Pmap32, 449
 - Pmap8, 453
- readThreadPriority
 - CanOpenSettings, 195
 - EtherCatSettings, 253
- Received
 - IOModule::AlInPDO, 25

- IOModule::DigInPDO, [227](#)
- TPDO, [508](#)
- Receiver, [468](#)
 - ~Receiver, [469](#)
 - NewFrame, [469](#)
- Recv
 - CanInterface, [176](#)
- RecvFrame
 - CanInterface, [177](#)
 - CopleyCAN, [198](#)
 - IxxatCAN, [359](#)
 - IxxatCANV3, [364](#)
 - KvaserCAN, [368](#)
- RefObj, [469](#)
 - ~RefObj, [471](#)
 - GrabRef, [472](#)
 - KillRef, [472](#)
 - LockRef, [472](#)
 - LogRefs, [472](#)
 - RefObj, [471](#)
 - RefObj, [471](#)
 - ReleaseRef, [472](#)
 - setAutoDelete, [474](#)
 - SetRefName, [474](#)
- RefObjLocker
 - operator*, [475](#)
 - operator->, [475](#)
 - RefObjLocker, [475](#)
 - RefObjLocker, [475](#)
- RefObjLocker< RefClass >, [474](#)
- Reference.cpp, [625](#)
- RegenConfig, [475](#)
 - contPower, [476](#)
 - model, [476](#)
 - peakPower, [476](#)
 - peakTime, [476](#)
 - RegenConfig, [476](#)
 - RegenConfig, [476](#)
 - vOff, [477](#)
 - vOn, [477](#)
- ReleaseRef
 - RefObj, [472](#)
- rem
 - Array, [167](#)
- Remove
 - EventMap, [267](#)
- Reset
 - Amp, [103](#)
 - Path, [427](#)
- ResetComm
 - CanOpen, [187](#)
 - Node, [417](#)
- ResetNode
 - CanOpen, [187](#)
 - Node, [417](#)
- resetOnInit
 - AmpSettings, [161](#)
- resolverCycles
 - MtrlInfo, [401](#)
- RpdoDisable
 - Node, [418](#)
- run
 - Thread, [503](#)
- rxInt
 - IxxatCAN, [361](#)
- SDO, [484](#)
 - BlockDnld, [486](#)
 - BlockUpld, [486](#)
 - DisableBlkDnld, [486](#)
 - DisableBlkUpld, [486](#)
 - Dnld16, [486](#), [488](#)
 - Dnld32, [488](#)
 - Dnld8, [488](#), [490](#)
 - DnldFlt, [490](#)
 - DnldString, [490](#)
 - Download, [491](#)
 - EnableBlkDnld, [491](#)
 - EnableBlkUpld, [491](#)
 - GetMaxRetry, [492](#)
 - GetTimeout, [492](#)
 - Init, [492](#)
 - SDO, [485](#)
 - SDO, [485](#)
 - SetTimeout, [492](#)
 - Upld16, [492](#), [493](#)
 - Upld32, [493](#)
 - Upld8, [493](#), [494](#)
 - UpldFlt, [494](#)
 - UpldString, [494](#)
 - Upload, [495](#)
- SDO.cpp, [626](#)
- SDO_BadMuxRcvd
 - CanOpenError, [192](#)
- SDO_Error, [496](#)
- SM_RXMBX
 - EtherCAT.cpp, [618](#)
- SaveAmpConfig
 - Amp, [103](#)
- SaveIOConfig
 - CopleyIO, [205](#)
- scale
 - AnalogRefConfig, [162](#)
 - PosLoopConfig, [460](#)
 - PwmInConfig, [467](#)
- ScurveError, [482](#)
- sdo
 - Node, [420](#)

- SelectAmp
 - LSS, [397](#)
- Semaphore, [498](#)
 - ~Semaphore, [499](#)
 - Get, [499](#)
 - Put, [499](#)
 - Semaphore, [499](#)
- SendTrajectory
 - Amp, [103](#)
 - Linkage, [380](#)
- SerialCmd
 - CopleyIO, [205](#)
 - CopleyNode, [219](#)
- ServoLoopConfig, [500](#)
 - servoLoopConfig, [500](#)
- servoLoopConfig
 - ServoLoopConfig, [500](#)
- Set
 - Pmap, [441](#)
 - Pmap16, [444](#)
 - Pmap24, [446](#)
 - Pmap32, [449](#)
 - Pmap8, [453](#)
 - PmapRaw, [455](#)
- SetAcc
 - Path, [427](#)
- SetAlgoPhaseInit
 - Amp, [105](#)
- SetAmpConfig
 - Amp, [105](#)
- SetAmpMode
 - Amp, [105](#)
- SetAmpName
 - Amp, [106](#)
- SetAmpNodeID
 - LSS, [397](#)
- SetAnalogCommandFilter
 - Amp, [106](#)
- SetAnalogRefConfig
 - Amp, [106](#)
- setAutoDelete
 - RefObj, [474](#)
- SetBaud
 - CanInterface, [177](#)
 - CopleyCAN, [198](#)
 - IxxatCAN, [361](#)
 - IxxatCANV3, [365](#)
 - KvaserCAN, [370](#)
- setBits
 - EventMap, [267](#)
- SetCammingConfig
 - Amp, [106](#)
- SetCanNetworkConfig
 - Amp, [107](#)
- setChain
 - Event, [257](#)
- SetControlWord
 - Amp, [107](#)
- SetCountsPerUnit
 - Amp, [107](#), [108](#)
- SetCrntLoopConfig
 - Amp, [108](#)
- SetCurrentProgrammed
 - Amp, [108](#)
- SetDAConverterConfig
 - Amp, [109](#)
- setData
 - EcatDgram, [235](#)
- SetDebugLevel
 - CopleyMotionLibrary, [215](#)
- SetDec
 - Path, [427](#)
- setDim
 - Point, [457](#)
 - PointN, [459](#)
- SetFaultMask
 - Amp, [109](#)
- SetFlushLog
 - CopleyMotionLibrary, [216](#)
- SetFuncGenConfig
 - Amp, [109](#)
- SetGainScheduling
 - Amp, [109](#)
- SetHaltMode
 - Amp, [111](#)
- SetHomeAccel
 - Amp, [111](#)
- SetHomeConfig
 - Amp, [111](#)
- SetHomeCurrent
 - Amp, [111](#)
- SetHomeDelay
 - Amp, [112](#)
- SetHomeMethod
 - Amp, [112](#)
- SetHomeOffset
 - Amp, [112](#)
- SetHomeVelFast
 - Amp, [113](#)
- SetHomeVelSlow
 - Amp, [113](#)
- SetID
 - PDO, [437](#)
- SetIOAnlg
 - CopleyIO, [206](#)
- SetIOConfig
 - CopleyIO, [206](#)
- SetIODigi

- CopleyIO, [206](#)
- SetIOInfo
 - CopleyIO, [206](#)
- SetIOOptions
 - Amp, [116](#)
- SetIOPWM
 - CopleyIO, [208](#)
- SetIloopCommandFilter
 - Amp, [113](#)
- SetIloopCommandFilter2
 - Amp, [113](#)
- SetInputConfig
 - Amp, [115](#)
- SetInputDebounce
 - Amp, [115](#)
- SetInputShapingFilter
 - Amp, [115](#)
- SetIoConfig
 - Amp, [116](#)
- SetIoPullup
 - Amp, [116](#)
- SetIoPullup32
 - Amp, [117](#)
- SetJrk
 - Path, [428](#)
- SetLogFile
 - CopleyMotionLibrary, [216](#)
- setMask
 - EventMap, [267](#)
- SetMaxLogSize
 - CopleyMotionLibrary, [216](#)
- SetMicrostepRate
 - Amp, [117](#)
- SetMoveLimits
 - Linkage, [380](#)
- SetMtrInfo
 - Amp, [117](#)
- SetName
 - CanInterface, [177](#)
- setNdx
 - EcatDgram, [235](#)
- SetNetworkOptions
 - Amp, [117](#)
- setNext
 - EcatDgram, [235](#)
- SetNodeGuard
 - CanOpen, [188](#)
 - EtherCAT, [248](#)
- SetNodeInfo
 - Network, [405](#)
- SetOutputConfig
 - Amp, [118](#)
- SetOutputs
 - Amp, [118](#)
- SetPhaseMode
 - Amp, [119](#)
- SetPosCaptureCfg
 - Amp, [119](#)
- SetPosLoopConfig
 - Amp, [121](#)
- SetPositionActual
 - Amp, [119](#)
- SetPositionErrorWindow
 - Amp, [120](#)
- SetPositionLoad
 - Amp, [120](#)
- SetPositionMotor
 - Amp, [120](#)
- SetPositionWarnWindow
 - Amp, [121](#)
- setPriority
 - Thread, [503](#)
- SetProfileAcc
 - Amp, [121](#)
- SetProfileConfig
 - Amp, [121](#)
- SetProfileDec
 - Amp, [122](#)
- SetProfileJerk
 - Amp, [122](#)
- SetProfileType
 - Amp, [122](#)
- SetProfileVel
 - Amp, [123](#)
- SetPvtInitialPos
 - Amp, [123](#)
- SetPwmInConfig
 - Amp, [123](#)
- SetPwmMode
 - Amp, [124](#)
- SetQuickStop
 - Amp, [124](#)
- SetQuickStopDec
 - Amp, [124](#)
- SetRefName
 - RefObj, [474](#)
- SetRegenConfig
 - Amp, [124](#)
- SetRtrOk
 - TPDO, [508](#)
- SetSettlingTime
 - Amp, [125](#)
- SetSettlingWindow
 - Amp, [125](#)
- SetSoftLimits
 - Amp, [125](#)
- SetStartPos
 - Path, [428](#)

- TrjScurve, [517](#)
- SetSync0Period
 - EtherCAT, [248](#)
- SetSynchId
 - Node, [418](#)
- SetSynchPeriod
 - Node, [418](#)
- SetSynchProducer
 - CanOpen, [188](#)
- SetTargetPos
 - Amp, [126](#)
- SetTargetVel
 - Amp, [126](#)
- SetTimeout
 - SDO, [492](#)
- setTimeout
 - LSS, [397](#)
- SetTorqueRated
 - Amp, [126](#)
- SetTorqueSlope
 - Amp, [127](#)
- SetTorqueTarget
 - Amp, [127](#)
- SetTraceChannel
 - Amp, [127](#)
- SetTracePeriod
 - Amp, [127](#)
- SetTraceTrigger
 - Amp, [128](#)
- SetTrackingWindows
 - Amp, [128](#)
- SetType
 - PDO, [437](#)
- SetUstepConfig
 - Amp, [129](#)
- setValue
 - Event, [257](#)
- SetVel
 - Path, [428](#)
- SetVelLoopConfig
 - Amp, [130](#)
- SetVelocityProgrammed
 - Amp, [130](#)
- SetVelocityWarnTime
 - Amp, [130](#)
- SetVelocityWarnWindow
 - Amp, [130](#)
- SetVloopCommandFilter
 - Amp, [131](#)
- SetVloopOutputFilter
 - Amp, [131](#)
- SetVloopOutputFilter2
 - Amp, [131](#)
- SetVloopOutputFilter3
 - Amp, [131](#)
- settlingTime
 - TrackingWindows, [509](#)
- settlingWin
 - TrackingWindows, [509](#)
- SetupMove
 - Amp, [128](#), [129](#)
- shift
 - VelLoopConfig, [521](#)
- sleep
 - Thread, [504](#)
- slope
 - CrntLoopConfig, [222](#)
- SoftPosLimit, [500](#)
 - accel, [501](#)
 - macroEncoderCapture, [501](#)
 - motorPosWrap, [501](#)
 - neg, [501](#)
 - pos, [501](#)
- start
 - Thread, [504](#)
- StartHeartbeat
 - Node, [418](#)
- StartMove
 - Amp, [133](#)
 - Linkage, [380](#)
- StartNew
 - LinkTrajectory, [388](#)
 - LinkTrjScurve, [391](#)
 - Path, [429](#)
 - Trajectory, [512](#)
 - TrjScurve, [517](#)
- StartNode
 - CanOpen, [188](#)
 - Node, [419](#)
- StartNodeGuard
 - Node, [419](#)
- StartPVT
 - Amp, [133](#)
- stepHoldCurrent
 - CrntLoopConfig, [222](#)
- stepRate
 - AmpConfig, [145](#)
- stepRun2HoldTime
 - CrntLoopConfig, [223](#)
- stepVolControlDelayTime
 - CrntLoopConfig, [223](#)
- stop
 - Thread, [504](#)
- StopGuarding
 - Node, [419](#)
- StopNode
 - CanOpen, [188](#)
 - Node, [419](#)

SupportsTimestamps
 CanInterface, 177
 CopleyCAN, 199
 syncID
 CanOpenSettings, 195
 synchID
 AmpSettings, 161
 synchPeriod
 AmpSettings, 161
 synchProducer
 AmpSettings, 161
 SynchStart
 Node, 419
 SynchStop
 Node, 420
 synchUseFirstAmp
 AmpSettings, 161

 TRACETRIG_ABOVE
 CML_AmpDef.h, 554
 TRACETRIG_BELOW
 CML_AmpDef.h, 554
 TRACETRIG_BITCLR
 CML_AmpDef.h, 554
 TRACETRIG_BITSET
 CML_AmpDef.h, 554
 TRACETRIG_CHANGE
 CML_AmpDef.h, 554
 TRACETRIG_CHANNEL
 CML_AmpDef.h, 554
 TRACETRIG_EVENTCLR
 CML_AmpDef.h, 554
 TRACETRIG_EVENTSET
 CML_AmpDef.h, 554
 TRACETRIG_FALL
 CML_AmpDef.h, 554
 TRACETRIG_FGEN_CYCLE
 CML_AmpDef.h, 554
 TRACETRIG_NODELAY
 CML_AmpDef.h, 554
 TRACETRIG_NONE
 CML_AmpDef.h, 554
 TRACETRIG_RISE
 CML_AmpDef.h, 554
 TRACETRIG_SAMPLE
 CML_AmpDef.h, 554
 TRACETRIG_TYPE
 CML_AmpDef.h, 554
 TRACEVAR_ANALOG_REF
 CML_AmpDef.h, 555
 TRACEVAR_CMD_ACC
 CML_AmpDef.h, 555
 TRACEVAR_CMD_POS
 CML_AmpDef.h, 555
 TRACEVAR_CMD_VEL
 CML_AmpDef.h, 555
 TRACEVAR_CRNT_A
 CML_AmpDef.h, 555
 TRACEVAR_CRNT_ACT_D
 CML_AmpDef.h, 555
 TRACEVAR_CRNT_ACT_Q
 CML_AmpDef.h, 555
 TRACEVAR_CRNT_B
 CML_AmpDef.h, 555
 TRACEVAR_CRNT_CMD
 CML_AmpDef.h, 555
 TRACEVAR_CRNT_CMD_D
 CML_AmpDef.h, 555
 TRACEVAR_CRNT_CMD_Q
 CML_AmpDef.h, 555
 TRACEVAR_CRNT_ERR_D
 CML_AmpDef.h, 555
 TRACEVAR_CRNT_ERR_Q
 CML_AmpDef.h, 555
 TRACEVAR_CRNT_LIM
 CML_AmpDef.h, 555
 TRACEVAR_DEST_POS
 CML_AmpDef.h, 555
 TRACEVAR_ENC_COS
 CML_AmpDef.h, 555
 TRACEVAR_ENC_SIN
 CML_AmpDef.h, 555
 TRACEVAR_EVENTLATCH
 CML_AmpDef.h, 555
 TRACEVAR_EVENTS
 CML_AmpDef.h, 555
 TRACEVAR_HALLS
 CML_AmpDef.h, 555
 TRACEVAR_HIGH_VOLT
 CML_AmpDef.h, 555
 TRACEVAR_INPUTS
 CML_AmpDef.h, 555
 TRACEVAR_LOAD_POS
 CML_AmpDef.h, 555
 TRACEVAR_MTR_POS
 CML_AmpDef.h, 555
 TRACEVAR_PHASE
 CML_AmpDef.h, 555
 TRACEVAR_POS_ERR
 CML_AmpDef.h, 555
 TRACEVAR_RAW_INPUTS
 CML_AmpDef.h, 555
 TRACEVAR_TEMP
 CML_AmpDef.h, 555
 TRACEVAR_VEL_LOAD
 CML_AmpDef.h, 555
 TRACEVAR_VEL_MTR
 CML_AmpDef.h, 555

- TRACEVAR_VEL_RAW
 - CML_AmpDef.h, 555
- TRACEVAR_VLOOP_CMD
 - CML_AmpDef.h, 555
- TRACEVAR_VLOOP_ERR
 - CML_AmpDef.h, 555
- TRACEVAR_VLOOP_LIM
 - CML_AmpDef.h, 555
- TRACEVAR_VOLT_D
 - CML_AmpDef.h, 555
- TRACEVAR_VOLT_Q
 - CML_AmpDef.h, 555
- TPDO, 506
 - ProcessData, 508
 - Received, 508
 - SetRtrOk, 508
- Thread, 502
 - getTimeMS, 503
 - run, 503
 - setPriority, 503
 - sleep, 504
 - start, 504
 - stop, 504
 - Thread, 503
- ThreadError, 505
- Threads.cpp, 626
- timeID
 - CanOpenSettings, 196
- timeStampID
 - AmpSettings, 161
- ToAmpFormat
 - CanNetworkConfig, 180
- toString
 - Error, 241
- TpdoDisable
 - Node, 420
- TraceStart
 - Amp, 133
- TraceStop
 - Amp, 133
- trackErr
 - TrackingWindows, 509
- trackWarn
 - TrackingWindows, 509
- TrackingWindows, 508
 - settlingTime, 509
 - settlingWin, 509
 - trackErr, 509
 - trackWarn, 509
 - TrackingWindows, 509
 - TrackingWindows, 509
- Trajectory, 510
 - Finish, 511
 - MaximumBufferPointsToUse, 511
 - NextSegment, 512
 - StartNew, 512
 - UseVelocityInfo, 512
- Transmit
 - IOModule::AlgOutPDO, 28
 - IOModule::DigOutPDO, 231
 - RPDO_LinkCtrl, 482
- TrjError, 513
 - NoneAvailable, 514
- TrjScurve, 514
 - Calculate, 516
 - GetStartPos, 517
 - SetStartPos, 517
 - StartNew, 517
 - TrjScurve, 516
 - TrjScurve, 516
- uint16
 - CML_Utils.h, 615
- uint32
 - CML_Utils.h, 615
- UnInit
 - Node, 420
- Unlock
 - Mutex, 402
- Update
 - IOModule::AlgOutPDO, 28
 - IOModule::DigOutPDO, 231
- UpdateBit
 - IOModule::DigOutPDO, 231
- UpdateEvents
 - Amp, 133
- Upld16
 - Amp, 135
 - SDO, 492, 493
- Upld32
 - Amp, 135, 136
 - SDO, 493
- Upld8
 - Amp, 136
 - SDO, 493, 494
- UpldFit
 - SDO, 494
- UpldString
 - Amp, 137
 - SDO, 494
- Upload
 - Amp, 137
 - SDO, 495
- useAsTimingReference
 - CanOpenSettings, 196
- useStandardAinPDO
 - IOModuleSettings, 356
- useStandardAoutPDO

- IOModuleSettings, [356](#)
- useStandardDinPDO
 - IOModuleSettings, [356](#)
- useStandardDoutPDO
 - IOModuleSettings, [356](#)
- useSwitch
 - CanNetworkConfig, [181](#)
- UseVelocityInfo
 - LinkTrajectory, [388](#)
 - Trajectory, [512](#)
- UstepConfig, [518](#)
 - maxVelAdj, [518](#)
 - UstepConfig, [518](#)
 - ustepConfigAndStatus, [518](#)
 - ustepPGainOutLoop, [519](#)
 - UstepConfig, [518](#)
- ustepConfigAndStatus
 - UstepConfig, [518](#)
- ustepPGainOutLoop
 - UstepConfig, [519](#)
- uunit
 - CML_Utils.h, [615](#)
- uvCfg
 - PwmInConfig, [467](#)
- vOff
 - RegenConfig, [477](#)
- vOn
 - RegenConfig, [477](#)
- vel
 - ProfileConfigScurve, [462](#)
 - ProfileConfigTrap, [463](#)
 - ProfileConfigVel, [464](#)
- velCmdff
 - VelLoopConfig, [521](#)
- velFast
 - HomeConfig, [280](#)
- VelLoad2User
 - Amp, [137](#)
- VelLoopConfig, [519](#)
 - estopDec, [520](#)
 - maxAcc, [520](#)
 - maxDec, [520](#)
 - maxVel, [520](#)
 - shift, [521](#)
 - velCmdff, [521](#)
 - VelLoopConfig, [520](#)
 - VelLoopConfig, [520](#)
- VelMtr2User
 - Amp, [138](#)
- velSlow
 - HomeConfig, [280](#)
- VelUser2Load
 - Amp, [138](#)
- VelUser2Mtr
 - Amp, [138](#)
- Wait
 - Event, [257](#)
- WaitCycleUpdate
 - EtherCAT, [249](#)
- WaitEvent
 - Amp, [139](#)
 - Linkage, [380](#), [381](#)
- WaitHomeDone
 - Amp, [139](#)
- WaitIOEvent
 - IOModule, [353](#), [354](#)
- WaitInputEvent
 - Amp, [139](#)
- WaitInputHigh
 - Amp, [140](#)
- WaitInputLow
 - Amp, [140](#)
- WaitMoveDone
 - Amp, [141](#)
 - Linkage, [381](#)
- Warn
 - CopleyMotionLibrary, [216](#)
- WinUdpEcatHardware, [521](#)
 - WinUdpEcatHardware, [522](#)
 - WinUdpEcatHardware, [522](#)
- Write
 - Pmap16, [444](#)
 - Pmap24, [447](#)
 - Pmap32, [449](#)
 - Pmap8, [453](#)
- Xmit
 - CanInterface, [178](#)
 - CanOpen, [189](#)
 - LSS, [397](#)
- XmitFrame
 - CanInterface, [178](#)
 - CopleyCAN, [199](#)
 - IxxatCAN, [361](#)
 - IxxatCANV3, [365](#)
 - KvaserCAN, [370](#)
- XmitPDO
 - CanOpen, [189](#)
- XmitSDO
 - CanOpen, [189](#)